

Notes.
 All details existing, unless marked proposed
 Original drawing size A4
 Scaled dimensions should not be taken from this
 drawing unless authorised.
 Licence number 100048623

Insite Poster Properties Ltd
 Barton Hall
 29 Gloucester Street
 Cirencester
 Gloucestershire, GL7 2DJ
 Tel. 01285 658666 www.insite.co.uk

INSITE Ref: _____
 8270

Project _____
 Land at
 258 - 274 Grays Inn Road
 London
 WC1X 8LH

Drawing Name _____
 Elevations - Existing
 and Proposed

Drawing Status _____
 PLANNING

Revision _____
 - First Formal Issue KK

Date _____
 22 November 2018

Drawing Scale @ A4 _____
 1:100

Layout ID _____ **Revision** _____
 T4085 A4 060

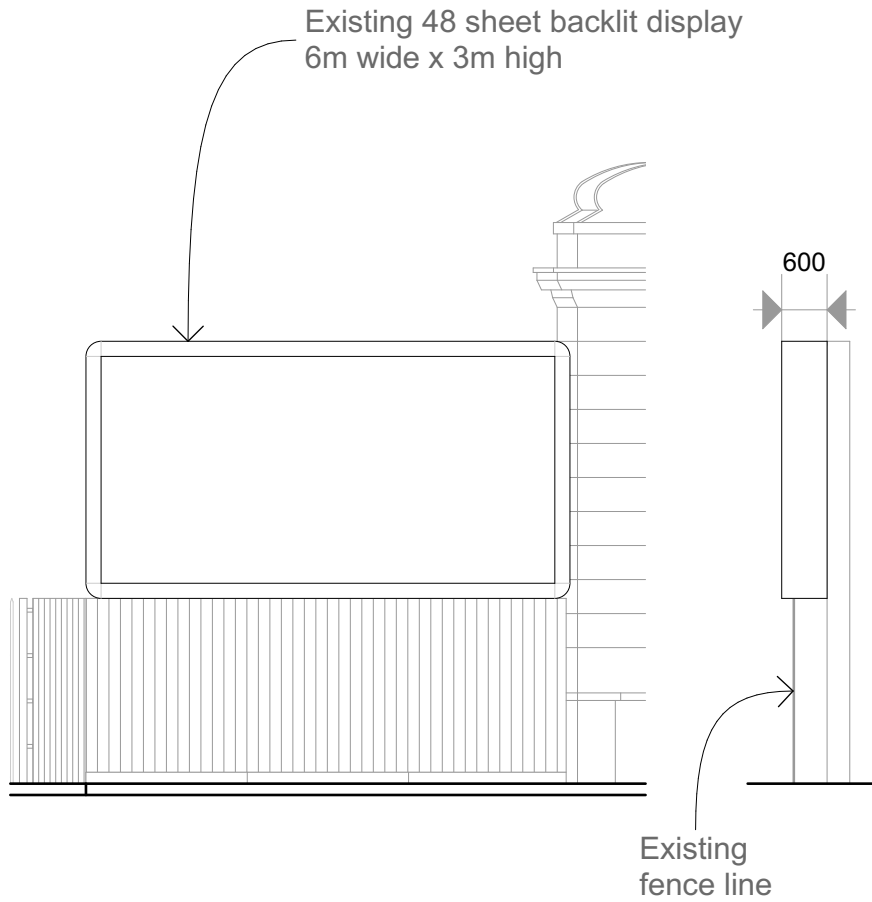

Existing
 West Elevation

Section

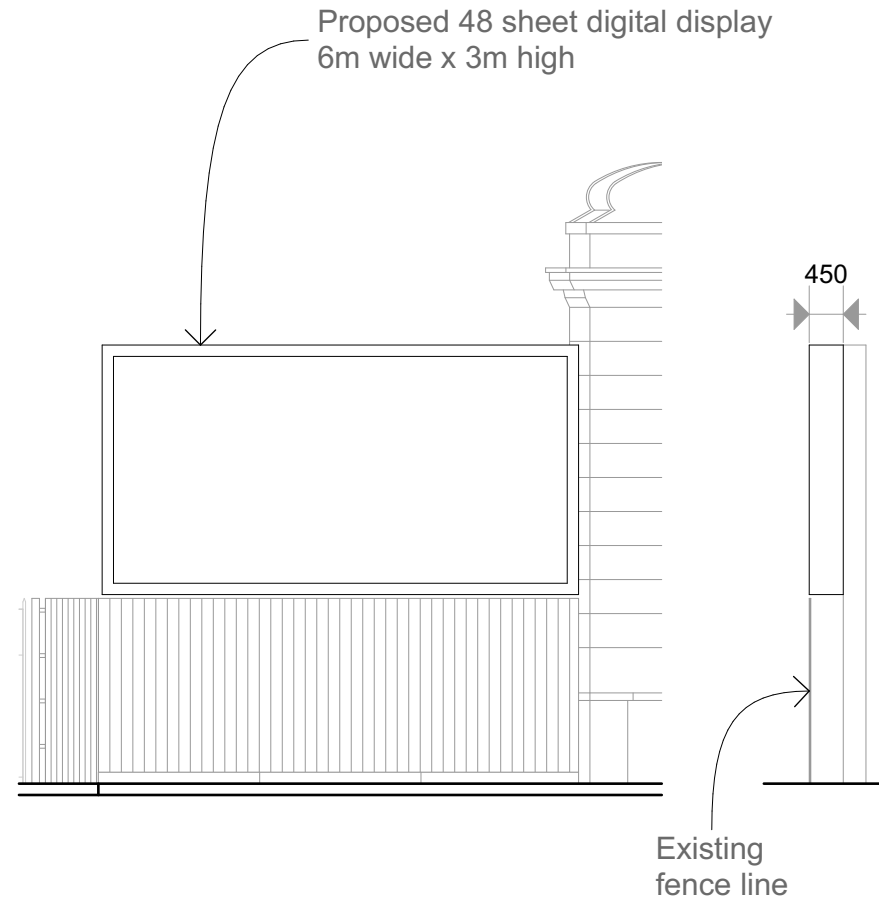

Proposed
 West Elevation

Section

