

D-25 - TYPICAL WINDOW CUFF HEAD DETAIL
SCALE: 1:10@A3

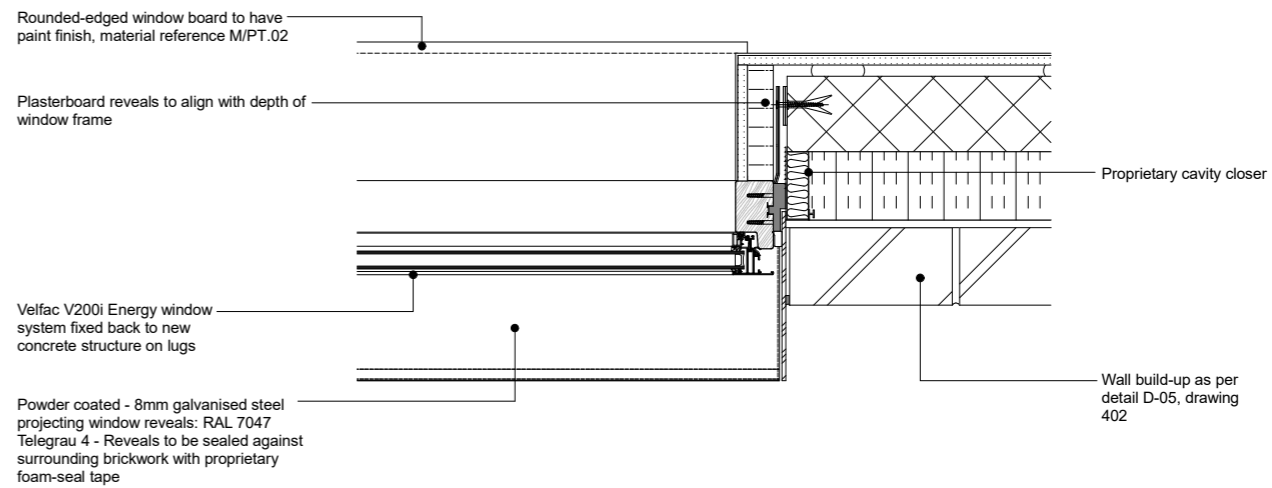

D-27 - TYPICAL WINDOW CUFF PLAN DETAIL
SCALE: 1:10@A3

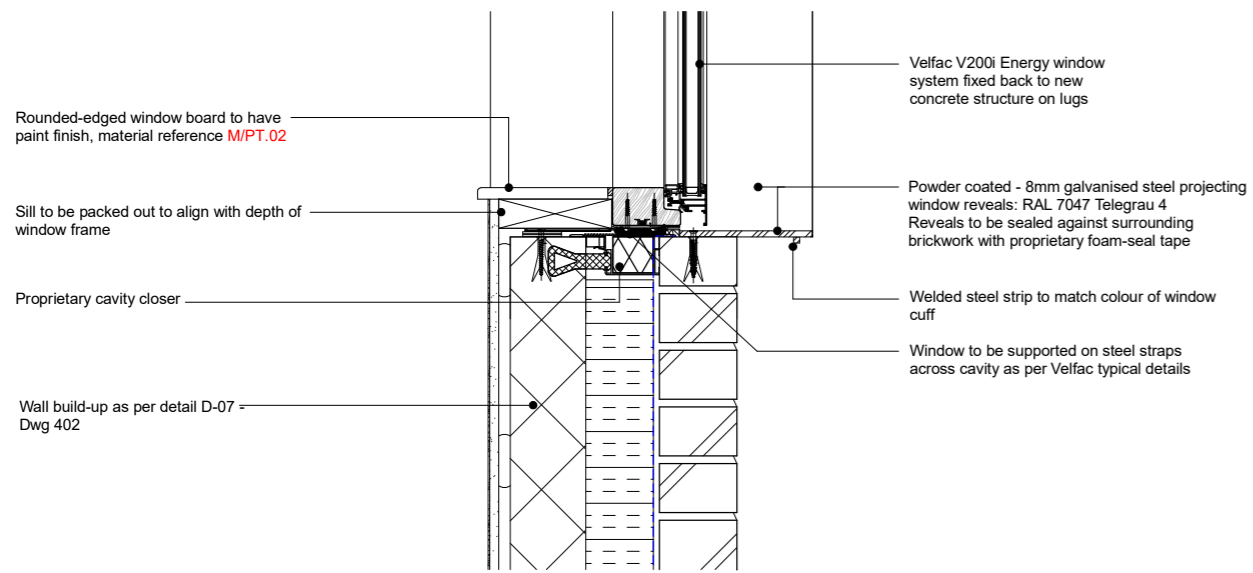

D-26 - TYPICAL WINDOW CUFF SILL DETAIL
SCALE: 1:10@A3

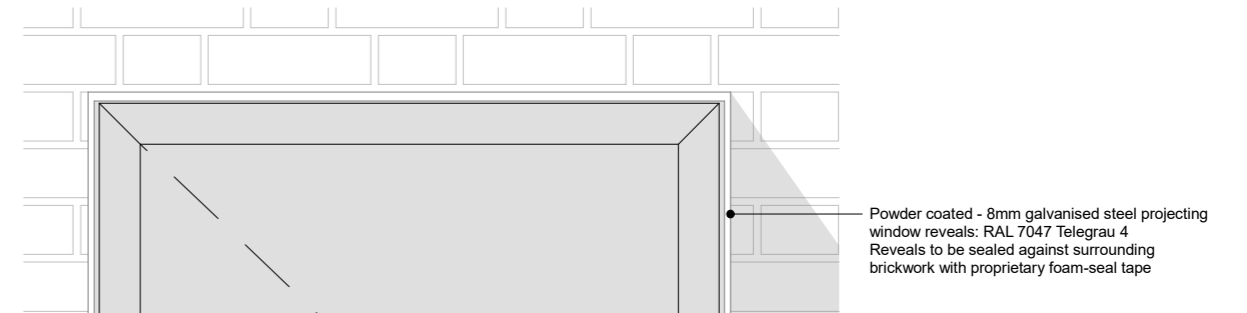

TYPICAL WINDOW HEAD ELEVATION
SCALE 1:10 @A3

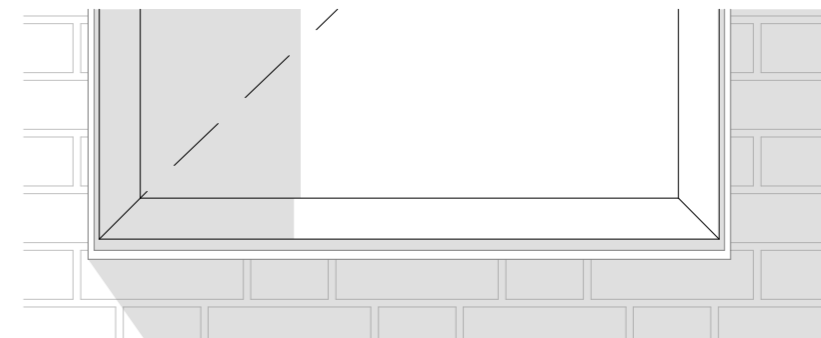

TYPICAL WINDOW SILL ELEVATION
SCALE 1:10 @A3

WINDOWS: WD-02-05, WD-03-05

Rev:	Date:	Description:	By:	Chkd:

Rev:	Date:	Description:	By:	Chkd:

The copyright of this drawing and design remains the intellectual property of the designers and may not be used without the written permission of alma-nac Ltd. Do not Scale. Verify all dimensions on site before commencing work or preparing shop drawings. Report any discrepancies, errors or omissions to the designers and await further instructions before the commencement of works. All building materials, components and workmanship to comply with the appropriate public health acts, building regulations, British standards, codes of practice and the appropriate manufacturer's recommendations. Ensure all works are carried out within the prescribed hours of work and that all tools are of a non-percussive type where possible. Refer to the relevant drawings or method statement for all specialist work.

Project: PILGRIMS LANE, London, NW3 1SS	
Project Number: 215	Date: 02/11/2018
Scale: 1:10 @A3	Drawn By: AS
	Checked By: TW

Drawing Number: 407	Drawing Status: TENDER	Revision: 01
Title: TYPICAL VELFAC-V200i WINDOW DETAILS - EXTERNAL CUFF		
11 Waterloo Court, 10 Theed Street, London SE1 8ST +44 (0)20 7928 2092 / info@alma-nac.com		