

PROPOSED ARE TIMBER WINDOWS LIKE FOR LIKE SLIMLITE DOUBLE GLAZED TO MATCH EXISTING

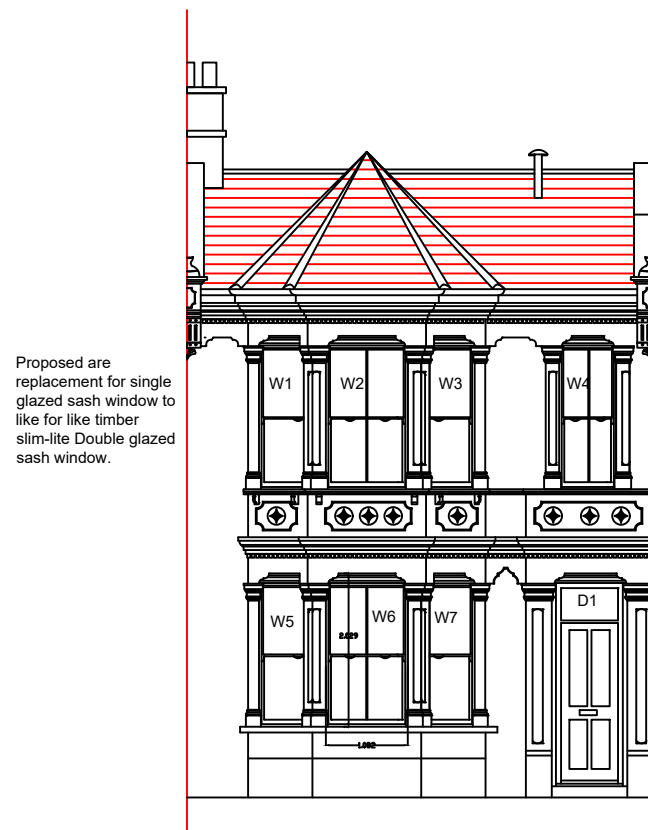

FRONT ELEVATION  
(Proposed)

Proposed are replacement for single glazed sash window to like for like timber slim-lite Double glazed sash window.

PROPOSALS:  
The proposals are for replacement of the existing timber windows at the front, rear and side of the property.  
The proposed windows are timber like for like double glazed Slim-lite units to current building regulations as per attached details.  
The fenestration will be followed to the front, side and rear elevation.

PROPOSED ARE TIMBER WINDOWS LIKE FOR LIKE SLIMLITE DOUBLE GLAZED TO MATCH EXISTING)



REAR ELEVATION  
(Proposed)

Proposed are replacement for single glazed sash window to like for like timber slim-lite Double glazed sash window.

PROPOSALS:  
The proposals are for replacement of the existing timber windows at the front, rear and side of the property.  
The proposed windows are timber like for like double glazed Slim-lite units to current building regulations as per attached details.  
The fenestration will be followed to the front, side and rear elevation.

PROPOSED ARE TIMBER WINDOWS LIKE FOR LIKE SLIMLITE DOUBLE GLAZED TO MATCH EXISTING

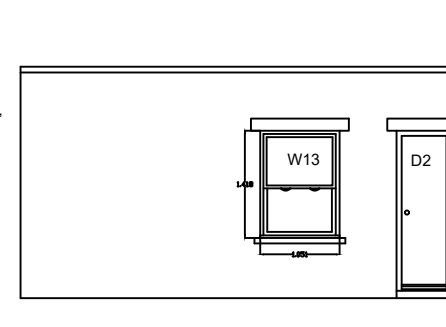

SIDE ELEVATION  
(Proposed)

Proposed are replacement for single glazed sash window to like for like timber slim-lite Double glazed sash window.

10 Meter

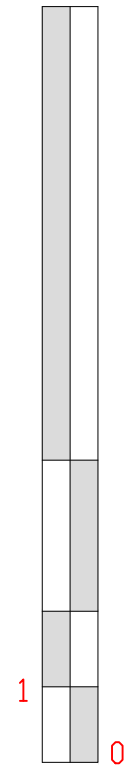

1:100



EMPLOYER'S AGENTS & PROJECT MANAGERS  
UNIT A COURT HOUSE, 11A HIGH STREET  
BARNET EN5 5UJ  
TEL: 020 8446 5537  
E-MAIL: [Planning@walkercc.co.uk](mailto:Planning@walkercc.co.uk)

TITLE  
PROPOSED ELEVATIONS

PROJECT  
122 Maygrove Road

CLIENT  
GENESIS HOUSING ASSOCIATION / KIER

SCALE: AS IDENTIFIED  
CAD FILE: -  
DATE: 30.08.18  
DRAWN BY: RBM  
CHECKED:

PROJECT NO.	DRAWING NO.	REVISION
999	999/WM/02	0