

Do not scale from this drawing

The contractor shall check and verify all dimensions on site and report any discrepancies in writing to CH+MRP Architects (CH+MRP) before proceeding with work

Existing buildings shown are based on measured surveys received from third parties. Any discrepancies should be made in writing to CH+MRP to be resolved by the original surveyors.

This drawing is the copyright of CH+MRP and cannot be reproduced without prior written permission from the architects

Existing: timber framed single glazed sash window
Proposed: timber framed double glazed sash window

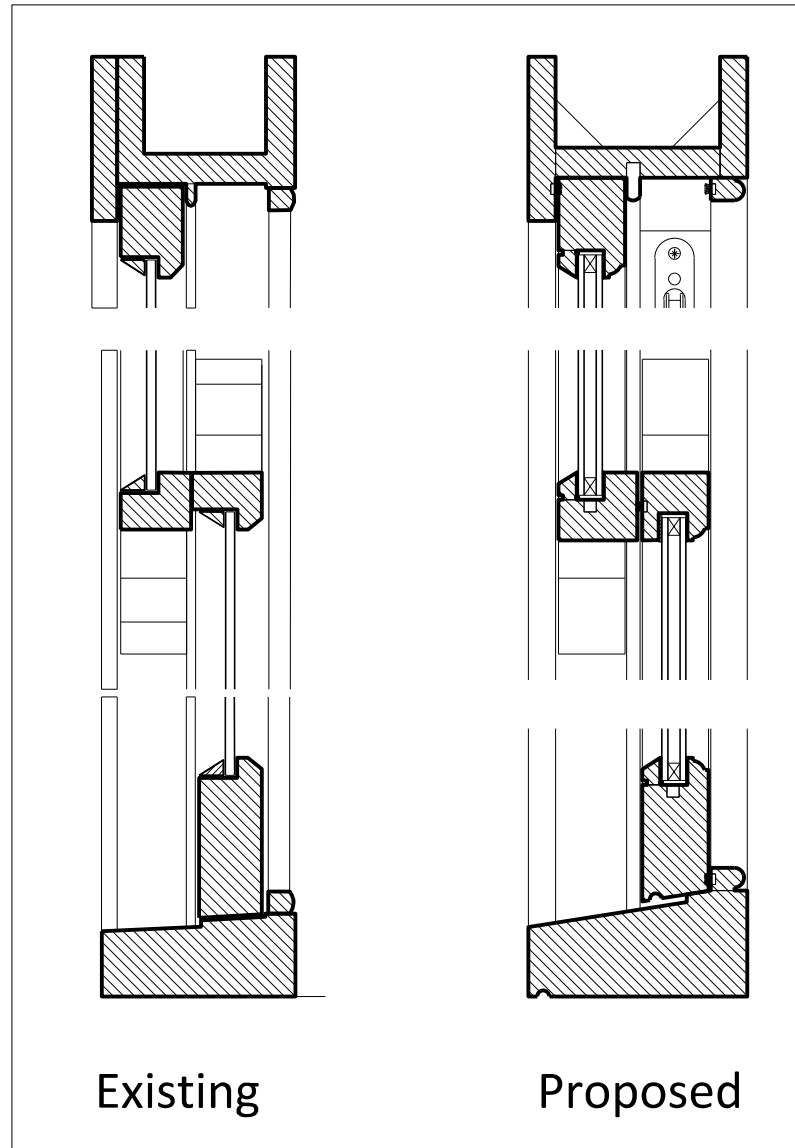

SECTION

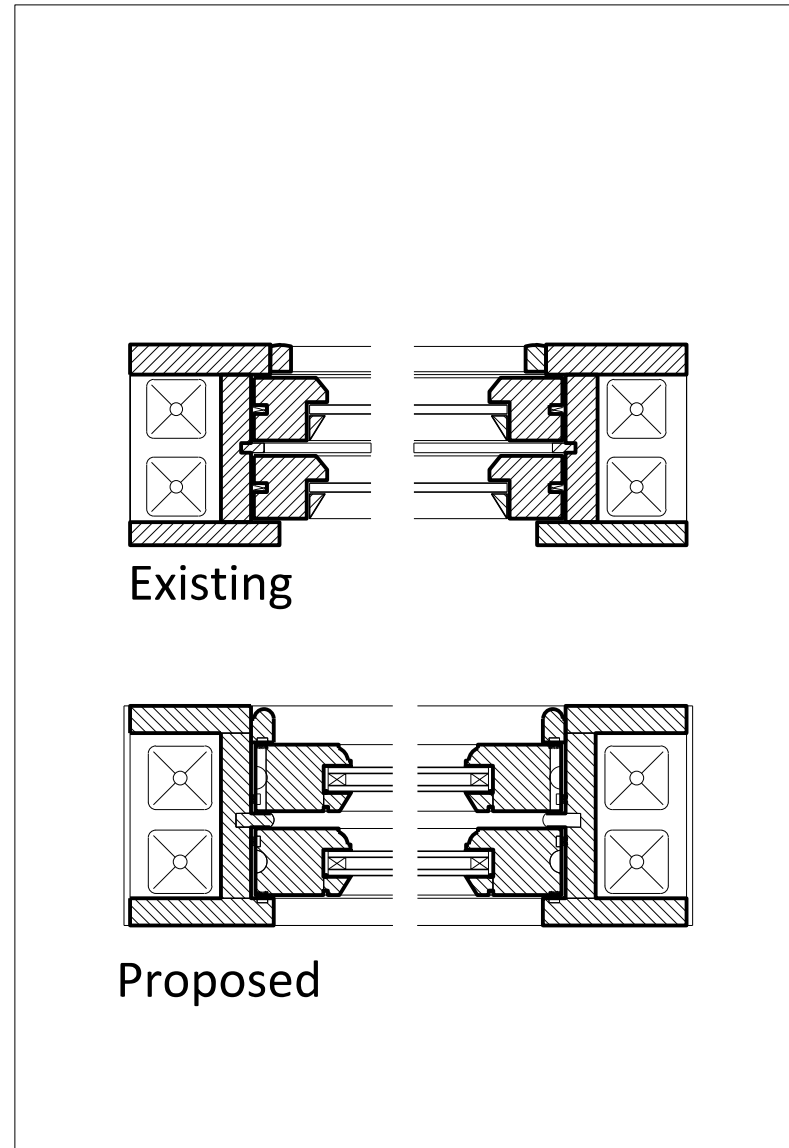

PLAN

Rev. A 31/10/18 Issued to Planning

CH+MRP
ARCHITECTS

41-42 FOLEY STREET
LONDON
W1W 7TS

T: +44 (0)20 7253 2526
eM: mail@ch-architects.com

Project
9 PRIMROSE GARDENS

Status
PLANNING

Drawing
TYPICAL WINDOW DETAILS

Drwg No :
377_31_600

Scale :
1:5@A3

Date :
30/10/18