

Overview of the whole Section 1
Scale 1:300

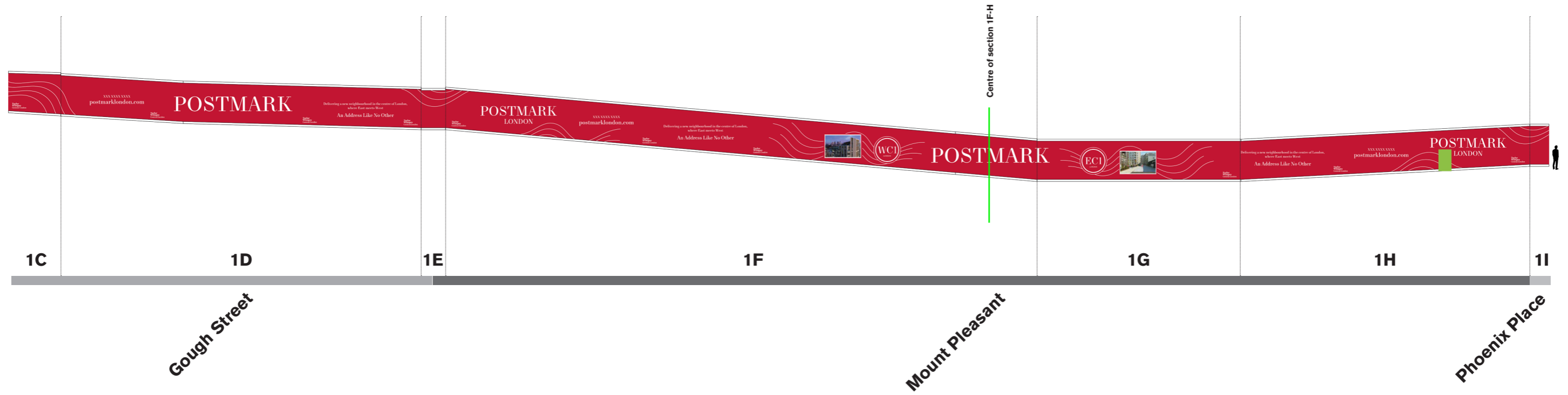

Detail of Section 1 C, 1D and 1E
Scale: 1:100

Section 1C (3.5° Decline)
3.86 x 3.06 m (into 3.18)m

Section 1D (3.5° Decline-first 9.00m, 1.5° Decline-remainder) -
26,50 x 3.13m

Section 1E
1.78 x 3.05 m

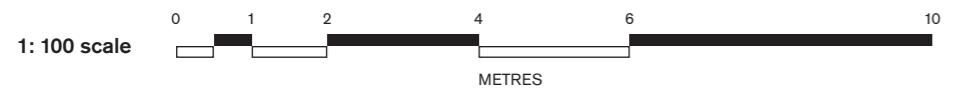
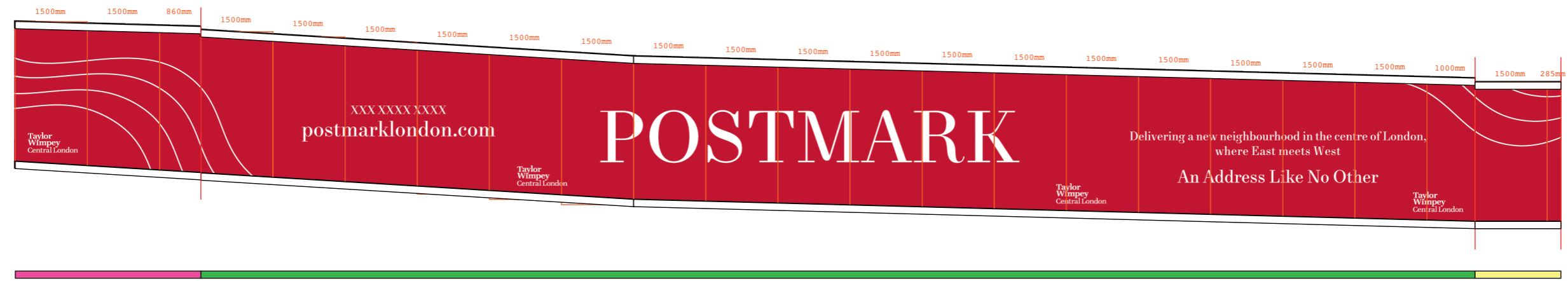

Detail of Section 1F and 1G
Scale: 1:100

Section 1F (5° Decline)
43.00 x 3.14 m

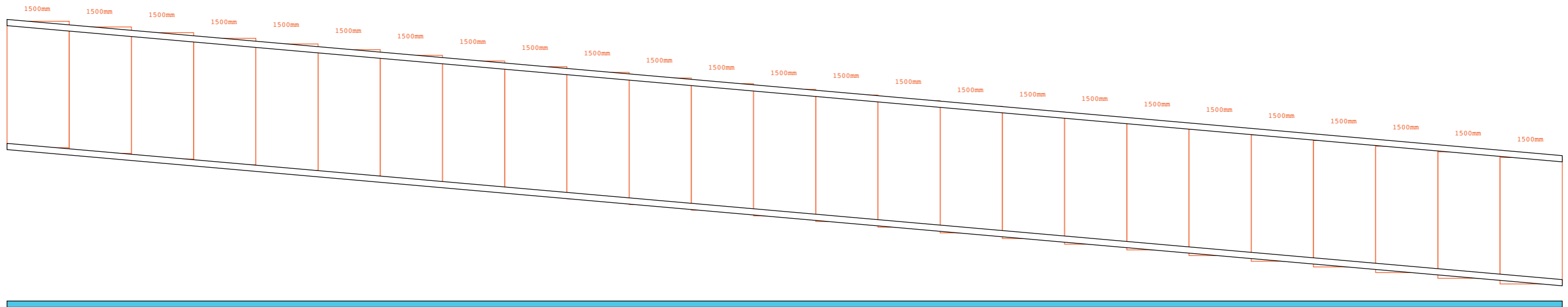

Section 1G
15.00 x 3.14 m

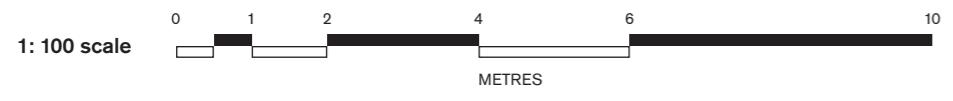
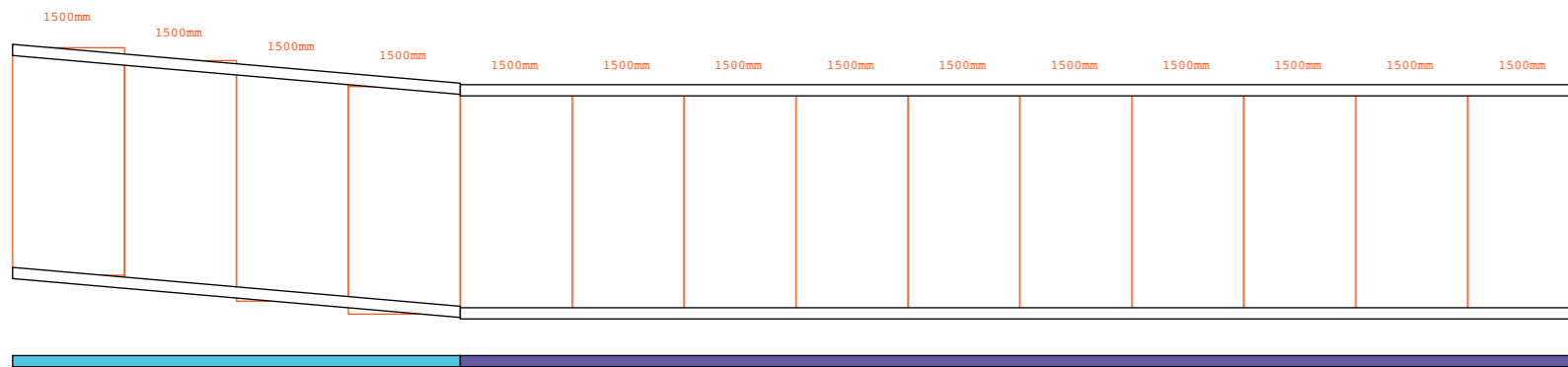

Detail of Section 1F and 1G
Scale: 1:100

Section 1F (5° Decline)
43.00 x 3.14 m



Section 1G
15.00 x 3.14 m

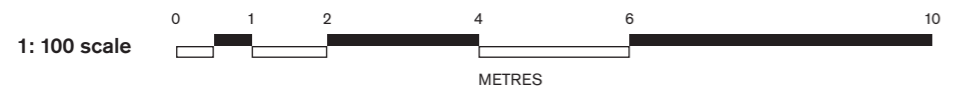
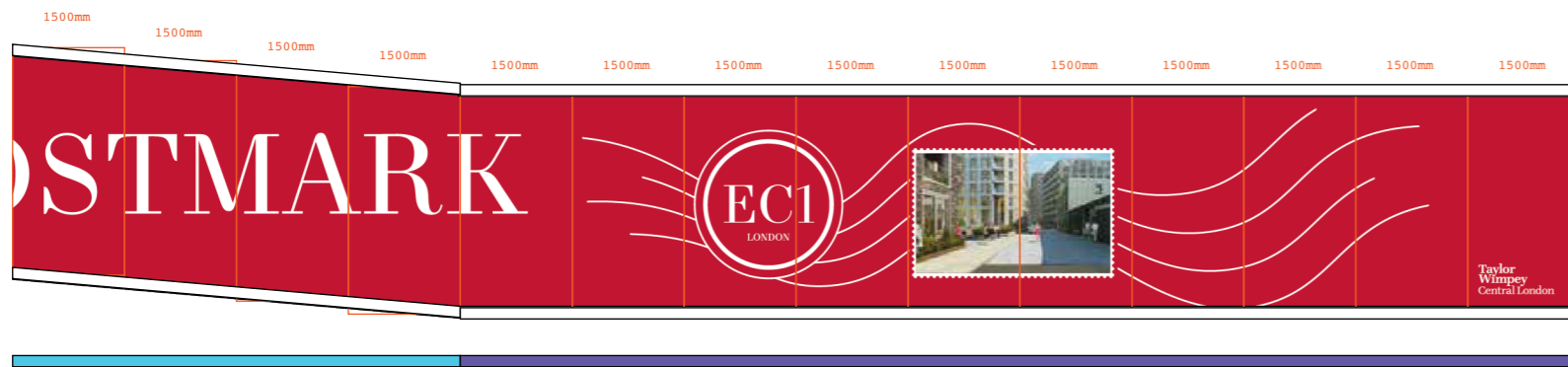

Detail of Section 1H, 1I and 1J
Scale: 1:100

Section 1H (3° incline)
21.24 x 3.11 m

Section 1I
1.42 x 3.06 m

Section 1J
5.97 x 1.80 m

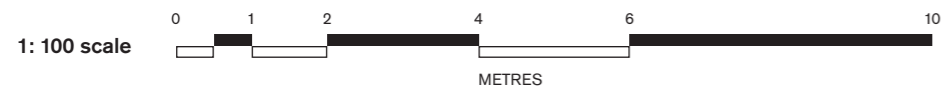
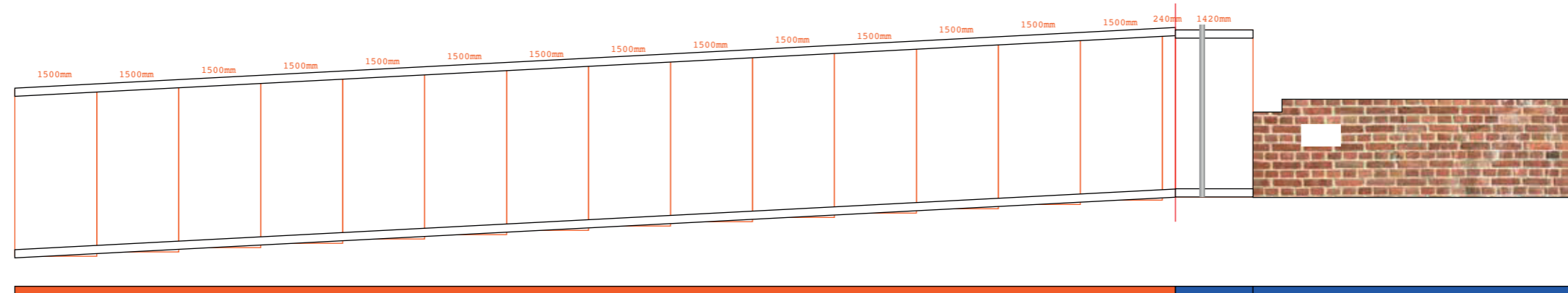

Detail of Section 1H, 1I and 1J
Scale: 1:100

Section 1H (3° incline)
21.24 x 3.11 m

Section 1I
1.42 x 3.06 m

Section 1J
5.97 x 1.80 m

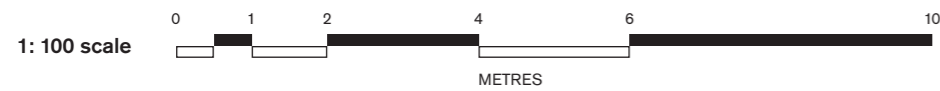
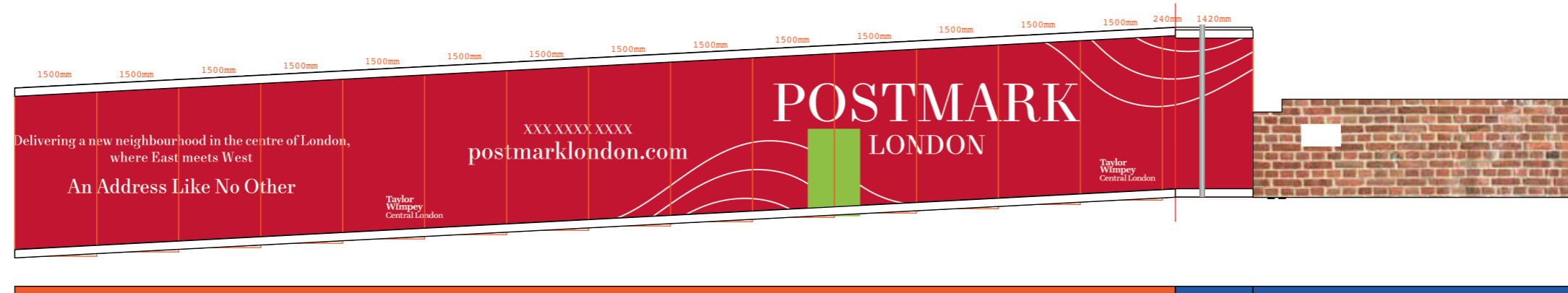

Key Dimensions

- Maximum height of lettering/symbol: **2.00m**
- Maximum projection from the face of the hoarding: **3mm**
- Height from the ground to the base of the advertisement: **0.016m**
- Height and length of the proposed advertisements: **Whole Section 1 = 112.8 x ~3.11m**

