

A

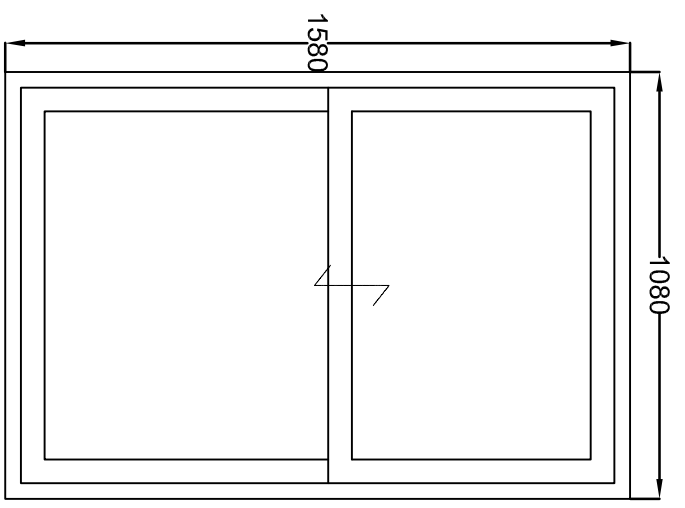

B

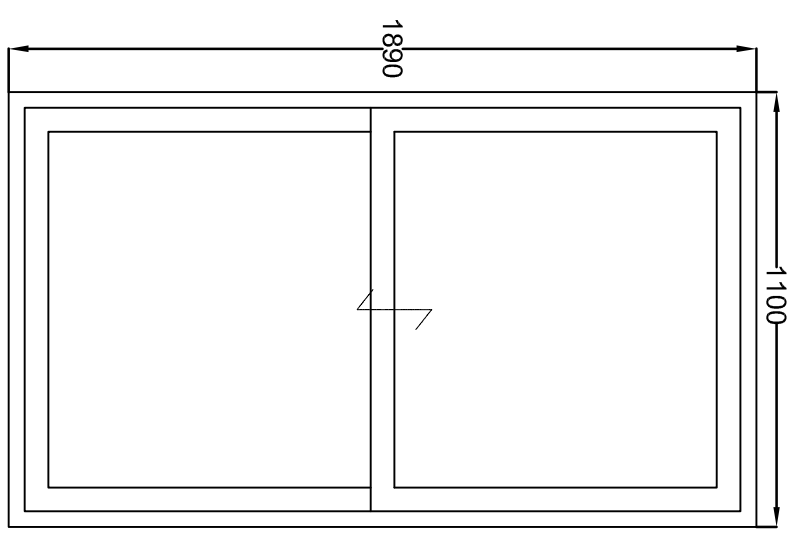

C

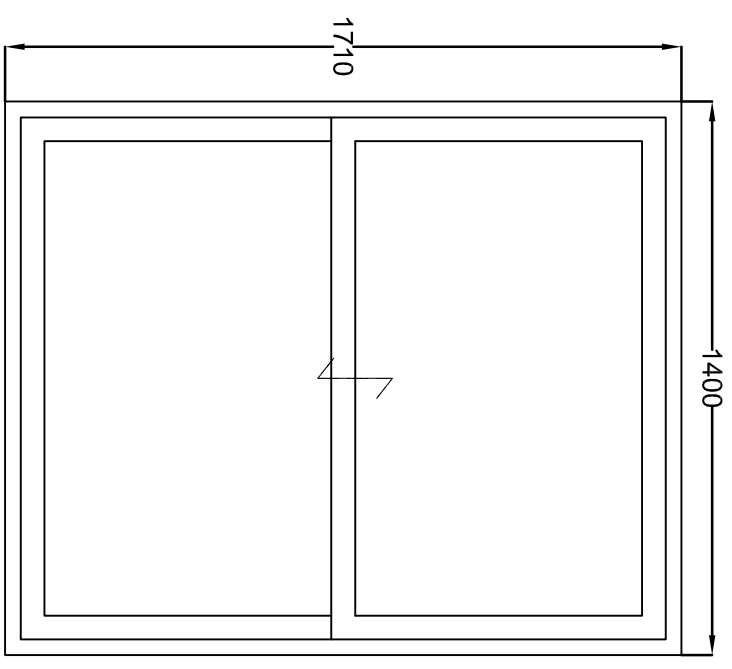

The contractor is responsible to ensure that no products are to be utilised that do not comply with relevant British and/or European Standards and/or Codes of Practice, COSHH regulations, Construction Regulations, or which are known or suspected at the time of product selection to be defective or otherwise unsuitable for the intended use of the work or not in accordance with good building practice.

The contractor is responsible for checking dimensions, tolerances, levels and references. This drawing is to be read in conjunction with all relevant contracts or specifications drawings. Any drawings are the property of Baily Garner LLP and require their consent for use on site or shop drawings.

Where an item is covered by drawings to different scales, the larger scale drawing is to be worked to.

Do not scale drawings. Figured dimensions to be worked to in all cases.

This drawing and the copyright and patent therein are the property of Baily Garner LLP and may not be used or reproduced without consent or attribution.

A3

REVISION	D	C	DATE



146-148 ELTHAM HILL
LONDON SE9 5DY
T. 020 3294 1000
F. 020 3294 1320
e. general@bailygarner.co.uk

CLIENT:
Clarion Housing Group

ADDRESS:
**50 Stanhope Street
London
NW1 3EX**

PROJECT:
Proposed Front Elevation

TITLE:
Window Replacement

PURPOSE OF ISSUE:
Planning

SCALE	D	C	DATE
1:20 @A3	CL		19/10/2018
JOB NO. 30668	DETAIL NO. P01	REVISION	