

No.	Revision	Date

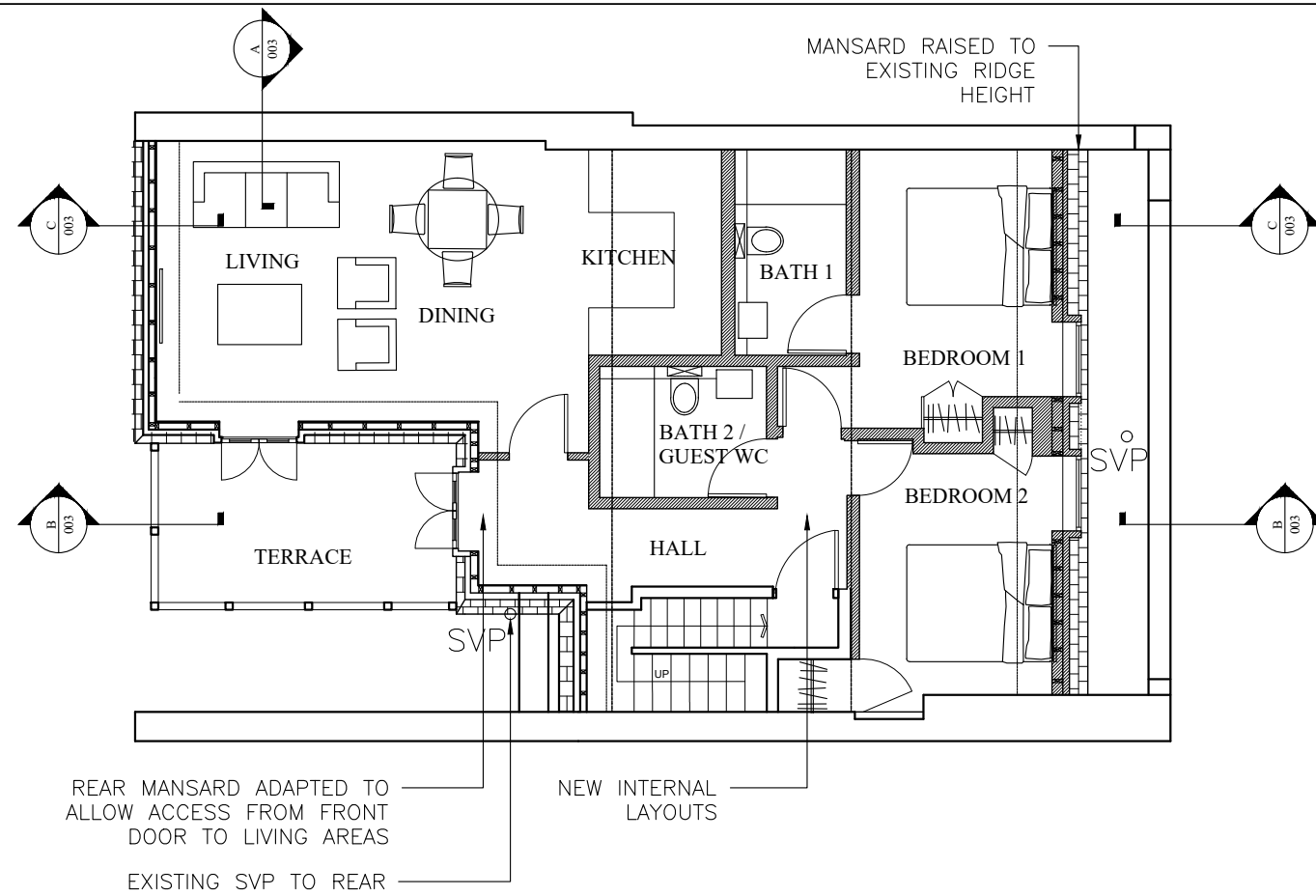

1 PROPOSED THIRD FLOOR PLAN
Scale: 1:100

2 PROPOSED ROOF PLAN
Scale: 1:100

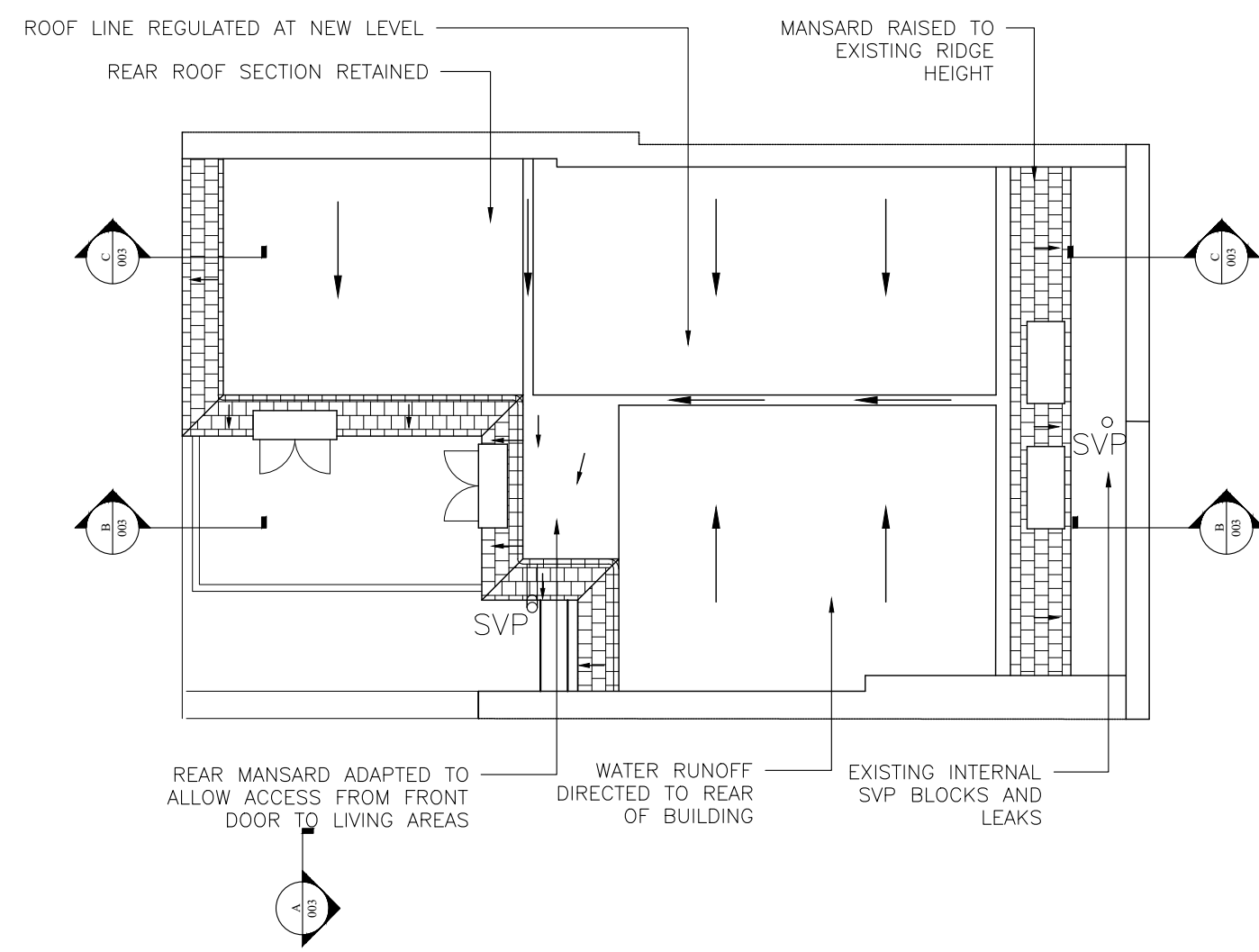

ISSUE 1

JL Project
277 GRAYS INN ROAD
JL Drawing Title
PROPOSED THIRD FLOOR PLAN & ROOF PLAN

Scale	Date	Dwn
1:100@A3	11/07/2018	NH
Drawing No.	Rev.	
813_011		
CAD Ref.	813	

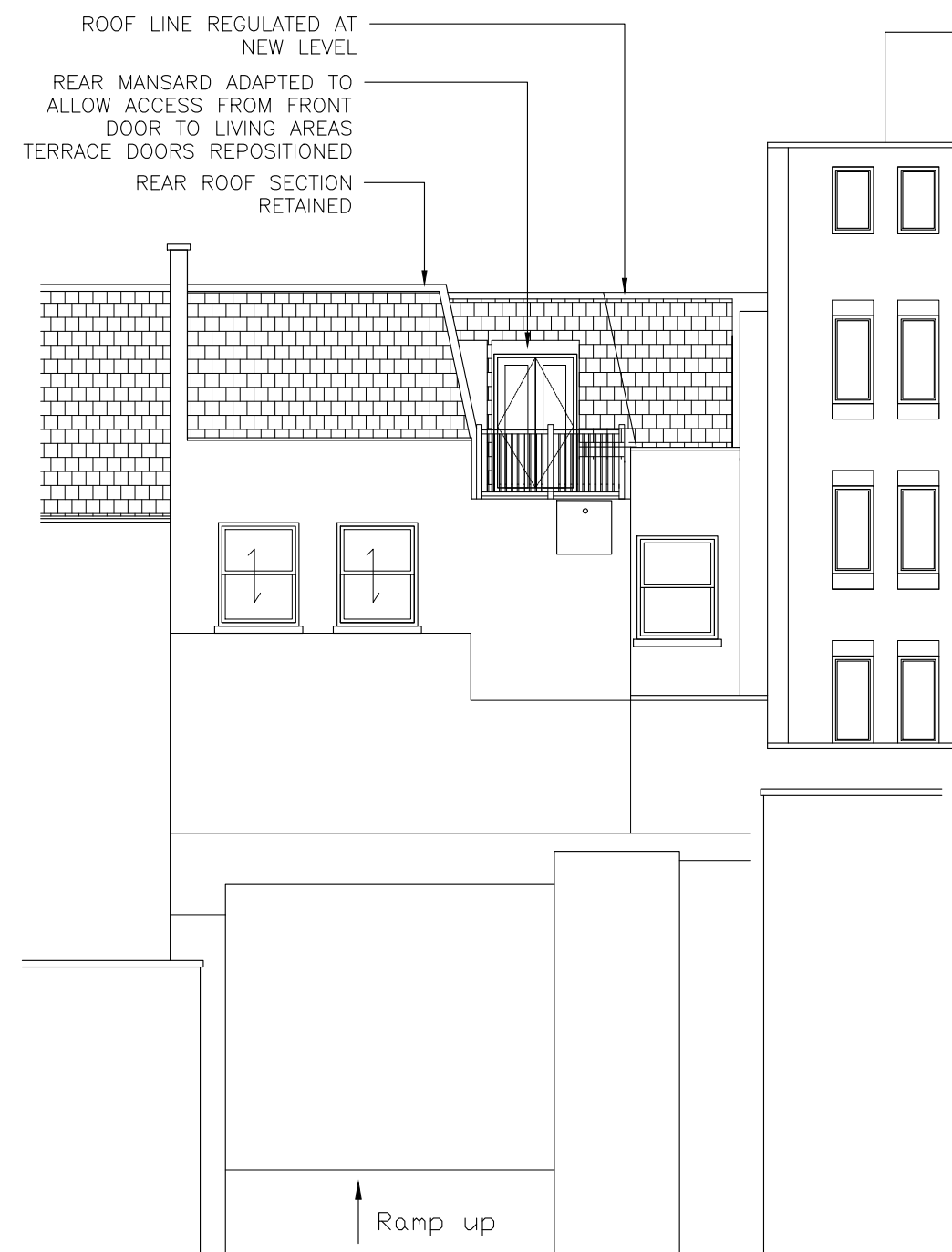

1 PROPOSED FRONT ELEVATION
Scale: 1:100

2 PROPOSED REAR ELEVATION
Scale: 1:100

ISSUE 1

JL Project
277 GRAYS INN ROAD
JL Drawing Title
PROPOSED FRONT & REAR
ELEVATIONS

Scale	Date	Dwn
1:100@A3	11/07/2018	NH
Drawing No.	Rev.	
813_012		
CAD Ref.	813	

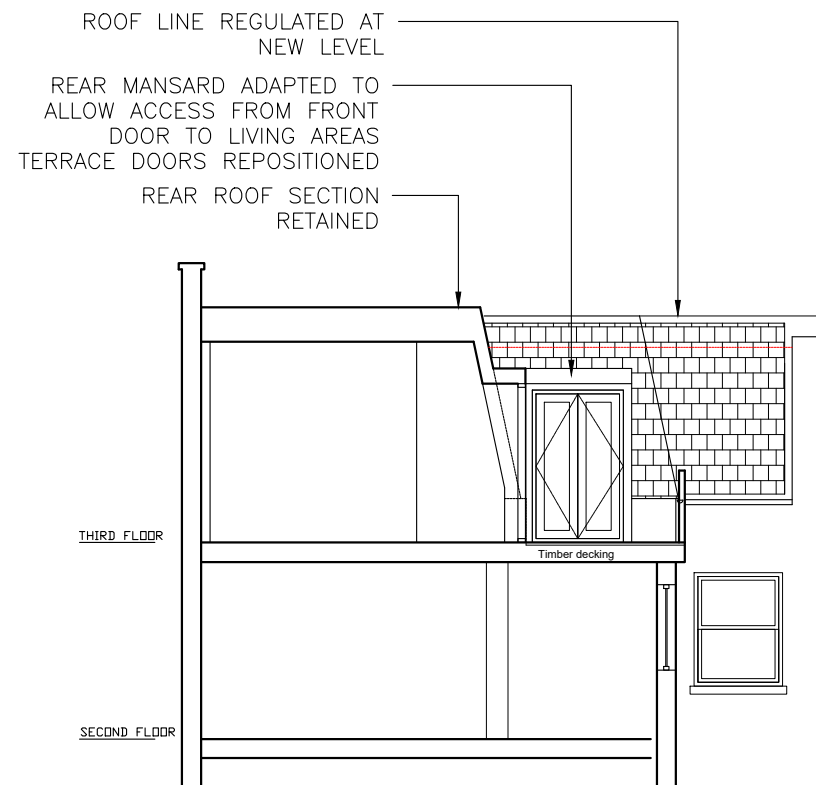

1 PROPOSED SECTION AA
Scale: 1:100

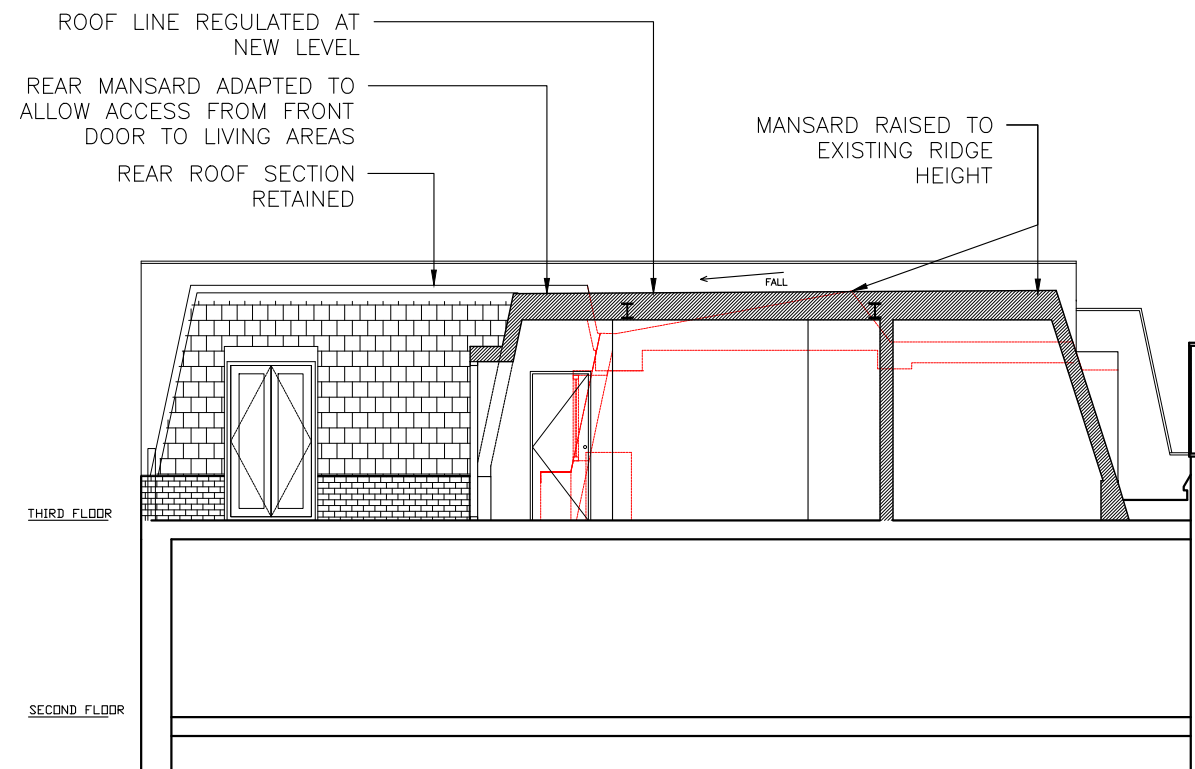

2 PROPOSED SECTION BB
Scale: 1:100

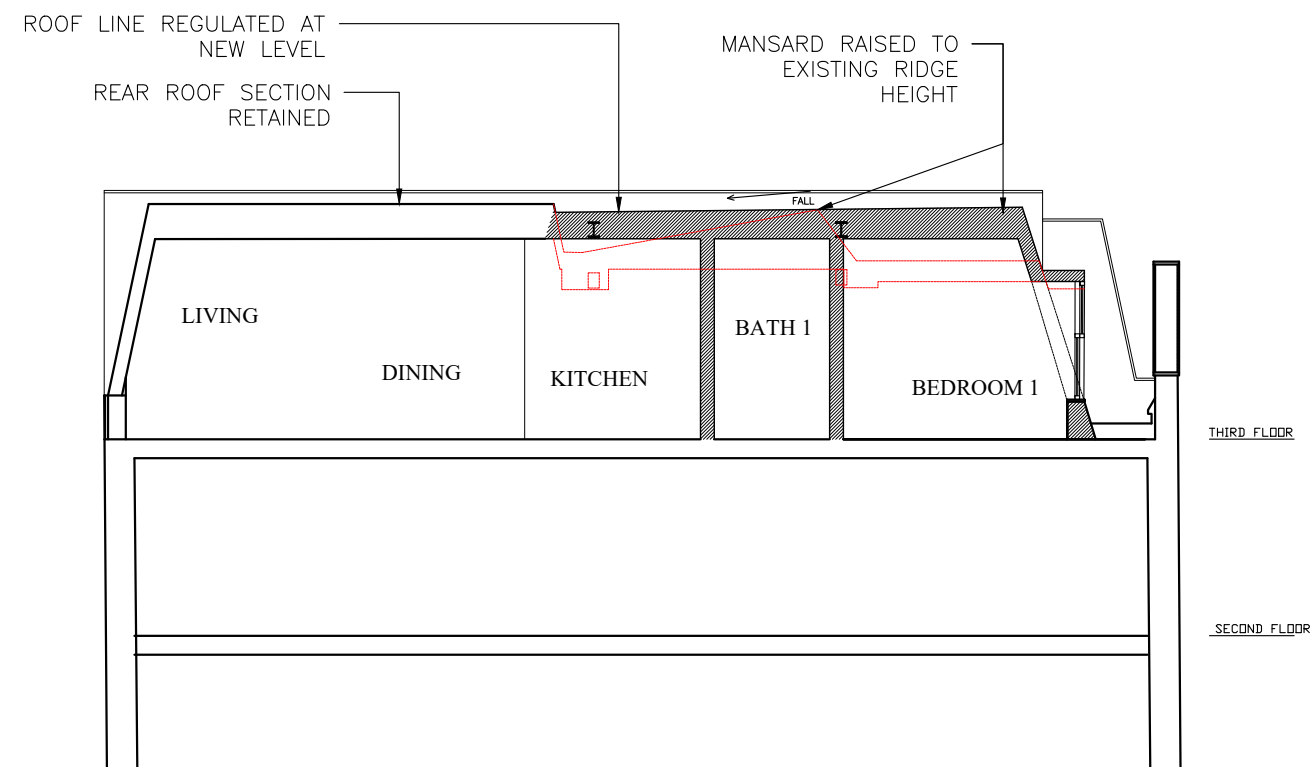

3 PROPOSED SECTION CC
Scale: 1:100

ISSUE 1

JL Project
277 GRAYS INN ROAD

JL Drawing Title
PROPOSED SECTIONS AA, BB
& CC

Scale	Date	Dwn
1:100@A3	11/07/2018	NH
Drawing No.	Rev.	
813_013		
CAD Ref.	813	

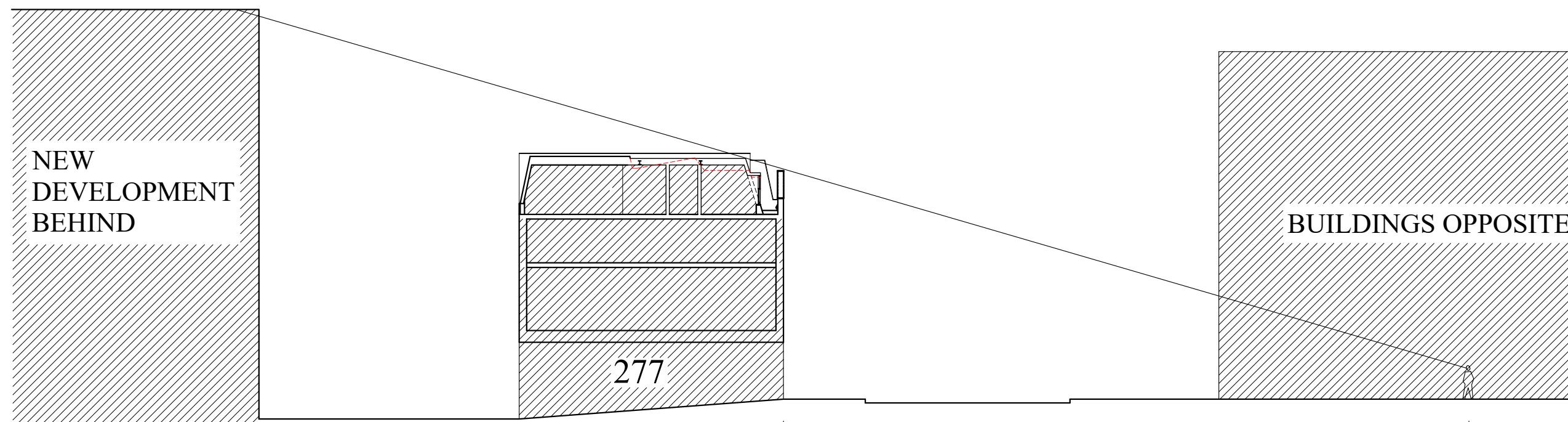

1 LINE OF SIGHT SECTION
Scale: 1:250

36m / 118ft

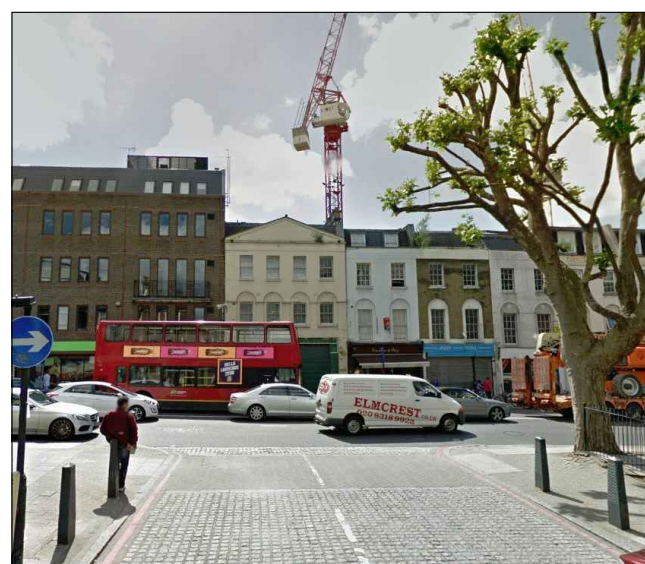

2 2008 VIEW FROM BRITANNIA ST
NTS

THIS IMAGE SHOWS THE VIEW OF THE BUILDING IN 2008 FROM THE POSITION SHOWN IN THE ABOVE DIAGRAM. THE VISIBLE ROOF LINE IS THE RIDGE LINE BEHIND THE MANSARD ROOF LINE. SEE DETAIL 1 & 2 813-015 FOR EXPLANATION

SEE DRAWING 813-016 DETAIL 1 FOR ELEVATION



3 2018 VIEW FROM BRITANNIA ST
NTS

THIS IMAGE SHOWS THE VIEW OF THE BUILDING IN 2018 FROM THE POSITION SHOWN IN THE ABOVE DIAGRAM. THE VISIBLE ROOF LINE IS THE RIDGE LINE BEHIND THE MANSARD ROOF LINE. THE NEW DEVELOPMENT CAN BE SEEN JUST ABOVE THE RIDGE LINE. SEE DRAWING 813-016 DETAIL 2 FOR ELEVATION



4 2018 VIEW FROM BRITANNIA ST
NTS

THIS IMAGE SHOWS THE VIEW OF THE BUILDING IN 2018 FROM MUCH FURTHER BACK UP BRITANNIA ST. THE VISIBLE ROOF LINE IS THE RIDGE LINE BEHIND THE MANSARD ROOF LINE. THE NEW DEVELOPMENT CAN BE SEEN TOWERING OVER THE BUILDING AS WELL AS A LOWER BRICK PARAPET OF THE NEW DEVELOPEMENT. SEE DRAWING 813-016 DETAIL 2 FOR ELEVATION

ISSUE 1

JL Project
277 GRAYS INN ROAD

JL Drawing Title
ELEVATIONS
BEFORE AND AFTER
DEVELOPMENT AT REAR

Scale	1:100@A3	Date	11/07/2018	Dwn	NH
Drawing No.	813_014	Rev.			
CAD Ref.	813				

No.	Revision	Date

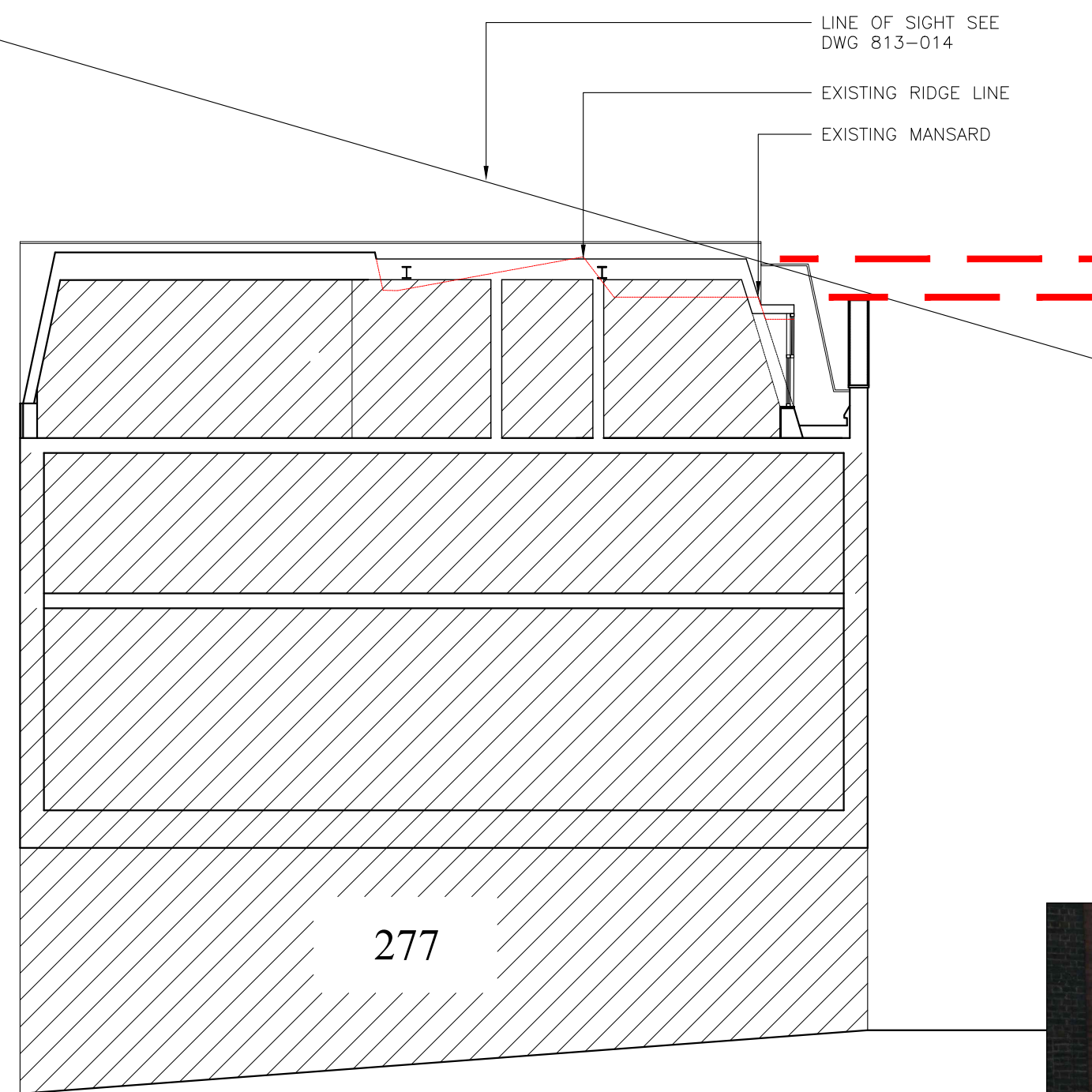

1 SECTION SHOWING EXISTING AND PROPOSED ROOF LINES
Scale: 1:100

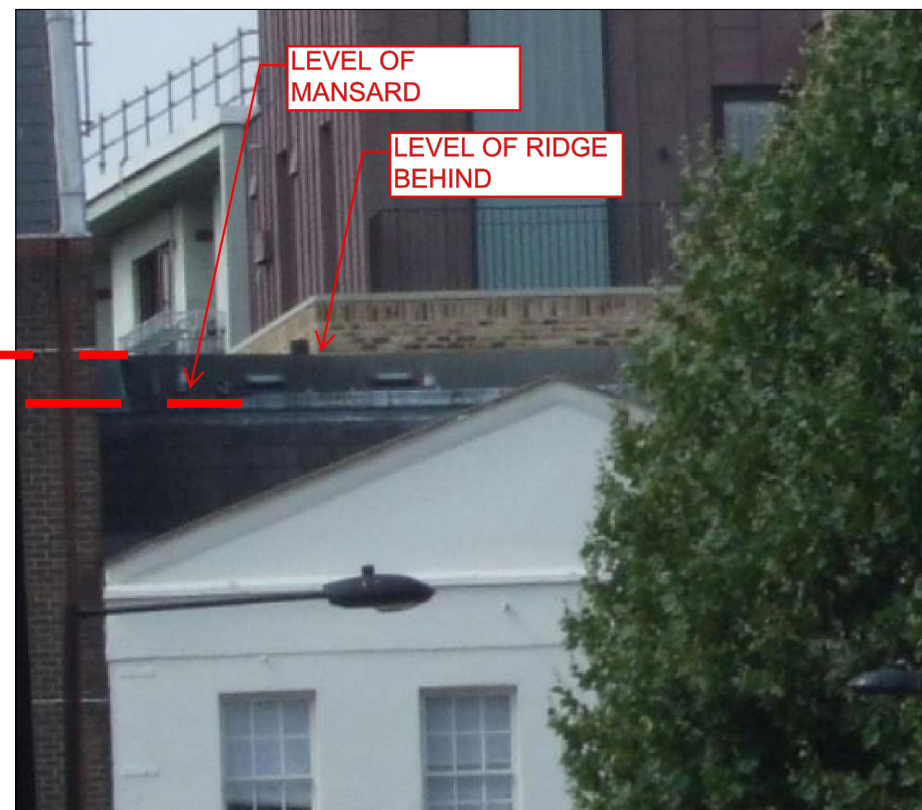

2 DETAIL OF FRONT ELEVATION
NTS



3 FULL PHOTO OF DEAIL 2
NTS

ISSUE 1

JL Project
277 GRAYS INN ROAD

JL Drawing Title
STREET VIEW AND SECTION TO SHOW ROOFLINE

Scale	Date	Dwn
1:100@A3	11/07/2018	NH
Drawing No.	Rev.	
813_015		
CAD Ref.	813	

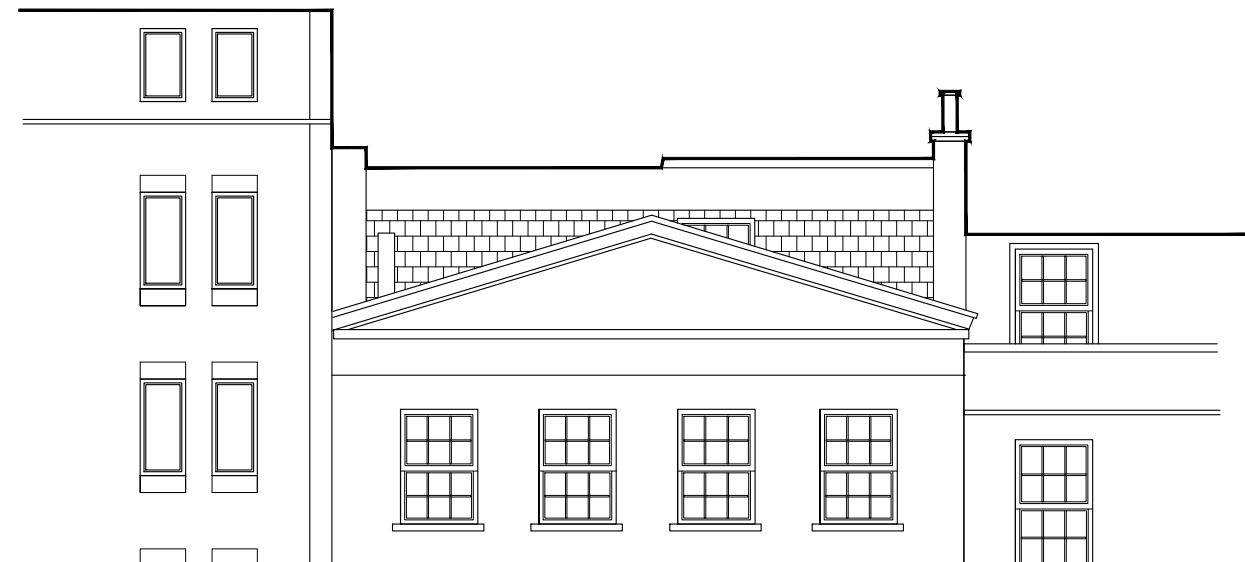

THIS IS THE ELEVATION
AS APPROVED IN
APPEAL
APP/X5210/A/08/2083216
BEFORE THE HAND AXE
YARD DEVELOPMENT
WAS CONSTRUCTED
BEHIND

1 APPROVED ELEVATION PRE DEVELOPMENT
Scale: 1:100

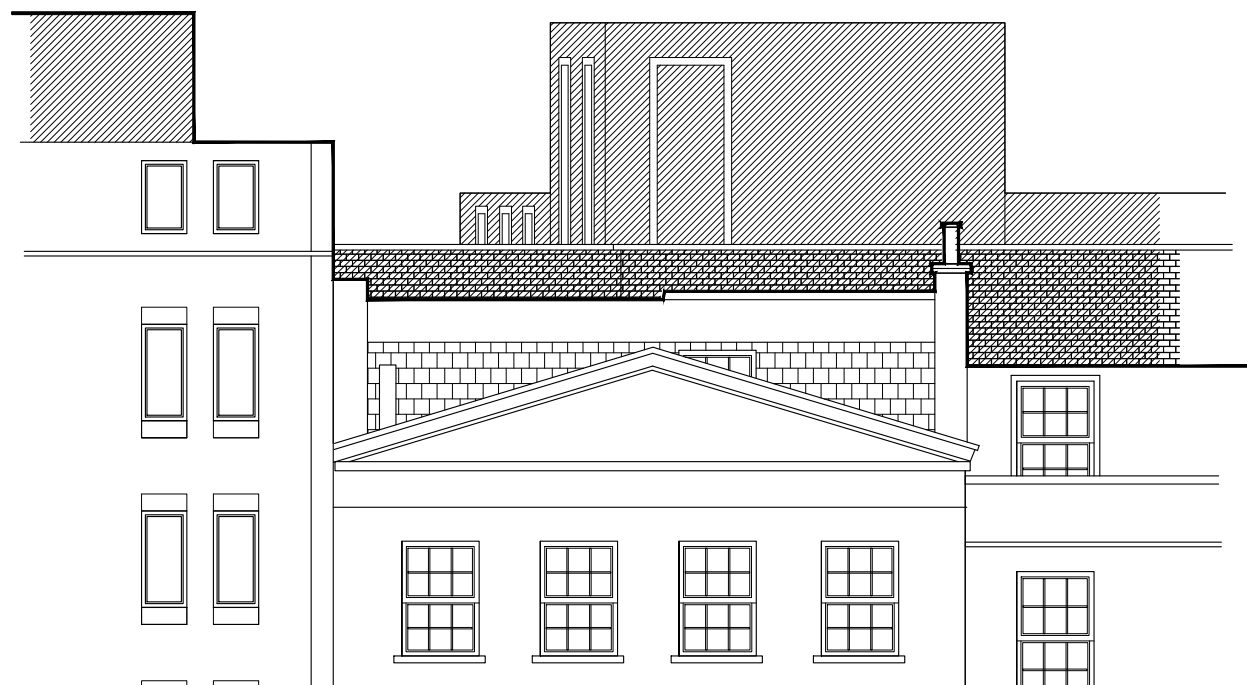

THIS IS THE CURRENT
ELEVATION AS
APPROVED IN APPEAL
APP/X5210/A/08/2083216
AFTER THE HAND AXE
YARD DEVELOPMENT
WAS CONSTRUCTED
BEHIND

2 APPROVED ELEVATION POST DEVELOPMENT
Scale: 1:100

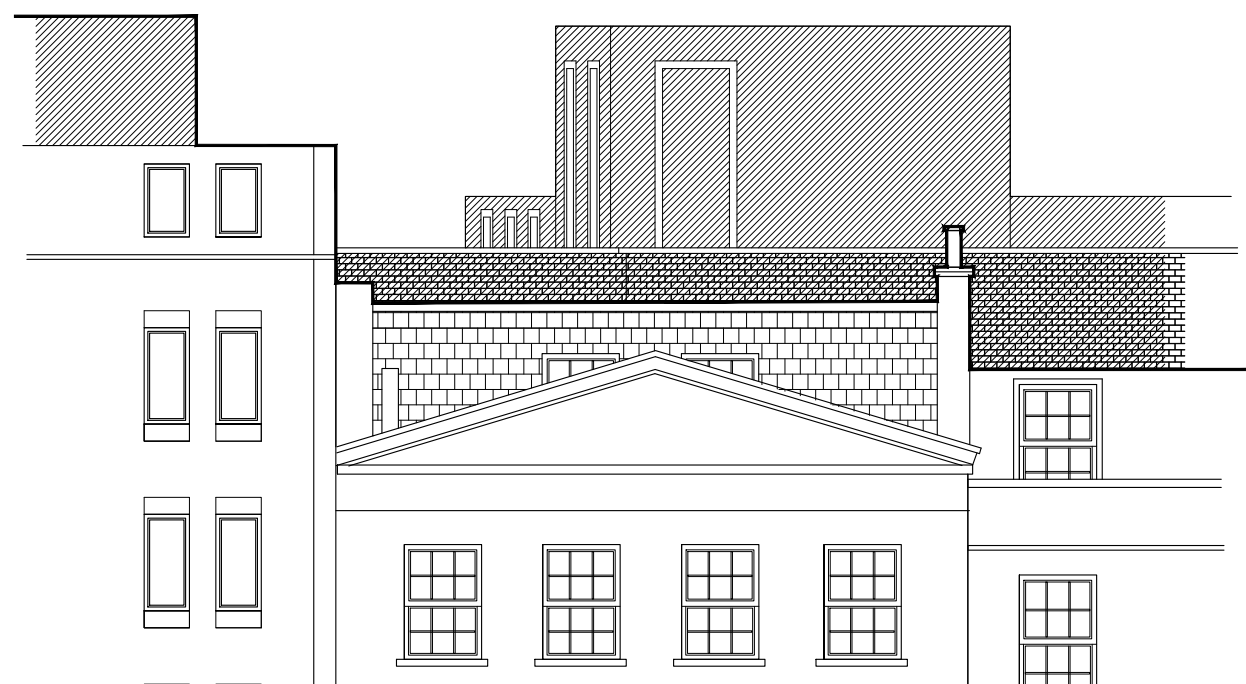

THIS IS THE PROPOSED
ELEVATION
RATIONALIZING THE ROOF
LINE AND EMPHASIZING
THE PEDIMENT AGAINST A
UNIFORM BACKGROUND.

3 PROPOSED ELEVATION POST DEVELOPMENT
Scale: 1:100

ISSUE 1

JL Project
277 GRAYS INN ROAD

JL Drawing Title
ELEVATIONS
BEFORE AND AFTER
DEVELOPMENT AT REAR

Scale	Date	Dwn
1:100@A3	11/07/2018	NH
Drawing No.	Rev.	
813_016		
CAD Ref.	813	



1 EXISTING STREET VIEW
NTS

2 PROPOSED STREET VIEW
NTS



NEIGHBOURING MANSARD
ROOFS MORE PROMINENT

No.277

THE ABOVE VIEWS HAVE BEEN CREATED TO SHOW THE VIEW FROM STREET LEVEL OPPOSITE THE PROPERTY.

227 WAS THE CENTRE PROPERTY OF A LINE OF TERRACE HOUSES AND WAS SET FORWARD AND ELEVATED. SUBSEQUENT BUILDING WORKS TO THE SURROUNDING BUILDINGS HAVE LESSENNED ITS PROMINENCE. THE AMENDMENTS TO THE ROOF REINSTATE THIS PROMINENCE WHILST KEEPING THE ROOF SUBSERVIENT TO THE PEDIMENT.

ISSUE 1

JL Project
277 GRAYS INN ROAD

JL Drawing Title
EXISTING & PROPOSED
MODEL STREET VIEWS

Scale	NTS	Date	11/07/2018	Dwn	EH
Drawing No.	813_017		Rev.		
CAD Ref.	813				

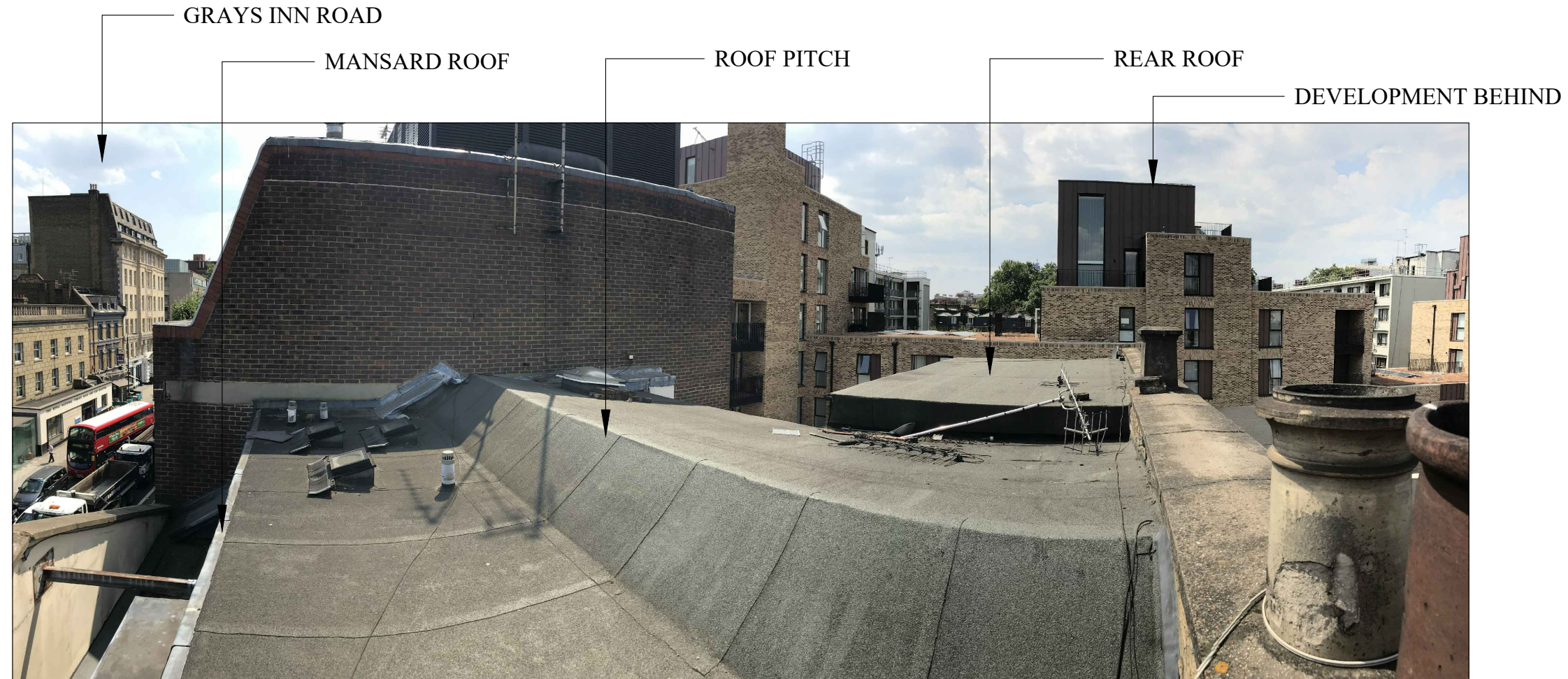

1 EXISTING ROOF
NTS



2 REAR ROOF AND TERRACE
NTS

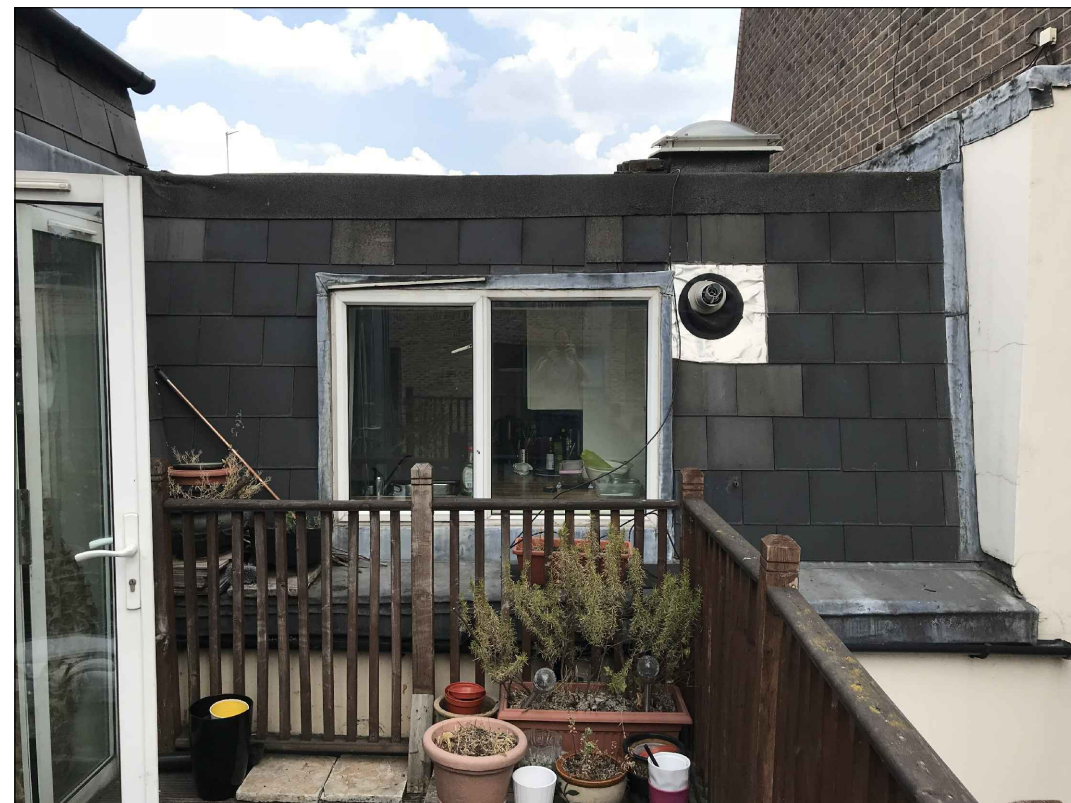

3 AREA OF REAR MANSARD TO BE ADAPTED
NTS

ISSUE 1

JL Project
277 GRAYS INN ROAD

JL Drawing Title
PHOTOGRAPHS
OF ROOF AND
TERRACE

Scale	1:100@A3	Date	11/07/2018	Dwn	NH
Drawing No.	813_020	Rev.			
CAD Ref.	813				