

COMPARISON OF 2003 CONSENT & 2018 PROPOSED DRAWINGS

1:50 2018 PROPOSED - SECTION BB

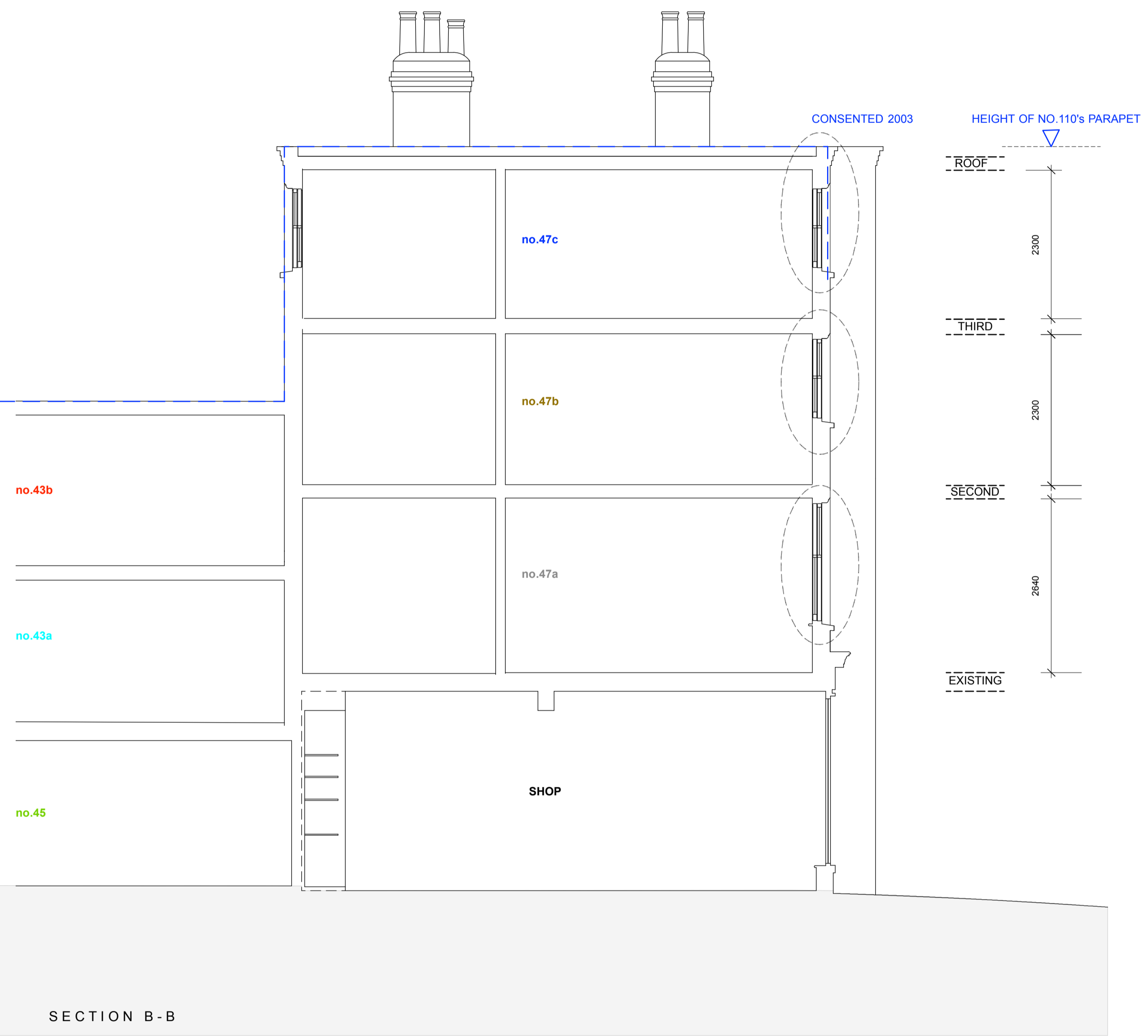

1:50 2003 CONSENT - SECTION BB

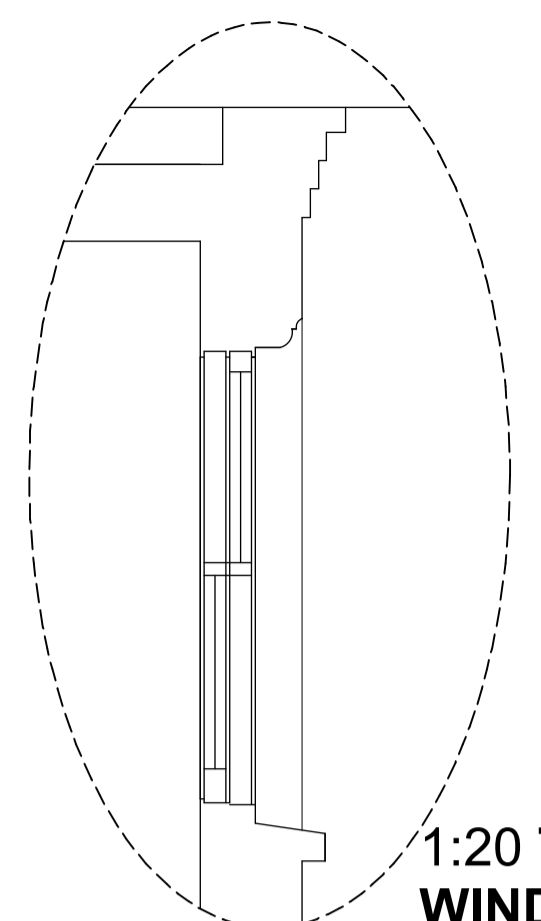
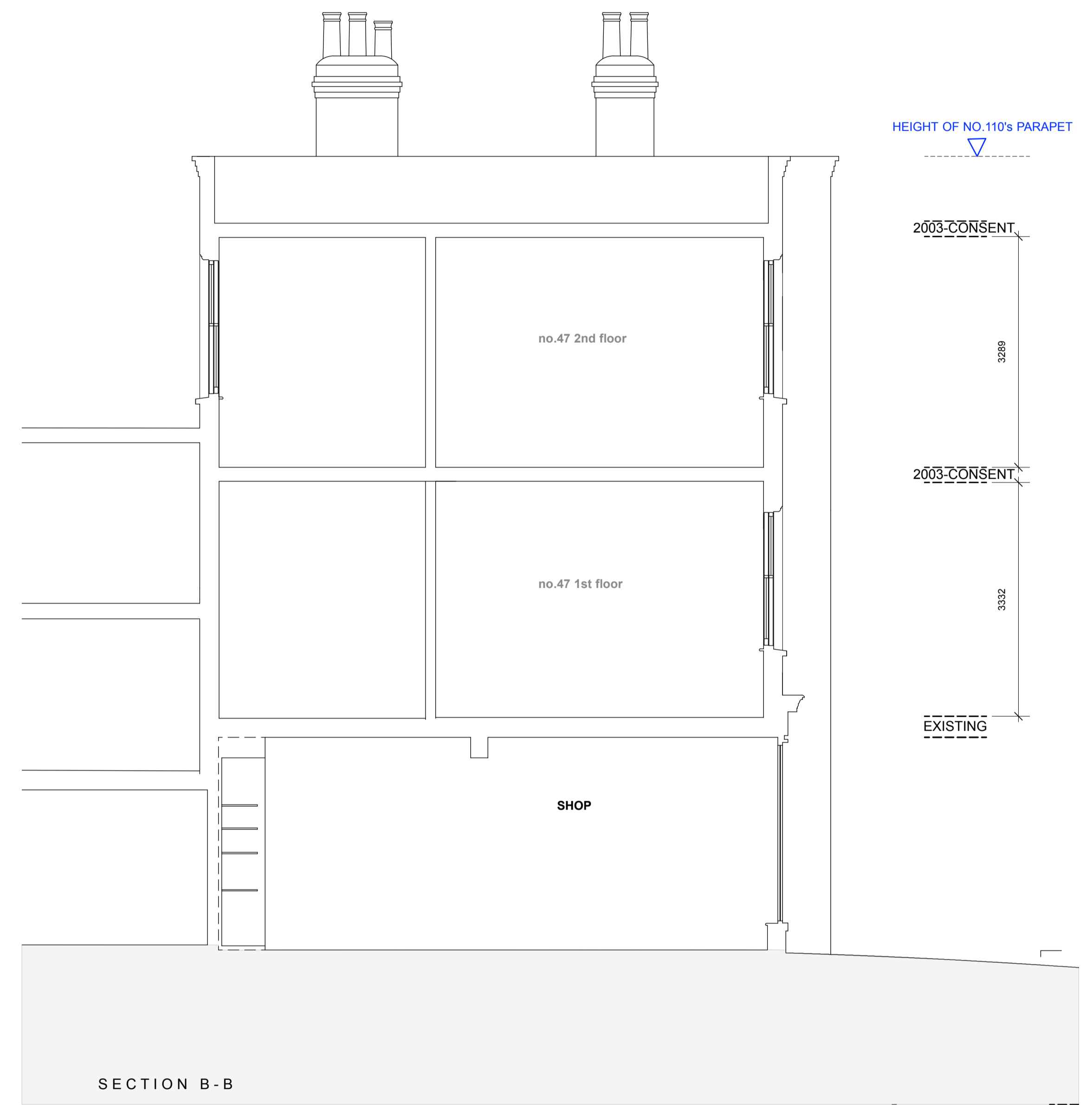

1:20 THIRD FLOOR WINDOW DETAIL

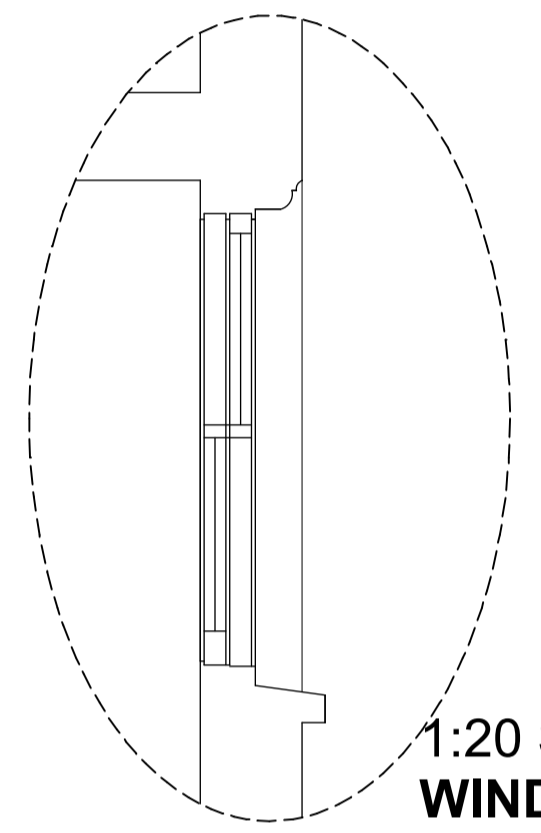

1:20 SECOND FLOOR WINDOW DETAIL

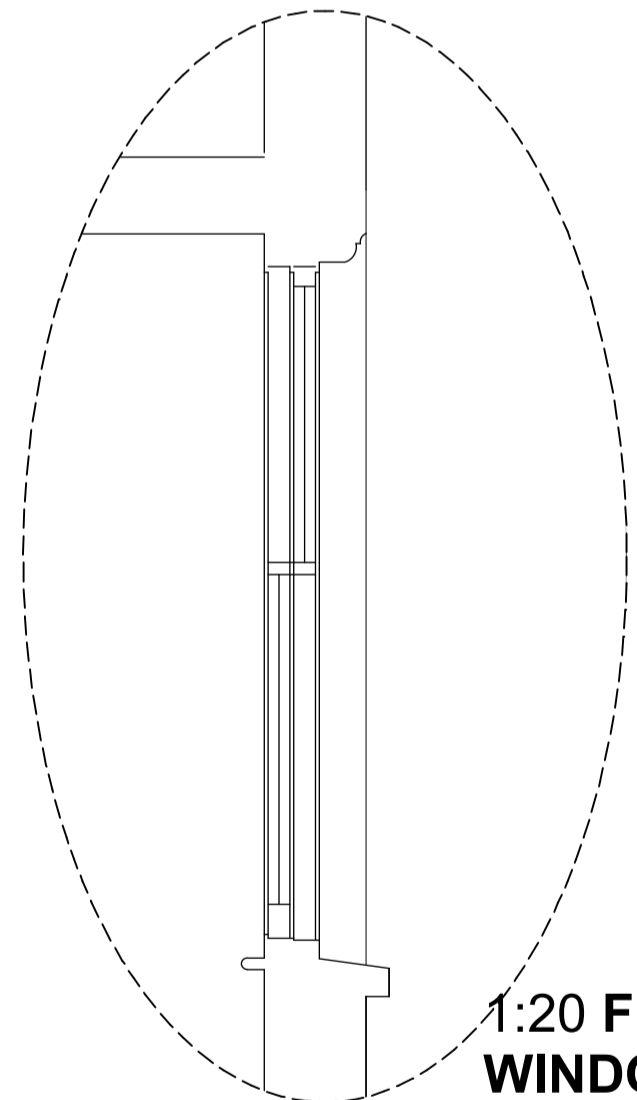

1:20 FIRST FLOOR WINDOW DETAIL

