

INSTRUCTION MANUAL

INSTALLATION COMMISSIONING & SERVICING

FLOOR STANDING RSF GAS-FIRED CONDENSING REGULAR BOILER

GREENSTAR FS 30CDi & FS 42CDi Regular

FOR SEALED OR OPEN VENT CENTRAL HEATING SYSTEMS

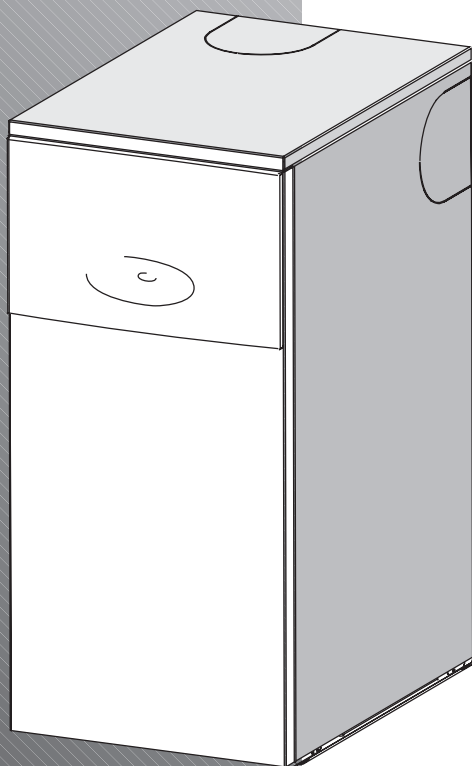

THE APPLIANCE IS FOR USE WITH
NATURAL GAS OR L.P.G. (Cat II 2H3P TYPE C13, C33, C53 & C93)

NATURAL GAS:
GREENSTAR FS 30CDi REGULAR GC NUMBER 41-406-03
GREENSTAR FS 42CDi REGULAR GC NUMBER 41-406-04

LIQUID PETROLEUM GAS:
GREENSTAR FS 30CDi REGULAR GC NUMBER 41-406-05
GREENSTAR FS 42CDi REGULAR GC NUMBER 41-406-06



UK/IE

**WORCESTER**
Bosch Group

CONTACT INFORMATION

WORCESTER, BOSCH GROUP:

RECEPTION: 0844 892 9900
 MAIN FAX: 01905 754619
 TECHNICAL: 0844 892 3366
 SERVICE: 0844 892 3000
 SPARES: 01905 752571
 LITERATURE: 0844 892 9800
 TRAINING: 01905 752526
 SALES: 01905 752640
 WEBSITE: worcester-bosch.co.uk

WATER TREATMENT:

FERNOX 01799 550811
 fernox.com

SENTINEL 0800 389 4670
 sentinel-solutions.net

FLUE TERMINAL GUARDS:

TOWER FLUE COMPONENTS
 VALE RISE, TONBRIDGE, TN9 1TB
 TEL: 01732 351680
 tfc-group.co.uk

IMPORTANT HANDLING INSTRUCTIONS:

It is advised that two people are involved in the transfer of the packaged appliance from the van to the point of installation.

A suitable truck should be used.

The boiler is secured to a wooden board with screws. It is advised that no attempt should be made to move the packaged appliance without the use of a suitable truck.

Before removing the carton it is advised that the top flaps are opened and the ancillary items removed and set to one side.

The carton can now be lifted off the boiler.

Remove the plastic bag protecting the boiler surfaces and place safely away from the working area.

Remove the boiler (complete with board) from the pallet before removing the securing screws.

The boiler is mounted on small wheels and can now be slid off the board and guided into the installation position.

Care should be taken not to damage any panels.

Two people are required to move the appliance from the board into the installation position.

GENERAL HANDLING GUIDELINES:

- Lift only a manageable weight, or ask for help.
- When lifting, bend the knees, and keep the back straight and feet apart.
- Do not lift and twist at the same time.
- Lift and carry items close to the body
- Wear protective clothing and gloves to protect from any sharp edges

Store the appliance in a dry area prior to installation.

INSTALLATION & SERVICING INSTRUCTIONS

PLEASE READ THESE INSTRUCTIONS CAREFULLY BEFORE STARTING INSTALLATION.

THESE INSTRUCTIONS ARE APPLICABLE TO THE PRODUCT MODEL(S) STATED ON THE FRONT COVER OF THIS MANUAL ONLY AND MUST NOT BE USED WITH ANY OTHER MAKE OR MODEL OF APPLIANCE.

THE INSTRUCTIONS APPLY IN THE UK & EIRE ONLY AND MUST BE FOLLOWED EXCEPT FOR ANY STATUTORY OBLIGATION.

THIS APPLIANCE MUST BE INSTALLED BY A COMPETENT REGISTERED ENGINEER, SUCH AS A BRITISH GAS OR OTHER GAS SAFE REGISTERED PERSONNEL.

FAILURE TO INSTALL CORRECTLY COULD LEAD TO PROSECUTION.

IF YOU ARE IN **ANY DOUBT** CONTACT THE WORCESTER TECHNICAL SUPPORT HELPLINE.

DISTANCE LEARNING AND TRAINING COURSES ARE AVAILABLE FROM WORCESTER, PART OF THE BOSCH GROUP.

PLEASE LEAVE THESE INSTRUCTIONS, THE USER GUIDE AND THE COMPLETED BENCHMARK LOG BOOK (AT THE BACK OF THIS MANUAL) OR A CERTIFICATE CONFIRMING COMPLIANCE WITH IS 813 (EIRE ONLY) WITH THE USER OR AT THE GAS METER AFTER INSTALLATION OR SERVICING.

COMMERCIAL INSTALLATION:

IF INSTALLING A GROUP OF APPLIANCES TOGETHER, ON COMMERCIAL PREMISES, THAT TOTALS MORE THAN 70KW, THEN THE APPLIANCES MUST BE INSTALLED IN ACCORDANCE WITH THE REQUIREMENTS OF IGE/UP/10 THEREFORE A COMMERCIAL GAS QUALIFICATION WILL BE REQUIRED.

ABBREVIATIONS:

Ø Diameter
 NG Natural Gas
 LPG Liquid Petroleum Gas
 CH Central Heating
 DHW Domestic Hot Water
 TRV Thermostatic Radiator Valve
 IP Ingress Protection
 RSF Room sealed flue
 N/A Not allowed
 SEDBUK Seasonal Efficiency for Domestic Boilers in the United Kingdom

SYMBOLS USED IN THIS MANUAL:



Domestic hot water



Programmer ON CH only



Central heating



Programmer ON DHW only



Room thermostat

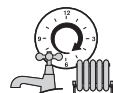

Programmer ON CH and DHW



Frost thermostat



Cold water main supply



Wait time period



Electricity supply



Programmer/timer OFF



Fuel supply

CONTENTS

SAFETY & REGULATIONS	
SAFETY PRECAUTIONS	2
INSTALLATION REGULATIONS	2
APPLIANCE INFORMATION	
GENERAL INFORMATION	3
TECHNICAL DATA	4
LAYOUT & COMPONENTS	5
PRE-INSTALLATION	
CLEANING PRIMARY SYSTEMS	6
MAINS SUPPLIES	7
WATER SYSTEMS & PIPEWORK	8
CONDENSATE PIPEWORK	10
BOILER LOCATION & CLEARANCES	11
MOUNTING FRAME CONNECTIONS	13
FLUE OUTLET POSITIONS	14
ROOM SEALED FLUE OPTIONS	16
INSTALLATION	
UNPACKING THE BOILER	17
MOUNTING FRAME FIXING / FLUE OPENING	18
MOUNTING FRAME CONNECTIONS	19
FLUE LENGTHS/FLUE MEASURING & CUTTING	20
FLUE INSTALLATION	23
STANDARD FLUE INSTALLATION	24
FLUE TERMINAL PLUME MANAGEMENT	25
CONDENSATE, GAS & WATER CONNECTIONS	26
ELECTRICAL	27
COMMISSIONING	
PRE-COMMISSIONING CHECKS	28
FILLING THE SYSTEM	29
STARTING THE APPLIANCE	30
WATER TREATMENT	31
FINISHING COMMISSIONING	32
SERVICING & SPARES	
INSPECTION AND SERVICE	33
REPLACEMENT OF PARTS	37
SETTING THE GAS/AIR RATIO	42
SHORT PARTS LIST	43
CONVERSION KITS	
L.P.G. CONVERSION	44
FAULT FINDING & DIAGRAMS	
ELECTRICAL WIRING DIAGRAM	45
CENTRAL HEATING FUNCTION	46
FAULT FINDING	47
BENCHMARK CHECKLIST AT REAR OF MANUAL	

SAFETY & REGULATIONS

APPLIANCE INFORMATION

PRE-INSTALLATION

INSTALLATION

COMMISSIONING

SERVICING & SPARES

CONVERSION KITS

FAULT FINDING & DIAGRAMS

SAFETY PRECAUTIONS

IF YOU SMELL GAS:

- X** DO NOT SMOKE OR STRIKE MATCHES.
- X** DO NOT TURN ELECTRICAL SWITCHES ON OR OFF.
- ✓ PUT OUT NAKED FLAMES.
- ✓ OPEN DOORS AND WINDOWS.
- ✓ KEEP PEOPLE AWAY FROM THE AREA AFFECTED.
- ✓ TURN OFF THE CONTROL VALVE AT THE METER.
- ✓ CALL YOUR GAS COMPANY.
- OR-
- ✓ CALL 0800 111 999 NATIONAL GRID EMERGENCY SERVICES.

BOILER OPERATION:

This boiler must only be operated by a responsible adult who has been instructed in, understands and is aware of the boiler's operating conditions and effects.



BENCHMARK:

Benchmark places responsibilities on both manufacturers and installers. The purpose is to ensure that customers are provided with the correct equipment for their needs, that it is installed, commissioned and serviced in accordance with the manufacturer's instructions by competent persons and that it meets the requirements of the appropriate Building Regulations. The Benchmark Checklist can be used to demonstrate compliance with Building Regulations and should be provided to the customer for future reference. Installers are required to carry out installation, commissioning and servicing work in accordance with the Benchmark Code of Practice which is available from the Heating and Hotwater Industry Council who manage and promote the scheme. Visit www.centralheating.co.uk for more information.

IMPORTANT: The completed Benchmark Log Book will be required in the event of any warranty work and may be required by the local Building Control Inspector.

HEALTH & SAFETY:

The appliance contains no asbestos and no substances have been used in the construction process that contravene the COSHH Regulations (Control of Substances Hazardous to Health Regulations 1988). Where applicable, the CE mark indicates compliance with relative EU Directives.

COMBUSTIBLE AND CORROSIVE MATERIALS:

Do not store or use any combustible materials (paper, thinners, paints etc.) inside or within the vicinity of the appliance.

The combustion air must be kept clear of chemically aggressive substances, which can corrode the appliance and invalidate any warranty.

FITTING & MODIFICATIONS:

Fitting the appliance and any controls to the appliance may only be carried out by a competent engineer in accordance with these instructions and the relevant Installation Regulations.

Flue systems must not be modified in any way other than as described in the fitting instructions.

Any misuse or unauthorised modifications to the appliance, flue or associated components and systems could invalidate the warranty. The manufacturer accepts no liability arising from any such actions, excluding statutory rights.

SERVICING:

Advise the user to have the system regularly serviced by a competent, qualified engineer (such as British Gas or other GAS SAFE registered personnel) using approved spares, to help maintain the economy, safety and reliability of the appliance.

IMPORTANT - The service engineer must complete the Service Record in the Benchmark Log Book after each service.

INSTALLATION REGULATIONS

Failure to install appliances correctly could lead to prosecution.

This appliance must be installed by a competent registered engineer, such as British Gas or other GAS SAFE registered personnel, in accordance with, and comply to, the current: Gas Safety (Installation & Use) Regulations 1998, IEE Regulations, Building Regulations, Building Standards (Scotland) (Consolidation), Building Regulations (Northern Ireland), local water by-laws, Health & Safety Document 635 (The Electricity at Work Regulations 1989), IS 813 (Eire) and any other local requirements.

The relevant Standards should be followed, including:

BS7074:1 : Code of practice for domestic heating and hot water supply

BS6891 : Installation of low pressure gas pipework up to 32mm (R11/4)

BS EN:12828 : Central heating for domestic premises

BS5440:1 : Flues and ventilation for gas appliances of rated heating not exceeding 70kW (net) : Flues

BS5440:2 : Flues and ventilation for gas appliances of rated heating not exceeding 70kW (net) : Air Supply

BS7593 : Treatment of water in domestic hot water central heating systems

BS6798 : Installation of gas fired boilers of rated input up to 70kW (net)

Where no specific instruction is given, reference should be made to the relevant codes of Practice.

L.P.G. Installation:

An appliance using L.P.G. must not be installed in a room or internal space below ground level unless one side of the building is open to the ground.

Timber framed buildings:

Where the boiler is to be fitted to a timber framed building the guidelines laid down in BS5440: Part 1 and IGE "Gas Installations in Timber Frame Buildings" should be adhered to.

IMPORTANT:

Artificially softened water must not be used to fill the central heating system.

GENERAL INFORMATION

STANDARD PACKAGE:

- A - Floor standing gas fired regular boiler
- B - Mounting frame complete with pre-plumbing manifold assembly
- C - Literature pack
- D - Condensate hose and non-return valve

SPECIFICATIONS:

- Pre-wired and pre-plumbed.
- Galvanised steel inner frame.
- Bosch Heatronic control system.
- Automatic ignition.
- Direct burner ignition electrodes.
- Built-in frost thermostat.
- Built-in fault finding diagnostics.
- Modulating automatic gas valve.
- Combustion air fan with speed regulator.
- CH temperature sensor & control.
- Flue gas temperature limiter.
- Condensate trap & pump.

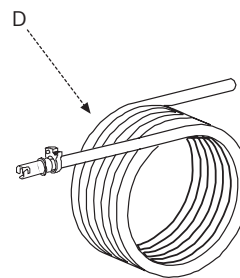
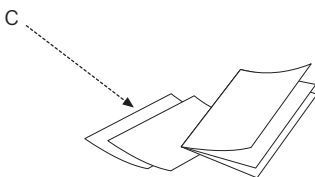
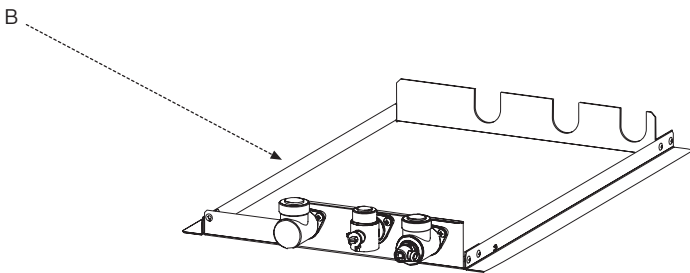
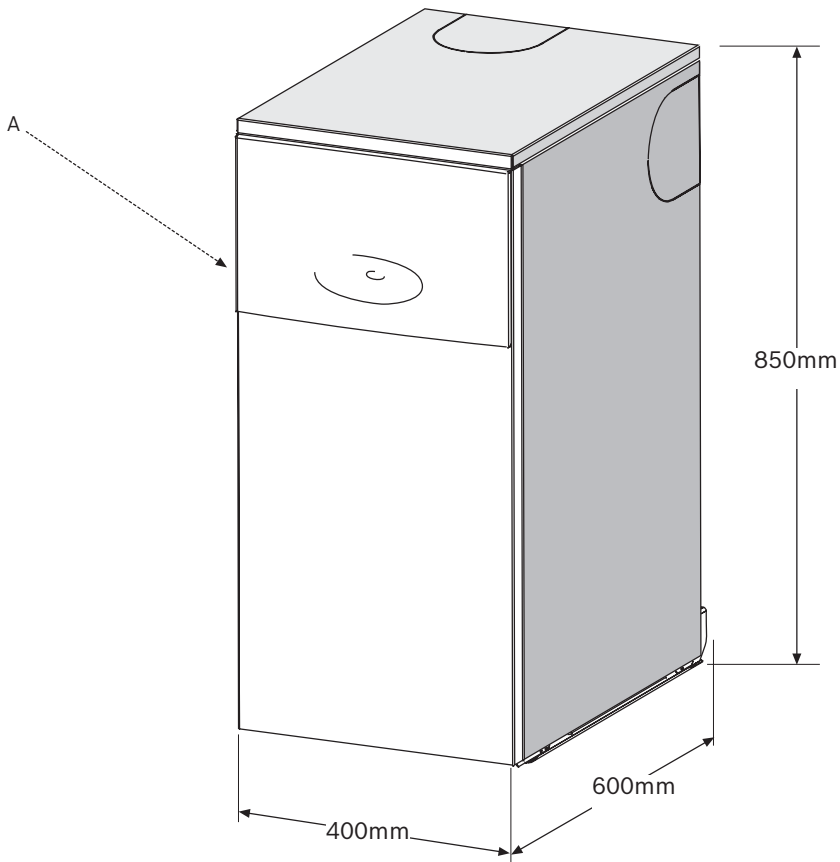

TECHNICAL DATA

DESCRIPTION	UNITS	Natural Gas		L.P.G	
		FS 30CDi	FS 42CDi	FS 30CDi	FS 42CDi
Central Heating					
Max. rated heat output net 40/30°C	kW	32.1	43.7	32.1	43.7
Max. rated heat output net 50/30°C	kW	31.8	43.3	31.8	43.3
Max. rated heat output net 80/60°C	kW	30	40.8	30	40.8
Max. rated heat input net	kW	30.9	42	30.9	42
Min. rated heat output net 40/30°C	kW	8.6	10.8	11.6	13.5
Min. rated heat output net 50/30°C	kW	8.6	10.7	11.4	13.4
Min. rated heat output net 80/60°C	kW	7.7	9.6	10.5	12.0
Min. rated heat input net	kW	8	10	10.8	12.5
Max. flow temperature	°C	88	88	88	88
Max. permissible operating pressure	bar	2.65	2.65	2.65	2.65
Gas flow rate - Max. 10 minutes from lighting					
Natural Gas G20	m ³ /h	3.27	4.4	-	-
Propane Gas (LPG)	kg/h	-	-	2.3	3.3
Gas supply pressure					
Natural Gas G20	mb	20	20		
LPG (Propane) Gas G31	mb	-	-	37	37
Flue					
Flue Gas Temp. 80/60°C, rated min. load	°C	67/55	67/55	67/55	67/55
Flue Gas Temp. 40/30°C, rated min. load	°C	43/32	43/32	43/32	43/32
CO ₂ level at max. rated heat output	%	9.4	9.4	10.8	10.8
CO ₂ level at min. rated heat output	%	8.6	9.0	10.4	10.4
NO _x - classification	class	5	5	5	5
Condensate					
Max. condensation rate	l/h	2.7	3.7	2.7	3.7
pH value, approx.		4.8	4.8	4.8	4.8
Electrical					
Electrical power supply voltage	AC...V	230	230	230	230
Frequency	Hz	50	50	50	50
Max. power consumption (without pump)	W	60	80	60	80
General Data					
SEDBUK (Band A)	%	90.5	90.3	91.9	91.1
Appliance protection rating	IP	x4D	x4D	x4D	x4D
Permissible ambient temperatures	°C	0 - 50	0 - 50	0 - 50	0 - 50
Nominal capacity of appliance	ltr	3.75	3.75	3.75	3.75
Noise output level (at maximum CH output)	dB(A)	37	37	37	37
Weight (excluding packaging)	kg	55.1	55.1	55.1	55.1

LAYOUT & COMPONENTS

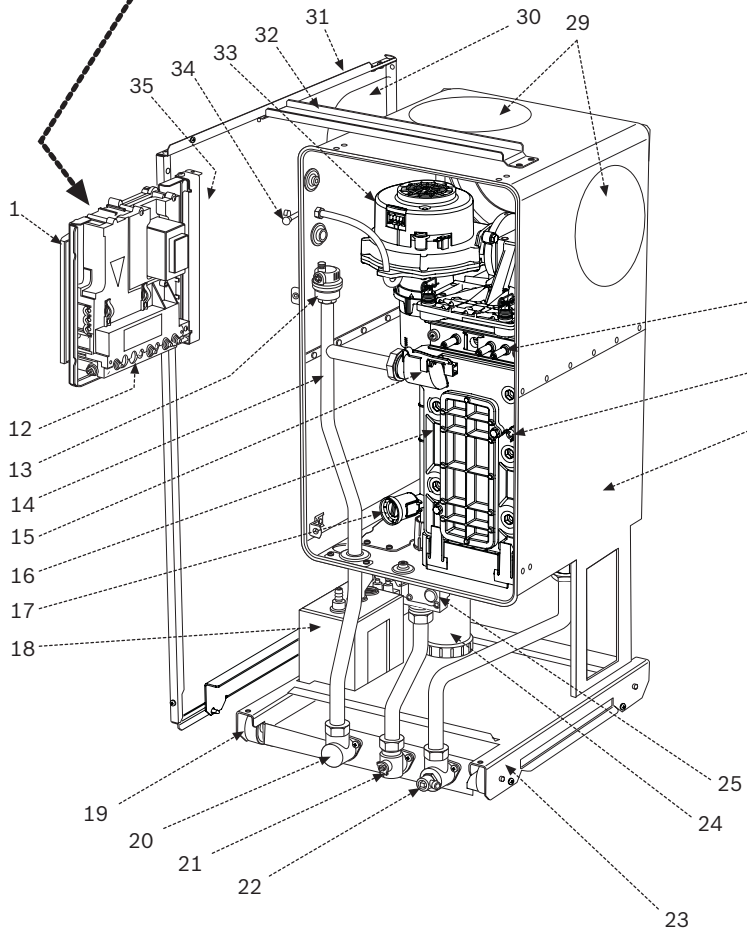
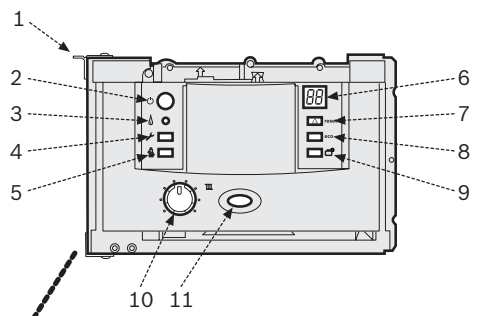
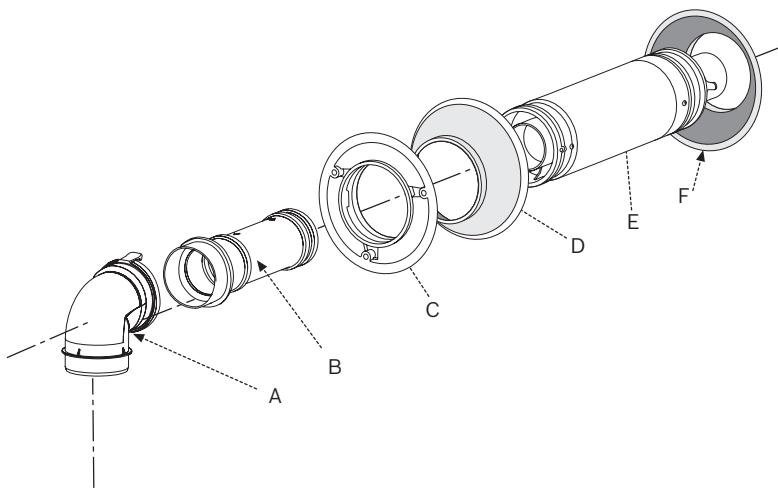

The diagram opposite shows the controls in the servicing position and excludes the outer case, inner covers and wiring.

- 1 CONTROL PANEL
- 2 MASTER SWITCH FOR ON/OFF
- 3 BURNER ON INDICATOR LIGHT (GREEN)
- 4 SERVICE BUTTON
- 5 BOOST BUTTON (SERVICE ONLY)
- 6 DISPLAY
- 7 RESET BUTTON
- 8 NOT USED
- 9 NOT USED
- 10 TEMPERATURE CONTROL
- 11 MAINS ON/OFF INDICATOR & FAULT DIAGNOSTIC LIGHT (BLUE)
- 12 BOSCH HEATRONIC III SERIES CONTROL BOARD
- 13 AUTO-AIR VENT
- 14 FLOW PIPE
- 15 THERMISTOR
- 16 HEATCELL
- 17 AIR/GAS ADJUSTMENT SCREW (SEALED)
- 18 CONDENSATE PUMP ASSEMBLY
- 19 RUNNER WHEEL
- 20 FLOW CONNECTION
- 21 GAS ISOLATION VALVE
- 22 RETURN CONNECTION
- 23 MOUNTING FRAME
- 24 CONDENSATE SIPHON
- 25 GAS VALVE
- 26 INNER CASING
- 27 HEATCELL HIGH LIMIT THERMOSTAT
- 28 BURNER IGNITION ELECTRODES
- 29 BLANKING COVERS - FLUE OUTLET
- 30 CASE 'KNOCK-OUT' PANEL - FLUE
- 31 CASE SIDE PANEL LEFT HAND
- 32 CASING SUPPORT STRUT
- 33 COMBUSTION AIR MODULATING FAN
- 34 FLUE GAS SAMPLING POINT
- 35 DATA LABEL

100mmØ HORIZONTAL FLUE COMPONENTS (Kit Part No. 7 716 191 155)

- A - 90° ELBOW
- B - ADAPTOR
- C - CONNECTOR
- D - INNER WALL FLUE COLLAR
- E - TELESCOPIC TERMINAL ASSEMBLY
- F - OUTER WALL FLUE COLLAR

FLUE KITS:

Vertical 100mmØ	Part No. 7 716 191 156
Vertical 125mmØ	Part No. 7 716 191 158
Horizontal 125mmØ	Part No. 7 716 191 157
80mmØ Flexible flue	Part No. 7 716 191 159
Plume management kit	Part No. 7 716 191 086

IMPORTANT: All the following pre-installation sections must be read and requirements met before starting boiler or flue installation.

CAUTION: ISOLATE THE MAINS SUPPLIES BEFORE STARTING ANY WORK AND OBSERVE ALL RELEVANT SAFETY PRECAUTIONS.

CLEANING PRIMARY SYSTEMS

IMPORTANT:

Debris from the system can damage the boiler and reduce efficiency. Failure to comply with the guidelines for the use of water treatment with the appliance will invalidate the appliance warranty.

BEFORE CLEANING THE SYSTEM:

ENSURE THE SYSTEM AND PIPEWORK ARE IN GOOD WORKING ORDER.

USE THE EXISTING BOILER/CIRCULATING PUMP WHERE POSSIBLE OR USE A POWER FLUSHING MACHINE TO AID THE CLEANSING PROCEDURE BEFORE INSTALLING A NEW BOILER.

CLEANING THE PRIMARY SYSTEM

IMPORTANT: ARTIFICIALLY SOFTENED WATER MUST NOT BE USED TO FILL THE CENTRAL HEATING SYSTEM.

- ▶ Fill the system with cold mains water to the recommended pressure and check for leaks.
- ▶ Open all drain cocks and drain the system.
- ▶ Close drain cocks and add a suitable flushing agent at the correct strength for the system condition in accordance with the manufacturer's instructions.
- ▶ Circulate the flushing agent before the boiler is fired up.
- ▶ Run the boiler and system at normal operating temperature in accordance with the manufacturer's instructions.
- ▶ Drain and thoroughly flush the system to remove the flushing agent and any debris.



ELECTRICAL SUPPLY:

- Supply: 230V - 50Hz.
- Cable: PVC insulated 0.75mm² (24 x 0.2mm) temperature rated to 90°C.
- External 3A fuse to BS1362.
- The appliance must be earthed.
- It must be possible to isolate the appliance from the electrical supply with at least a 3mm contact separation in both poles supplying the appliance.
- Wiring between the appliance and the electrical supply must comply with IEE wiring regulations and any local regulations which may apply for fixed wiring to a stationary appliance.
- External pump must be wired back to the boiler.
- Any system connected to the boiler must not have a separate electrical supply.



WATER SUPPLY:

- Connections to the water supply must not be made without the authority of the local water company.



GAS SUPPLY:

- Boilers using NG must be connected to a governed meter.
- LPG boilers must be connected to a regulator.
- Installation and connection of the gas supply to the boiler must be in accordance with BS6891.
- Under no circumstances should the diameter of the gas supply pipe be less than that of the appliance inlet connection.
- The meter or regulator and pipework to the boiler must be checked, preferably by the gas supplier to ensure it is in good working order and can meet the gas flow and pressure requirements in addition to the demand from any other appliance being served.

PRIMARY SYSTEM PLASTIC PIPEWORK:

- Any plastic pipework must have a polymeric barrier with 600mm (minimum) length of copper pipe connected to the boiler.
- Plastic pipework used for underfloor heating must be correctly controlled with a thermostatic blending valve limiting the temperature of the circuits to approx. 50°C. The pipework from the boiler to the blending valve must be in copper.

PRIMARY SYSTEM CONNECTIONS/VALVES:

- Do not use galvanised pipes or radiators.
- All system connections, taps and mixing valves must be capable of sustaining a pressure of 3 bar.
- Radiator valves should conform to BS2767:10.
- All other valves should conform to BS1010.
- On new installations TRV's must be used on all radiators except the radiator where the room thermostat is sited, this must be fitted with lockshield valves and left open. All installations should, at least, have TRV's fitted to radiators within the sleeping accommodation.
- An automatic bypass valve must be connected between the heating flow and return where TRV's are used on all radiators unless one of the parts is open to flow (refer to "Water Systems and Pipework section).
- A drain cock should be fitted at all the lowest points of the heating circuit.
- Air vents are required at all high points on the system.

FILLING PRIMARY SEALED SYSTEMS:

- Filling the primary system must comply with one of the methods shown opposite.
- The filling point must be at low level and must never be a permanent direct fixing to the mains water supply.
- Filling loops must be WRAS approved.

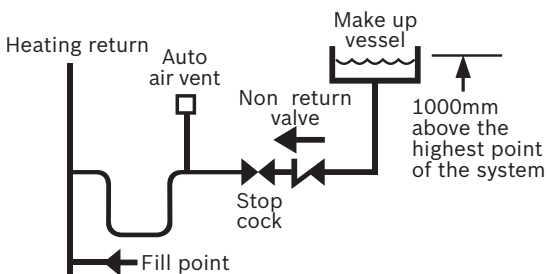
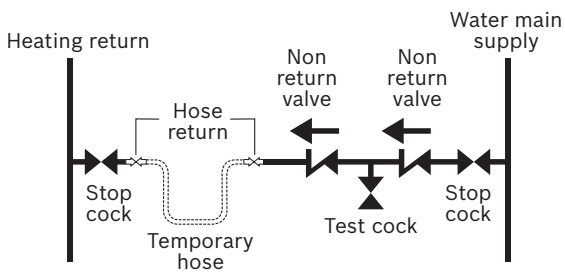

S PLAN LAYOUT

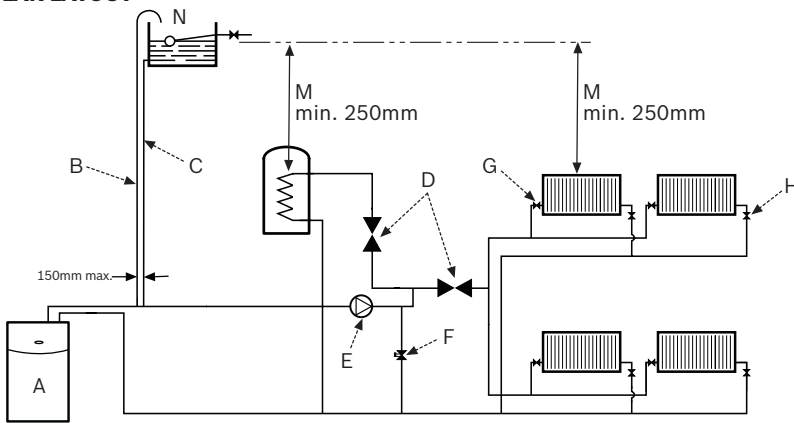

Y PLAN LAYOUT

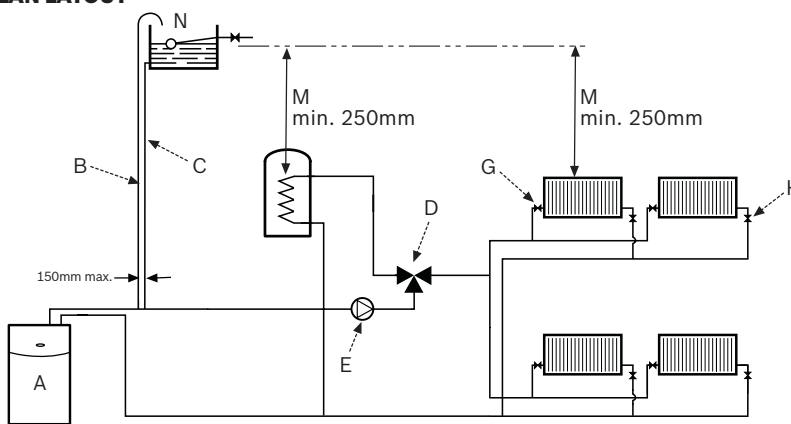

SEALED SYSTEM LAYOUT

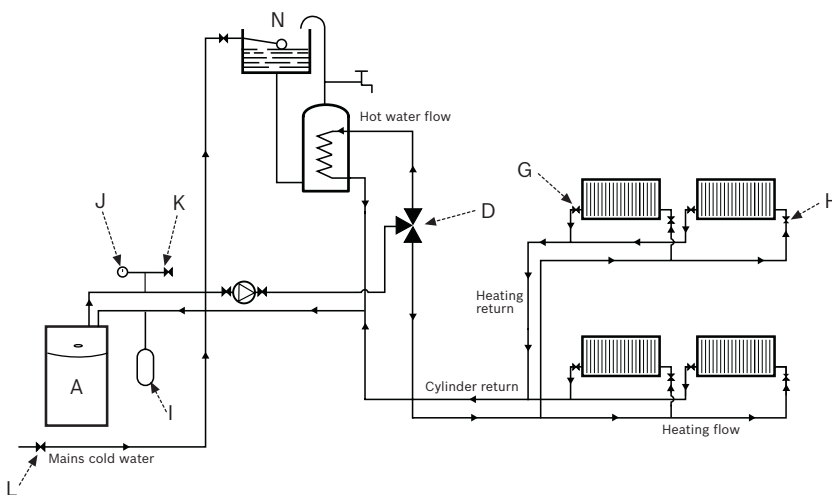

- A - Boiler.
- B - Heating vent (min. Ø22mm).
- C - Primary cold feed (min. Ø15mm).
- D - Diverter valve.
- E - Pump.
- F - Automatic by-pass.
- G - Radiator valve (flow).
- H - Lockshield valve (return).
- I - Expansion vessel.
- J - Pressure gauge.
- K - Relief valve.
- L - Stop valve.
- M - Static head.
- N - Feed & expansion cistern.

S & Y PLAN OPEN VENT PRIMARY SYSTEM:

Generally a by-pass is not necessary on a Y plan system as one of the parts is open to flow.

- The feed and expansion cistern (N) must be positioned to provide a static head (M) of at least 250mm above the highest point in the heating system.
- The heating vent (B) and cold feed (C) pipes must rise continuously from the appliance.
- The heating vent pipe (B) must be at least Ø22mm.
- No valve shall be fitted in the heating vent pipe (B) or the cold feed and expansion pipe (C).

FULLY PUMPED SEALED PRIMARY SYSTEM:

- A pressure relief valve (K) (spring loaded safety valve set to operate at 3 bar) must be fitted to the heating return pipe as close as possible to the boiler.
- An expansion vessel (I) must be fitted to the heating return pipe close to the boiler and pressurised for the system volume according to the instructions supplied with the vessel.
- A pressure gauge (J) (3 bar min.) must be fitted to the heating return pipe.
- An automatic air vent must be fitted.
- Stop valve (L) must be a fixed cylinder type or sealed systems approved connection.

PRE-INSTALLATION

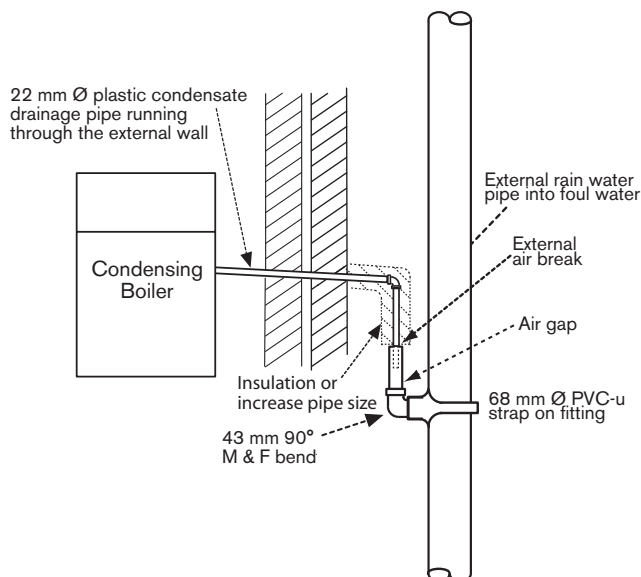
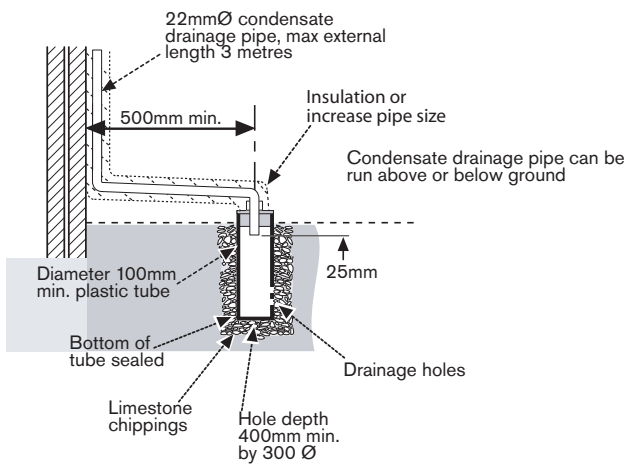
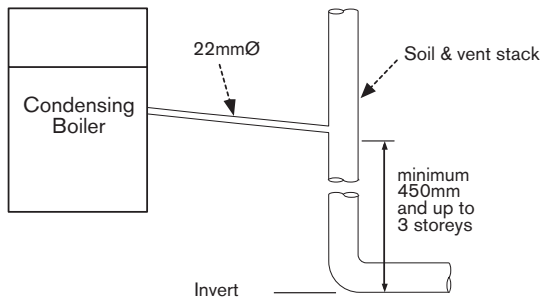
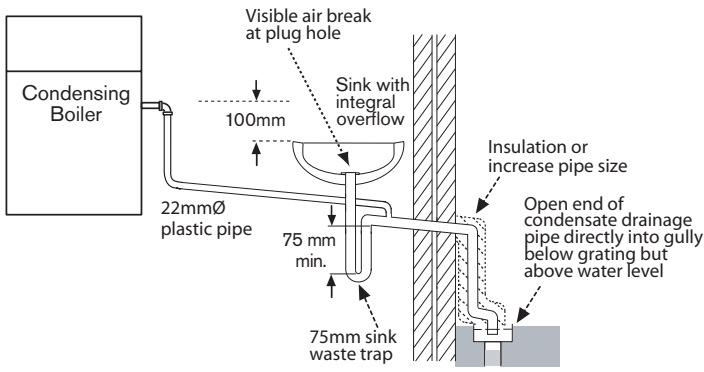

IMPORTANT:

- Ensure there are no blockages in the pipe run
- Care should be taken when siting a soak-away to avoid obstructing existing services
- Condensate waste must not be terminated into a septic tank or cesspit

CONDENSATE PIPEWORK:

- The condensate pipe must be a minimum of 22mm Ø plastic pipe.
- The condensate pipework must fall at least 50 mm per metre towards the outlet and should take the shortest practicable route.
- The pipework must follow one of the options shown opposite or discharge directly into a vent stack min. 450mm above pipe invert or into a gully below ground but above the water level.
- Wherever possible the condensate discharge pipe work should be routed and terminated internally. Should this not be possible, and the only available route is external, the following conditions should be observed:

External pipe work

- Pipe work length should be kept to a minimum and the route as vertical as possible.
 - Where pipe work is subjected to extreme cold or wind chill, a weather proof insulation should be used.
- Alternatively the condensate pipework could be increased to a minimum diameter of 32mm without the requirement to insulate.

Condensate soakaway

The condensate drainage pipe may be run above or below the ground to the soakaway. The example shown opposite runs above ground level.

The soakaway must use a 100mm diameter plastic tube with two rows of three 12mm holes on 25mm centres and 50mm from the bottom of the tube. The holes must face away from the house.

The tube must be surrounded by at least 100mm of limestone chippings to a depth of 400mm.

Fitting an external air break

Use the situation opposite when a rain water down pipe is used to dispose of condensate and the down pipe goes directly into an existing sewer that carries both rainwater and foul water.

An air break must be installed in the 32/43 mm pipework, between the boiler condensate outlet and the drainpipe, outside the property, to avoid flooding during adverse weather conditions.

1: INSTALLATION CLEARANCES

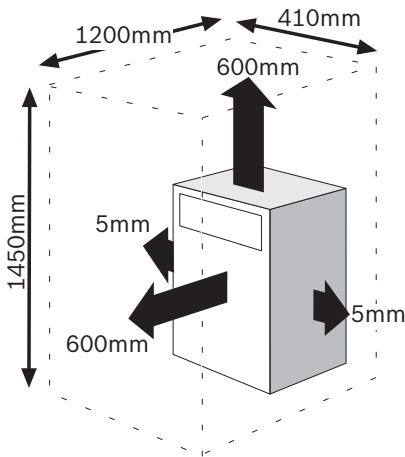

2: SERVICE / VENTED CUPBOARD CLEARANCES

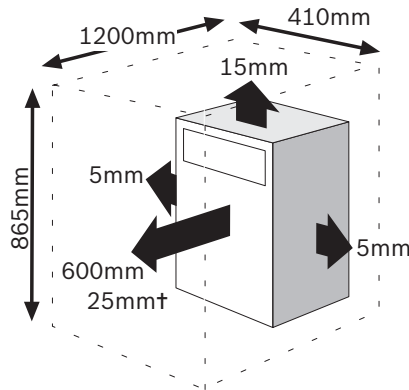

3: UNVENTED COMPARTMENT CLEARANCES

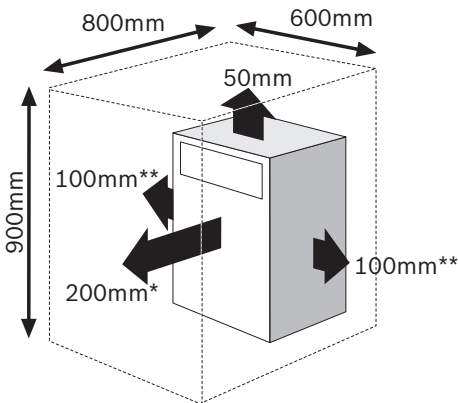

BOILER LOCATION & CLEARANCES

- This boiler is only suitable for installing internally within a property at a suitable location onto a fixed rigid non-combustible surface at least the same size as the boiler and capable of supporting the boiler weight.
- The boiler is not suitable for external installation unless a suitable enclosure is provided.

COMMERCIAL INSTALLATION:

- If installing more than one appliance in a modular or cascade arrangement in a commercial premises, that total more than 70kW, then additional ventilation is needed to comply with the Dangerous Substances and Explosive Atmospheres Regulations (DSEAR).

Compartments:

Follow the requirements of BS6798 and BS5440 Part 2 and note:

- Minimum clearances must be maintained.
- An access door is required to install, service and maintain the boiler and any ancillary equipment.
- If fitting the boiler into an airing cupboard use a non-combustible perforated material (maximum hole sizes of 13mm) to separate the boiler from the airing space.

1: INSTALLATION CLEARANCES:

Diagram 1 shows the minimum space required to install the boiler only.

2: SERVICE / VENTED CUPBOARD CLEARANCES:

Diagram 2 opposite shows the minimum space required to service the boiler only.

† 25mm to a removable door

3: UNVENTED COMPARTMENT CLEARANCES:

Diagram 3 shows the minimum space required to install and service the boiler inside an unvented compartment.

* Space required for unvented areas with a removable door or panel.

** This space can be reduced to 50mm for **one side only** as long as both the side clearances add up to the total of both the side measurements shown or more.

BOILER LOCATION & CLEARANCES

4: AIRING CUPBOARD CLEARANCES

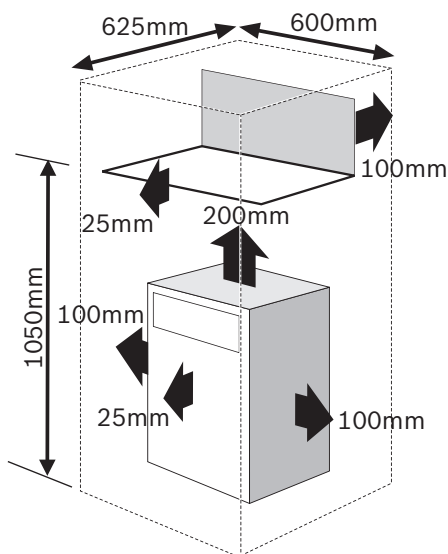

5: VENTING COMPARTMENTS

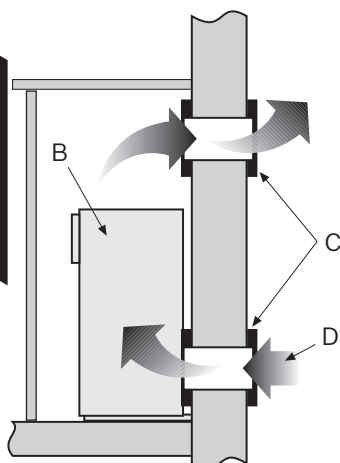

4: AIRING CUPBOARD CLEARANCES:

Diagram '4' opposite shows the minimum space required to install and service the boiler within an airing cupboard.

5: VENTING COMPARTMENTS:

If the clearances are less than those stated for options '3' & '4' (above) then ventilation must be provided as described in BS 5440.

A minimum of 2 air vents (C) of equal size must be fitted, one at low level and another at high level onto the same wall using the same air for circulation.

Minimum free area required for venting:

For air directly from outside:

FS 30CDi 155cm²

FS 42CDi 217cm²

For air from internal space/room:

FS 30CDi 310cm²

FS 30CDi 433cm²

6: BATHROOMS:

IMPORTANT:

Any switch or appliance control using mains electricity must not be within reach of a person using the bath or shower.

Electrical switches, fused spurs and socket outlets must not be situated in the bathroom.

This boiler is IP X4 rated and can be installed in zone 2, however where possible positions outside zone 2 should be sought.

Additional RCD (Residual Current Device) protection may be required.

Refer to the latest IEE wiring regulations.

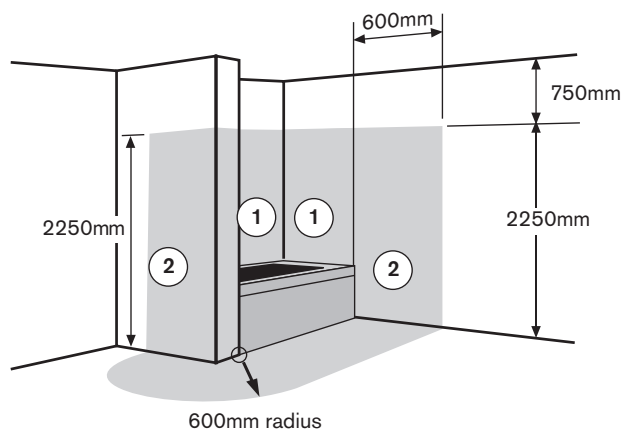
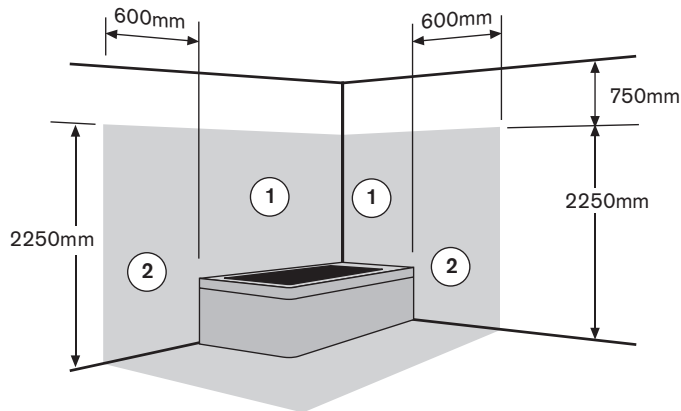

PRE-
INSTALLATION

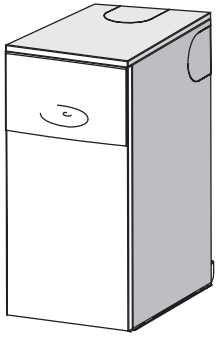

MOUNTING FRAME

CONNECTIONS

CONNECTIONS:

Water: 28mm compression fittings

Gas: 22mm compression fitting.

RUNNING PIPES BEHIND THE BOILER:

- The frame should sit against the wall (not the skirting board) with enough room for the pipework.
- Do not cross a pipe over another.
- The area around a rear flue outlet must be avoided.

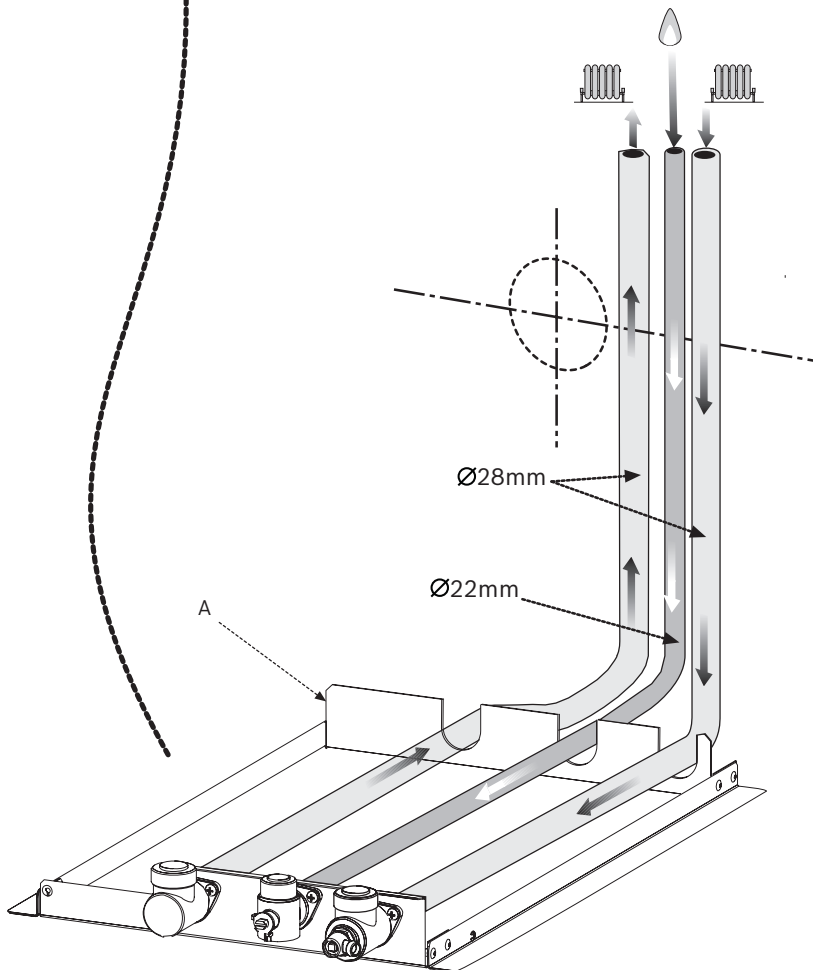

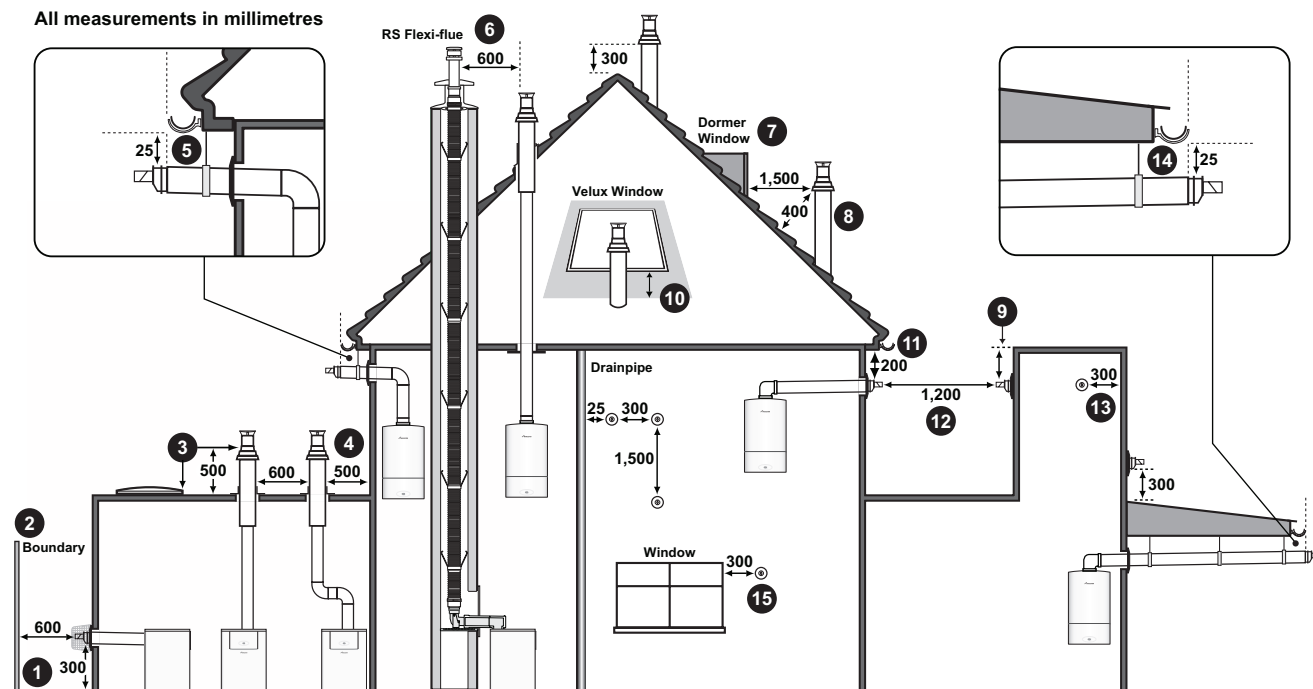

NOTE:

All measurements are the minimum clearances required. Terminals must be positioned so to avoid combustion products entering the building.

Key to illustration

1. Flue clearance must be at least 300mm from the ground. Terminal guards must be fitted if the flue is less than 2 metres from the ground or if a person could come into contact with the flue terminal.
2. 600mm distance to a boundary, unless it will cause a nuisance. BS 5440: Part 1 recommends that care is taken when siting terminals in relation to boundaries.
3. 600mm minimum clearance from a skylight to a vertical flue.
4. Vertical flue clearance 500mm to non-combustible building material, and 1,500mm clearance to combustible building material.
5. The dimension below eaves, gutters, pipes and drains can be reduced to 25 mm, as long as the flue terminal is extended to clear any overhang. Any external flue joints must be sealed with suitable silicon sealant.
6. 500mm clearance to any vertical structure on a roof, 600mm to room sealed flue or 1,500mm to an open flue.
7. 1,500mm between a vertical flue terminal and a window or dormer window.
8. 400mm from a pitched roof or in regions with heavy snow fall 500mm.
9. The flue cannot be lower than 1,000mm from the top of a light well due to the build up of combustion products.
10. 2,000mm below a Velux window, 600mm above or to either side of the Velux window.
11. 200mm below eaves and 75mm below gutters, pipes and drains.
12. 1,200mm between terminals facing each other.
13. 300mm to an internal or external corner.
14. The dimension below eaves, balconies and car ports can be reduced to 25 mm, as long as the flue terminal is extended to clear any overhang. Installations in car ports are not recommended. Any external flue joints must be sealed with suitable silicon sealant.
15. 300mm above, below and either side of an opening door, air vent or opening window.

All measurements in millimetres

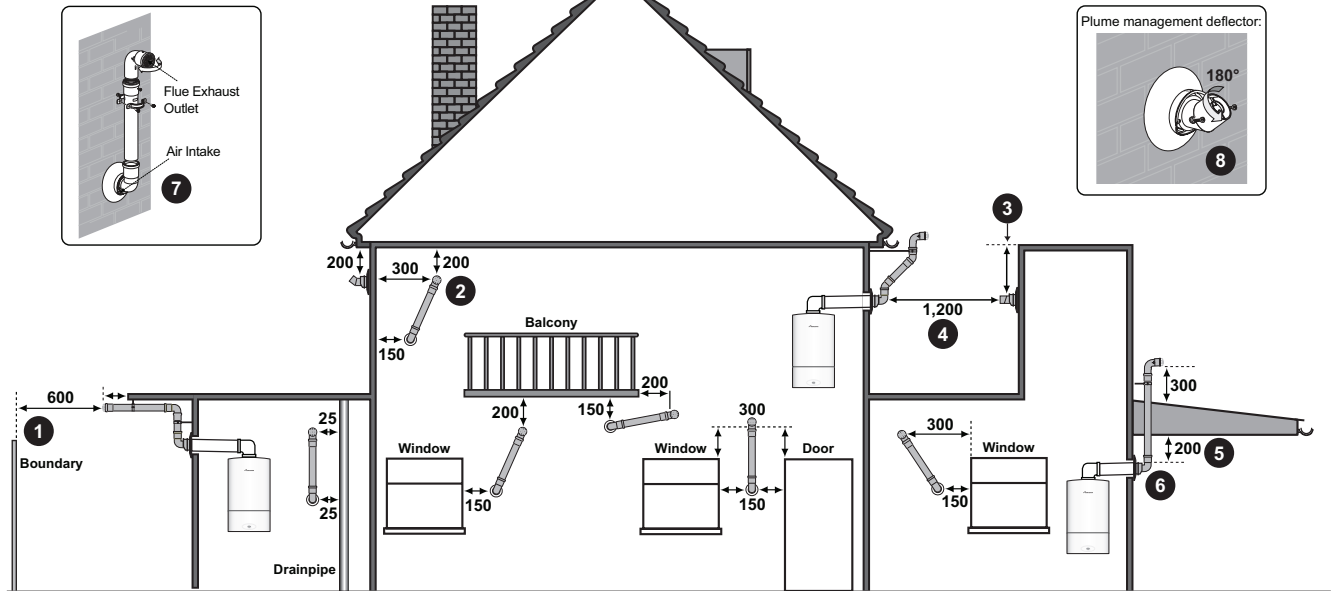

NOTE:
All measurements are the minimum clearances required. Terminals must be positioned so to avoid combustion products entering the building.

Key to illustration

1. 600 mm distance to a boundary, unless it will cause a nuisance. BS 5440: Part 1 recommends that care is taken when siting terminals in relation to boundaries.
2. Internal/external corners the air intake can be reduced to 150mm providing the flue exhaust outlet has a 300mm clearance.
3. The flue cannot be lower than 1,000mm from the top of the light well due to the build up of combustion products.
4. 1,200mm between air intake and facing terminal.
5. Clearance no less than 200mm from the lowest point of the balcony or overhang, installations in car ports are not recommended.
6. 1,200mm from an opening in a car port on the same wall i.e. door or window leading into dwelling. 600mm to a surface facing a terminal.

7. Using a Plume Management Kit the air intake measurement can be reduced to 150mm providing the flue exhaust outlet has a 300mm clearance.

Plume kits running horizontally must have a 10 degree fall back to the boiler for proper disposal of condensate.

For details on specific lengths see relevant boiler Technical & Specification manual.

8. This allows some basic plume options on a standard telescopic horizontal flue terminal. 300mm minimum clearances to a opening e.g. window.

However the minimum clearance to an opening in the direction to which the plume is directed in, should be increased to 1,500mm.

Where the flue is less than 150mm to a drain pipe & the plume deflector is used it should not be directed towards it.

PRE-INSTALLATION

ROOM SEALED FLUE OPTIONS

L = Ø100mm 130 - 530mm
L = Ø125mm 350 - 1200mm

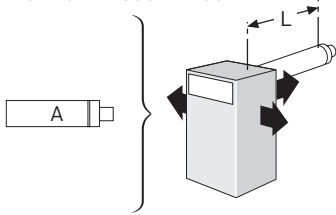

L = Ø125mm 9000mm

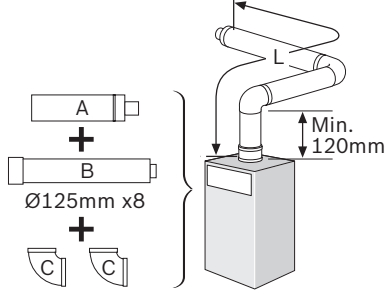

The diagrams (opposite) show the components used and the maximum flue length for each configuration of 100mm and 125mm flues.

- Only straight flue sections can be reduced in length by cutting.
- The 100mm horizontal flue terminal can be fitted from inside or outside the building.

IMPORTANT:

All horizontal sections must rise away from the boiler by 52mm per metre (3°) to allow the condensate to drain back to the boiler.

L = Ø100mm 310 - 4000mm
L = Ø125mm 350 - 13000mm

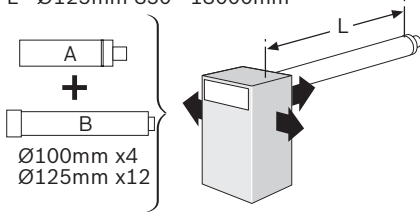

L = Ø125mm 7000mm

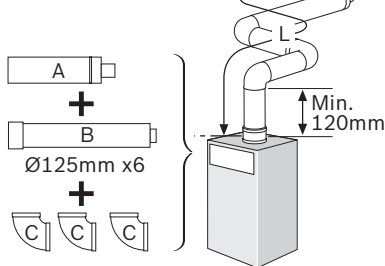

- A - Horizontal terminal
- B - Straight flue extension
- C - Flue bend 90°
- D - Flue bend 45°
- E - Vertical Terminal

Calculating the flue length:

Measure the total flue length (L) required, noting that the maximum straight flue length including the terminal is:

- Horizontal Ø60/100mm: 4000mm
- Horizontal Ø80/125mm: 13000mm
- Vertical Ø60/100mm: 6400mm
- Vertical Ø80/125mm: 15000mm

Then reduce the total straight flue length for each extra flue bend (excluding the flue elbow) by:

2000mm for 90°
1500mm for each 90 bend
1000mm for 45°
750mm for each 45 bend

Flue Extension lengths:

- Horizontal & Vertical Ø60/100mm: 950mm
- Horizontal & Vertical Ø80/125mm: 950mm

Flue Terminal lengths:

- Horizontal Ø60/100mm: 530mm
- Horizontal Ø80/125mm: 1200mm
- Vertical Ø60/100mm: 1140mm
- Vertical Ø80/125mm: 1365mm

L = Ø100mm 2000mm
L = Ø125mm 11000mm

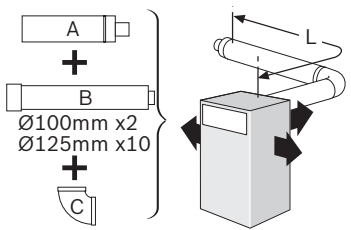

L = Ø100mm 4400mm
L = Ø125mm 13000mm

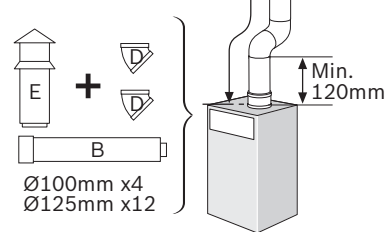

L = Ø100mm 2000mm
L = Ø125mm 11000mm

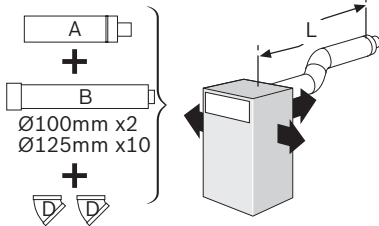

L = Ø100mm 2400mm
L = Ø125mm 11000mm

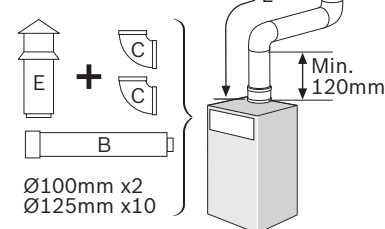

L = Ø125mm 9000mm

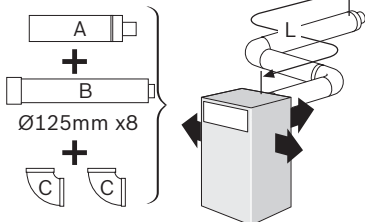

IMPORTANT: All the previous Pre-Installation sections must be read and requirements met before starting boiler or flue installation.

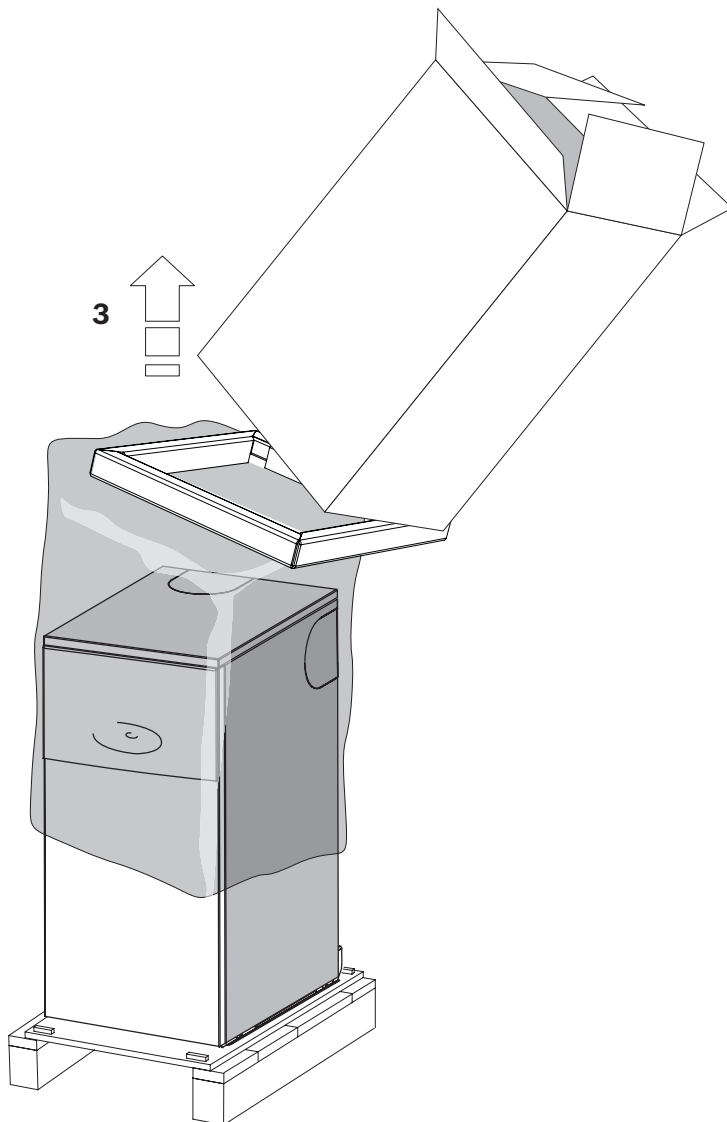
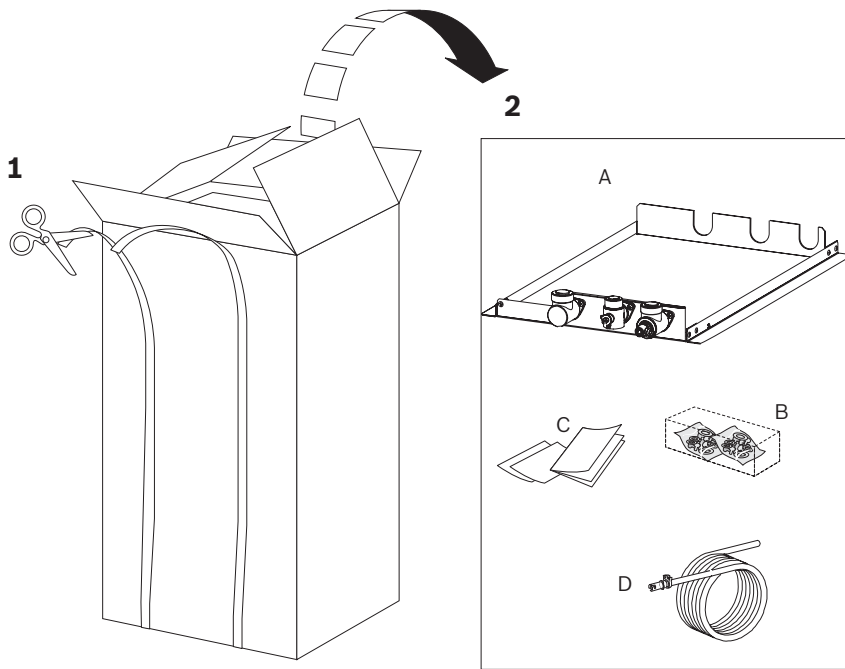

UNPACKING THE BOILER

Take care not to damage the boiler panels or the floor and note that the boiler may contain some water due to factory testing.

Unpacking:

- ▶ Undo the ties securing the carton to the pallet
If a sharp implement is used, care must be taken not to pierce the carton or cause injury.
- ▶ Before removing the carton it is advised that the top flaps are opened and items A, B, C and D are removed and set to one side.
- ▶ The carton can now be lifted off the boiler.
 - ▶ Remove the plastic bag protecting the boiler surfaces and place safely away from the working area.
 - ▶ Remove 2 screws at the rear of the board securing the board to the pallet.
 - ▶ Slide the boiler and board off the pallet.
 - ▶ The boiler is mounted on small wheels and it is recommended that two people are used to move the boiler from the board, taking care not to damage the panels or the floor.

At all times the correct method for handling heavy objects should be strictly observed.

GENERAL HANDLING GUIDELINES:

- ▶ Lift only a manageable weight, or ask for help.
- ▶ When lifting, bend the knees, and keep the back straight and feet apart.
- ▶ Do not lift and twist at the same time.
- ▶ Lift and carry items close to the body
- ▶ Wear protective clothing and gloves to protect from any sharp edges

A - Mounting frame

B - Installation pack

C - Literature pack

D - Condensate waste pipe & non-return valve

All dimensions in mm

MOUNTING FRAME FIXING & FLUE OPENING

CAUTION: Ensure there are no pipes, electric cables, damp proof course or other hazards before drilling.

SAFETY:

All relevant safety precautions must be undertaken. Protective clothing, footwear, gloves and safety goggles must be worn as appropriate.

MOUNTING FRAME/PIPEWORK POSITIONS:

- A - Mounting frame.
- B - Manifold connections.
- C - Mounting frame fixing point.
- D - Wall.
- E - Gas and water pipework (not supplied).
- F - Boiler.

FIXING THE MOUNTING FRAME:

- ▶ Position the mounting frame (A) on the floor against the wall with manifold connections (B) facing away from the wall (D) ensuring there is enough space for the pipework (E).
- ▶ Allow the minimum space from each side of the frame (A) for the boiler overhang (F) and minimum service clearance, as shown.
- ▶ Ensure the mounting frame is level and mark fixing points (C).
- ▶ Secure mounting frame (A) to the floor using appropriate fixings (not supplied).
- ▶ Clear any debris from the site.

FLUE OPENING:

- ▶ Follow the diagram opposite to mark the centre of the flue (1, & 2) for rear opening, (2 & 3) for side opening or (1 & 4) for top opening.

Measurements shown include the minimum service clearances.

NOTE: All horizontal flue sections must rise away from the boiler by 52mm per meter to ensure that condensate flows back into the boiler for safe discharge via the condensate waste pipe.

- ▶ Cover the mounting frame manifold assembly (A) to protect the manifold connections.
- ▶ Make an opening (X or Z) through the wall using a core drill or similar at a size relative to the wall thickness as shown below:

Wall thickness	Flue opening 60/100mmØ	Flue opening 80/125mmØ
150 - 240mm	127mmØ	152mmØ
240 - 330mm	127mmØ	152mmØ
330 - 420mm	127mmØ	162mmØ
420 - 500mm	140mmØ	162mmØ

Where the flue terminal can only be fitted from inside the building, increase the opening to 150mmØ to allow the optional weather collar to fit through the opening for 60/100 flue.

- ▶ Clear away any debris.

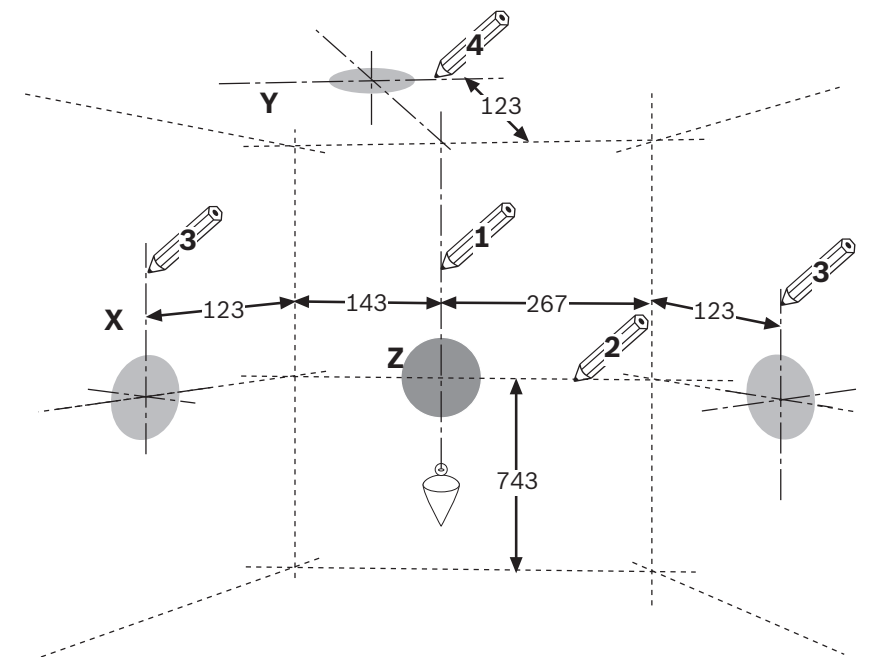
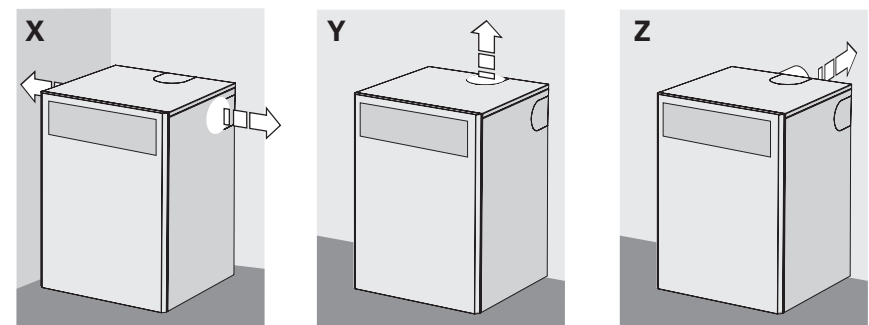
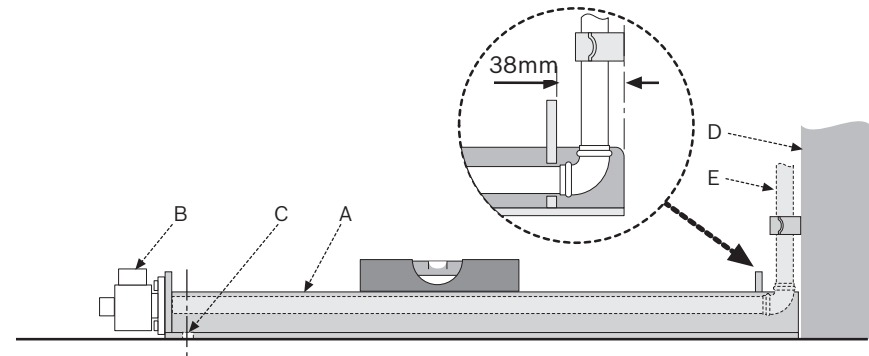
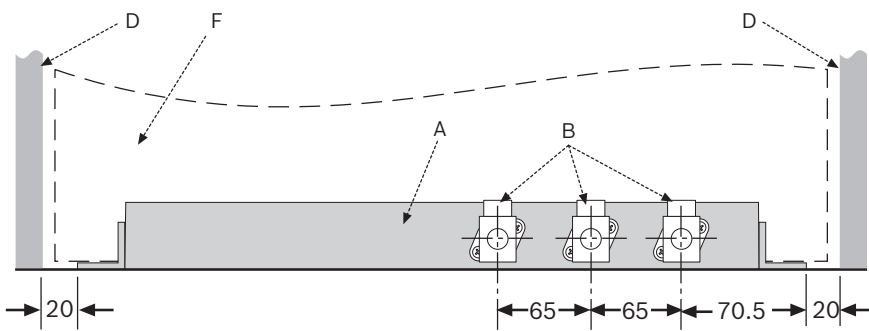

MOUNTING FRAME

CONNECTIONS

CAUTION: ISOLATE THE MAINS GAS SUPPLY BEFORE STARTING ANY WORK AND OBSERVE ALL RELEVANT SAFETY PRECAUTIONS.

GAS AND WATER CONNECTIONS:

- ▶ Ensure all pipework is clean and each pipe is in the correct position as shown opposite.
- ▶ Push in each pipe in turn and tighten the fitting to secure.

- A - CH flow (28mm)
- B - Gas inlet (22mm)
- C - CH return (28mm)
- D - Mounting frame.

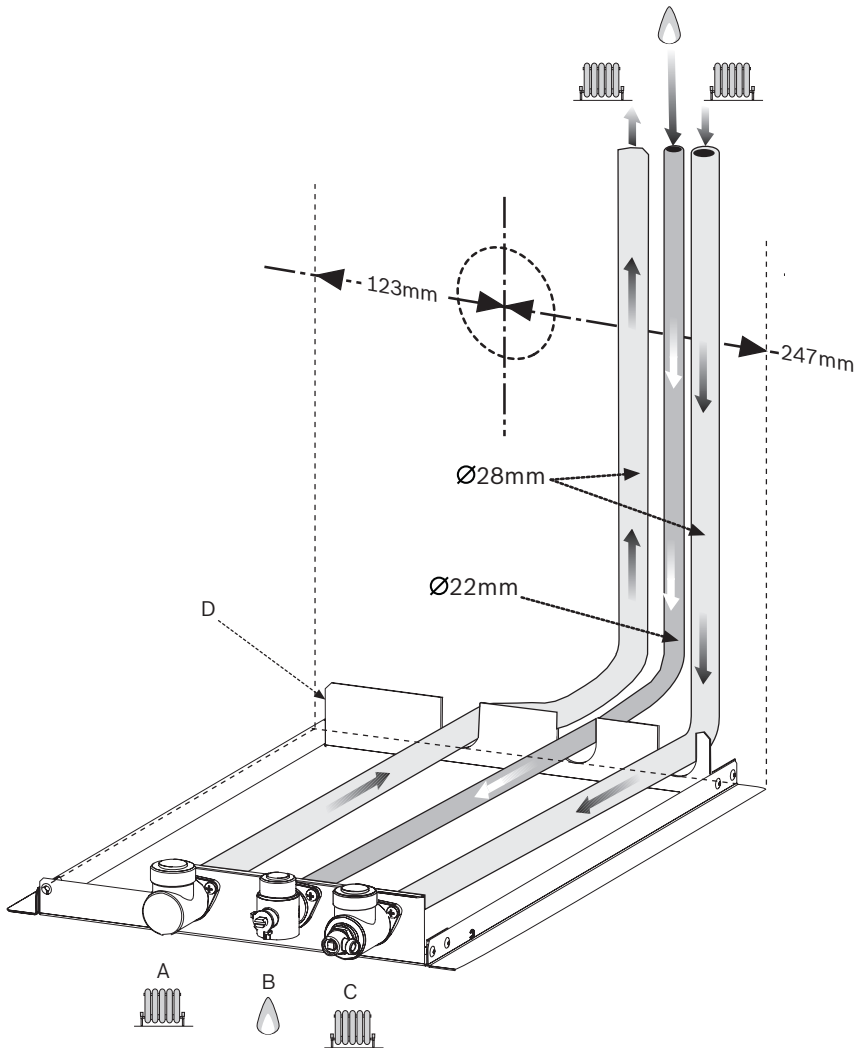

FLUE LENGTHS

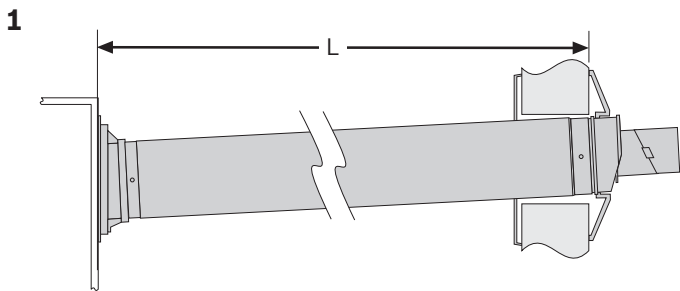

EFFECTIVE MAXIMUM STRAIGHT FLUE LENGTHS for Ø60/100mm Telescopic flue:

Appliance description	L max.
Greenstar FS 30CDi Regular	4000mm
Greenstar FS 42CDi Regular	4000mm

HORIZONTAL FLUE:

(60/100mm diameter)

For vertical flues and 80/125mmØ horizontal flues, please refer to separate Flue Kit instructions.

Ø60/100mm HORIZONTAL TELESCOPIC FLUE LENGTHS:

The maximum effective straight flue lengths (L) are stated opposite for the relevant appliance and must not be exceeded.

- Measure the total straight length (L) along the flue route, then add the following to length (L) to check the maximum flue length is not exceeded:

- ▶ 2000mm for each extra 90° bend.
- ▶ 1000mm for each extra 45° bend.

1500mm for each 90 bend
750mm for each 45 bend

All dimensions in mm.

1 Example with one extension tube:

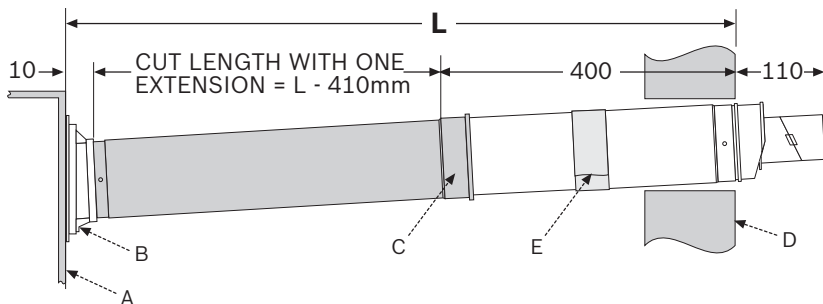

FLUE MEASURING & CUTTING

Do not exceed the maximum straight length for a horizontal Ø60/100mm flue or a Ø60mm plume management system (if used) as stated in this Instruction Manual or Flue Manual.

Cutting the flue to an exact measurement is not required as the telescopic flue terminal allows for adjustment.

- Measure the flue length (L) from the boiler inner case (A) along the flue route to the outside wall (D).

Note, the terminal end projects beyond the outside wall by the distance shown opposite.

- A - Boiler inner case.
- B - Flue connector.
- C - Flue extension tube socket.
- D - Outside wall.
- E - Aluminium tape over terminal screwed joint.

FLUE MEASURING & CUTTING

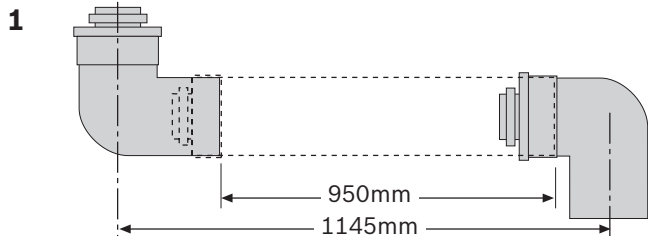

Flue bends:

- ▶ Connecting flue bends increases the effective pipe length and an allowance must be made for the different connectors. The example opposite shows dimensions for two 90° bends connected to a standard flue extension.

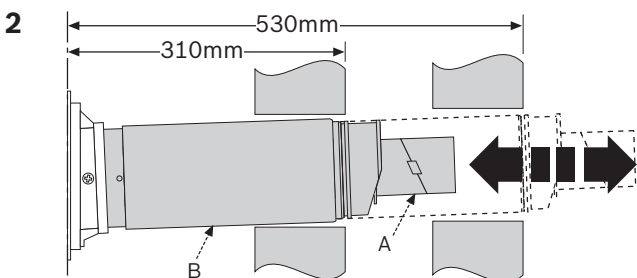

Adjusting the standard terminal length:

- ▶ Extend tube (A) by withdrawing from tube (B) to achieve the flue length required, 310- 530mm.
 - ▶ Secure with screw provided and seal joint with the aluminium tape supplied.

Reducing the standard terminal length:

- ▶ Remove securing screws (C) to detach the terminal assembly from the connector.
 - ▶ Slide terminal section (B) from the terminal assembly and discard.
 - ▶ To use terminal (A) without cutting remove the location lug (D) on the inner flue tube (E) and remove any burrs.

To reduce the terminal length further:

- ▶ Mark the length required for the terminal (A) as shown (min. 130mm) and cut square, taking care not to damage the tubes.
 - ▶ Remove any burrs and chamfer the outer edge of the tubes to assist ease of connection and prevent seal damage.

NOTE: The aluminium tape is not required when reducing the terminal.

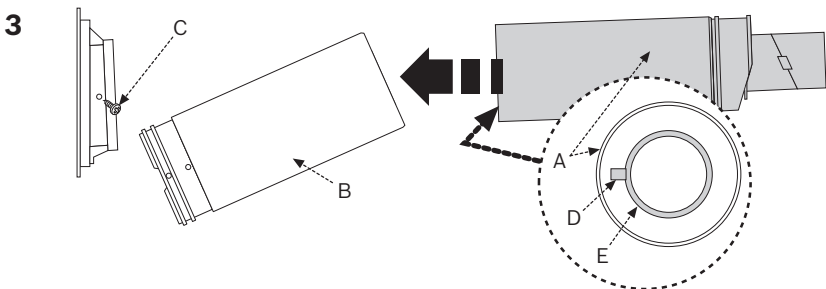

Reducing extended flue tube length:

Only cut flue extension & not flue terminal

- ▶ Mark flue extension (F) to the required distance measuring from the socket end and cut square taking care not to damage the tubes.
 - ▶ Remove any burrs and chamfer the outer edge of the tubes to assist ease of connection and prevent seal damage.

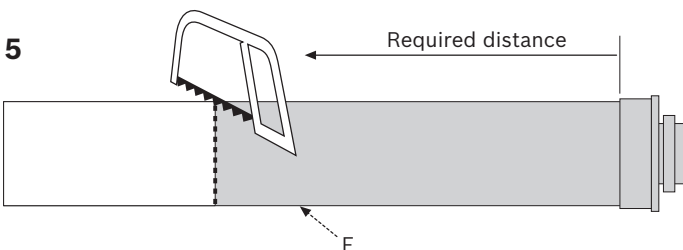
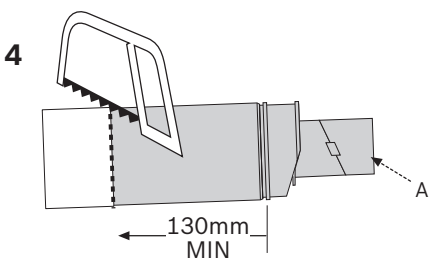

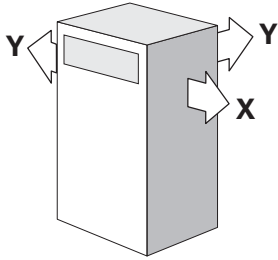

FLUE OUTLETS (X or Y):

- 1 ▶ Remove seal (B) from flue adaptor (A).
- 2 ▶ Cut square to mark, as shown, deburr and clean.
- 3 ▶ Replace seal (B).

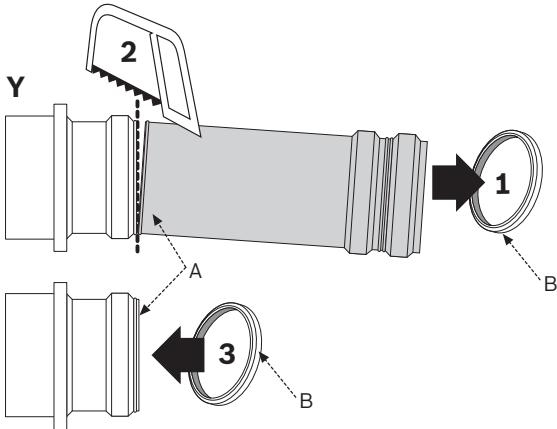
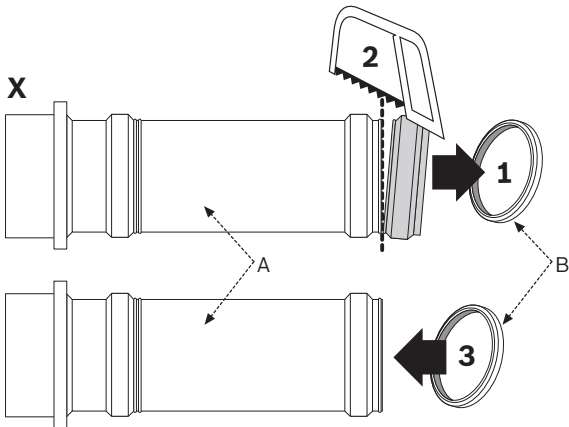

INSTALLATION

FLUE INSTALLATION

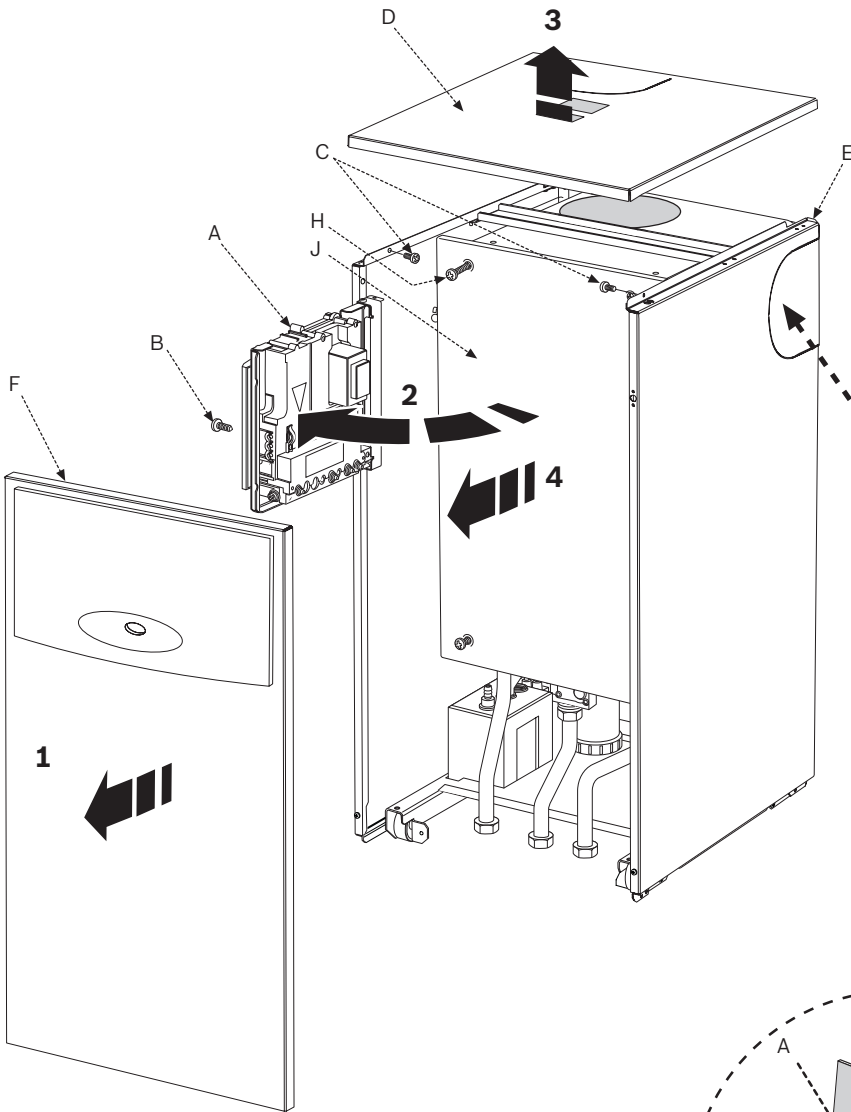

- 1 ▶ Grip the outer sides of the front panel (F) pull and lift away from retaining lugs.
- 2 ▶ Remove retaining screw (B) to swing control panel assembly (A) outwards to its full extent.
- 3 ▶ Remove screws (C) from inside of casing.
 - ▶ Lift front of top panel (D) to release.
 - ▶ Pull forwards to disengage rear retainer (E), then lift panel (D) away from boiler.
- 4 ▶ Release four screws (H) to remove the inner case cover (J).

INSTALLATION

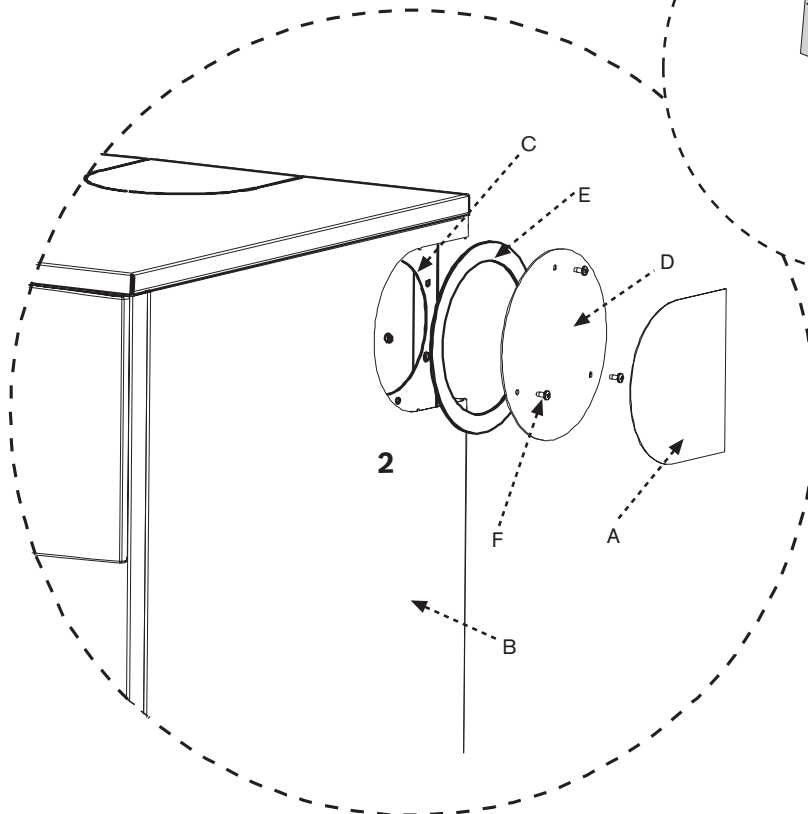

CONVERT FROM REAR FLUE OUTLET:

The boiler is supplied ready to fit a rear flue outlet. To flue from the sides or top of the boiler, follow the procedure below:

- 1 ▶ Remove the required side or top 'knock-out' panel (A) from the outer casing (B).
- 2 ▶ Remove the flue outlet blanking plate comprising: cover (D) and gasket (E) from the inner casing (C) by removing the three screws (F).
- 3 ▶ Refit the outlet blanking plate over the rear flue outlet.

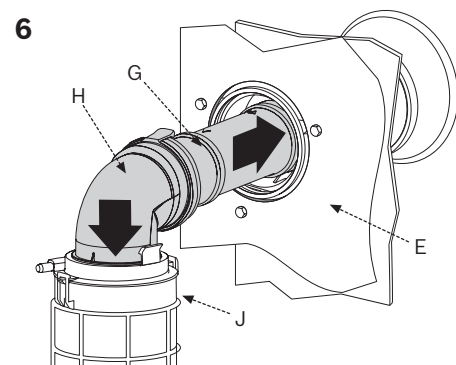
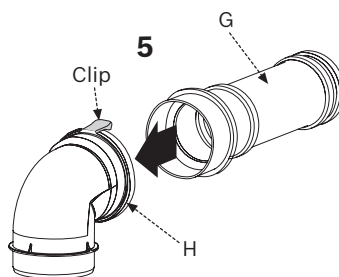
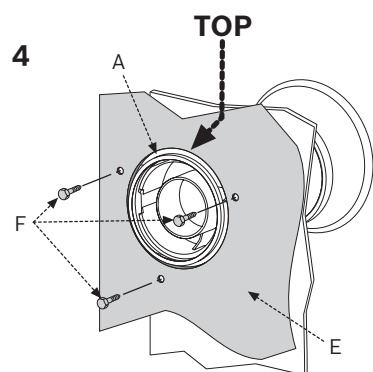
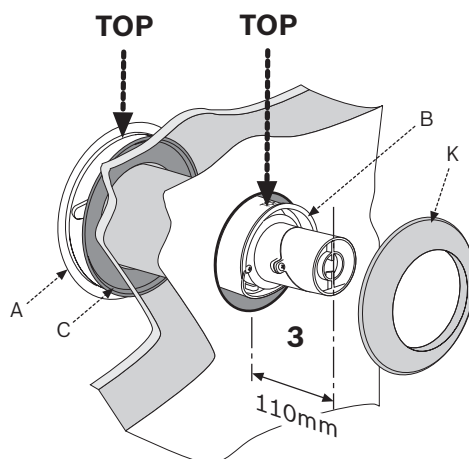
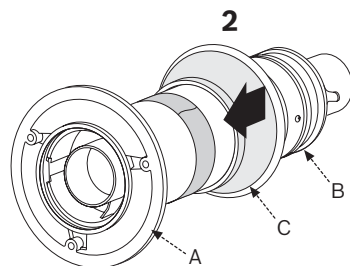
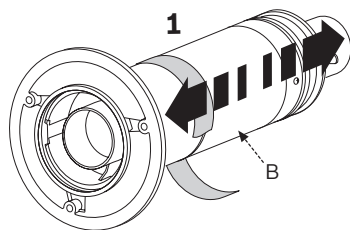

STANDARD FLUE INSTALLATION

NOTE: To ease assembly of the flue components, lightly grease seals lightly with the solvent-free grease supplied.

Check all the seals are seated properly in the grooves provided and are in good condition.

All flue joints must be sealed to prevent leakage of condensate and flue products.

Installing the standard flue:

- 1 ▶ Set the flue terminal (B) to the distance required, secure with screw and seal joint with the aluminium tape supplied.
- 2 ▶ Slide the inner wall seal (C) onto the terminal (B) as shown.
 - ▶ If fitting from inside the building; slide the outer wall seal (K) onto terminal (B).
- 3 ▶ Position terminal (B) through the flue opening in the wall to the outside and then pull back to create a seal.

▶ The flue terminal (B) MUST be fitted with the label marked 'TOP' uppermost to allow the correct fit and use of the plume management system.

- ▶ If fitting from the outside of the building; position terminal (B) through the flue opening of the building by the distance shown, slide the outer wall seal (K) onto terminal (B) to fit against the outer wall.
- 4 ▶ Roll the boiler into position on the floor mounting frame.
 - ▶ Position connector (A) with the label marked 'TOP' uppermost to align with the three holes in the boiler inner casing (E).
 - ▶ Secure using three hexagonal bolts (F).
- 5 ▶ Push-fit adaptor (G) into elbow (H) until secured by the clip.
- 6 ▶ Slide adaptor (G) into the inner flue tube of terminal (B) and push elbow (H) into flue outlet (J) until secured by the retaining clips ensuring a good seal is made.

FLUE TERMINAL PLUME MANAGEMENT

The flue discharge can be redirected allowing some plume management control, alternatively, a complete plume management system can be fitted to the flue terminal.

Redirecting the flue discharge:

Important: should you wish to use the plume deflector please use the additional grease enclosed to ensure that an adequate seal is retained.

- 1 ▶ Remove screws (A) and terminal end (B).
- 2 ▶ Spread the extra grease supplied into the groove that runs around the terminal outlet (C) to ensure a good seal is retained.
- 3 ▶ Rotate the detached end section (B) to plume deflecting position, as shown and refit using screws (A).
- 4 ▶ Loosen screws (D) and rotate the terminal end (B & C) to redirect the plume.

DO NOT rotate the complete flue terminal assembly.

- ▶ Tighten screws (D) to secure in the required position.

NOTE: The flue terminal outlet has built-in stops to limit rotation for the horizontal flue to allow condensate to run back into the boiler for safe disposal. Do not force beyond the limit stops.

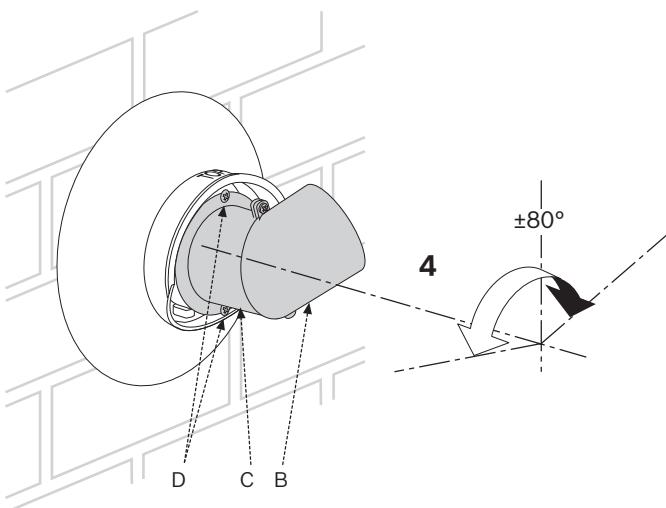
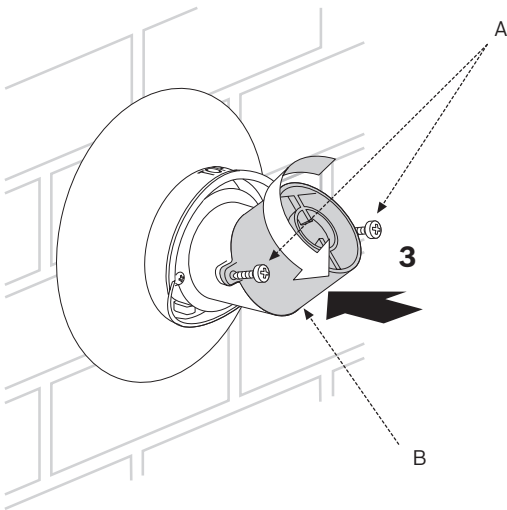
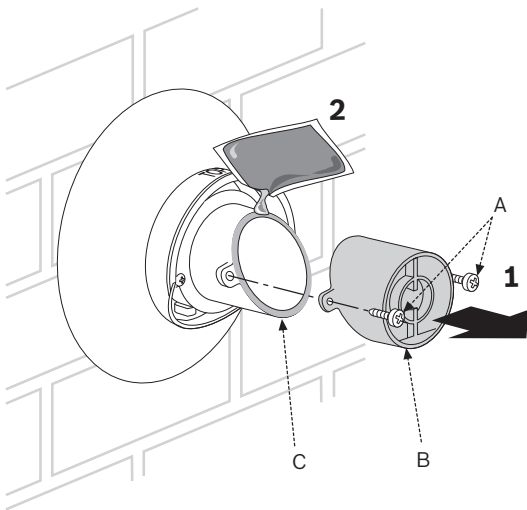

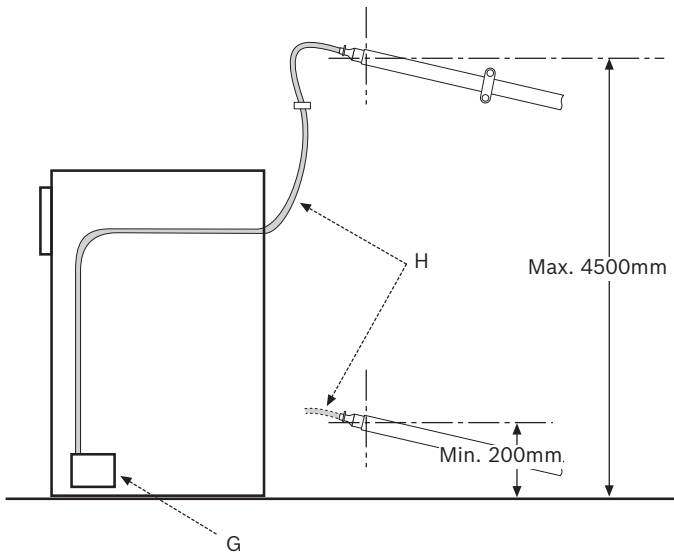

CONDENSATE, GAS & WATER CONNECTIONS

CONDENSATE CONNECTION:

The condensate pump (G) fills up and periodically discharges through the flexible condensate pipe (H) between 200mm to 4500mm from floor level. After this point the condensate flows, due to gravity, down the 21.5mm plastic pipe to the outlet.

- ▶ Fit the bayonet connector on end of the condensate waste pipe to the condensate pump, push down and rotate clockwise until the connector is locked.
- ▶ Route and secure condensate waste pipe (H) with clips supplied to prevent kinking or restriction.
- ▶ Cut off any excess pipe (H).
- ▶ Fit the condensate waste pipe (H) to adaptor (K) and secure with clip (J).
- ▶ Connect adaptor (K) to 21.5mm plastic pipe and terminate into an internal waste trap.

(See Pre-Installation section for condensate pipework running from the adaptor (K) to the discharge outlet).

Never terminate or discharge into any open source, including; sink, bath, shower, bidet, toilet etc.

Note: Any external condensate pipework should be protected with weather resistant insulation to help prevent freezing.

The flexible pipe supplied can only be used inside the property.

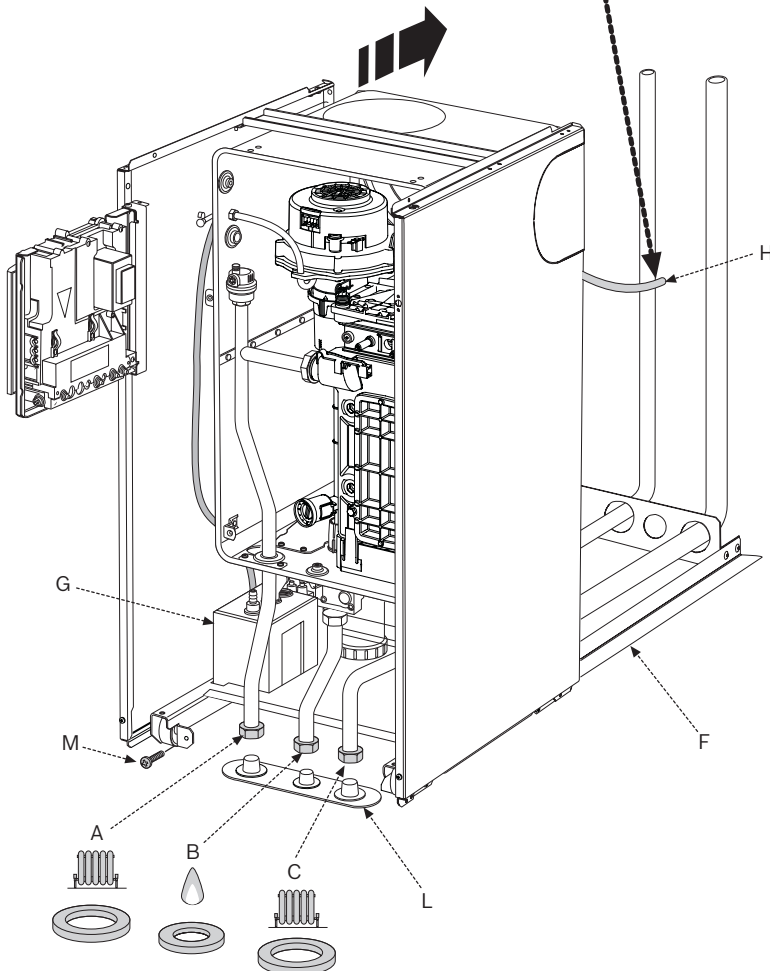
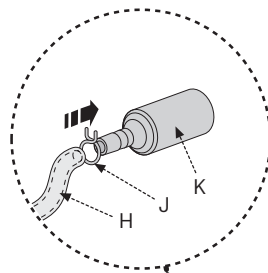

CAUTION: ISOLATE THE MAINS SUPPLIES BEFORE STARTING ANY WORK AND OBSERVE ALL RELEVANT SAFETY PRECAUTIONS.

GAS AND WATER CONNECTIONS:

- ▶ Remove the transit bungs (L) from the gas and water connections (A, B & C) on the boiler and mounting frame.

Note: Surplus water may be present due to factory testing.

- ▶ Ensure the area is clear of debris and manoeuvre the boiler rear wheels onto the outer rails of the mounting frame (F).
- ▶ Take care when moving the boiler to position the front wheels onto the rails and align the gas/water connections and the flue.
- ▶ Secure boiler to mounting frame (F) with screw (M)
- ▶ Place the 2 larger valve sealing washers (shown shaded) onto valves A & C.
- ▶ Place the smaller valve sealing washer onto valve B.
- ▶ Ensure all pipework is clean.
- ▶ Tighten the compression fittings to secure:
 - A - CH flow (28mm).
 - B - Gas inlet (22mm).
 - C - CH return (28mm).

CAUTION: ISOLATE THE MAINS ELECTRICITY SUPPLY BEFORE STARTING ANY WORK AND OBSERVE ALL RELEVANT SAFETY PRECAUTIONS

Note:

The mains electrical supply to the boiler and system wiring centre must be common and through either a common fused double pole isolator or a fused three pin plug and unswitched socket.

The isolator shall be situated next to the boiler for new systems and, where practicable, replacement boilers.

The isolator must have a contact separation of 3mm minimum between all poles. Any system connected to the boiler must not have a separate electrical supply.

External fuse 3 Amps.

When stripping wires ensure copper strands do not fall into the control box.

Access to electrical connections:

Remove boiler casing to access control panel.

1 Remove screw (A) and swing the control panel into the service position.

2 Remove the three screws (B) in the control panel and remove the connections cover.

3 Unclip cable clamp (C).

4 Cut off the tapered cable entry to suit the cable diameter.

5 Unscrew cable retaining screw (D).

Run the cable through the cable clamp (C) ensuring there is ample cable to reach the connectors.

6 Tighten the cable retaining screw D to secure the cable and replace clamp C into the control panel.

7 Mains power 230 Volt connection ST10:

▶ Separate wires from cable end and strip to 6mm

▶ Connect LIVE wire to terminal L

▶ Connect NEUTRAL wire to terminal N

▶ Connect EARTH wire to connector

NOTE: Make the EARTH wire longer so that if the cable is snagged, the EARTH wire is the last to be pulled out.

8 System wiring centre connection ST10:

▶ Remove link

▶ Connect LIVE wire to terminal Ls

▶ Connect NEUTRAL wire to terminal Ns

▶ Connect SWITCHED LIVE to terminal Lr

9 External pump must be wired back to the boiler:

▶ Connect pump LIVE to terminal Lz

▶ Connect pump NEUTRAL to terminal Nz

10 Refit all panels

NOTES: External diverter valve(s) and all other 230V parts are not supplied with the boiler.

Refer to manufacturers instructions when connecting external parts to the wiring centre.

Worchester, Bosch Group cannot be held responsible for wiring errors.

INSTALLATION

1

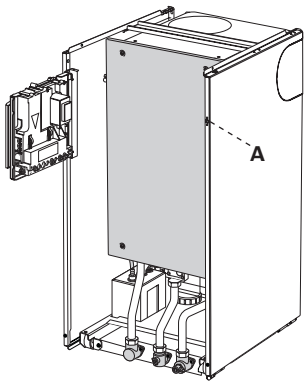

2

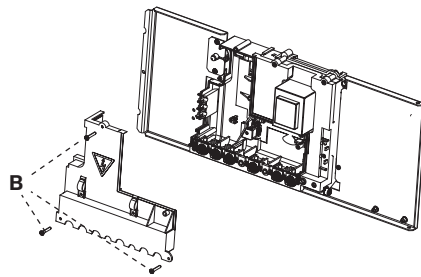

3

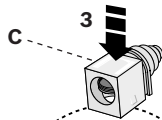

4

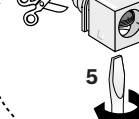

5

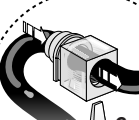

6

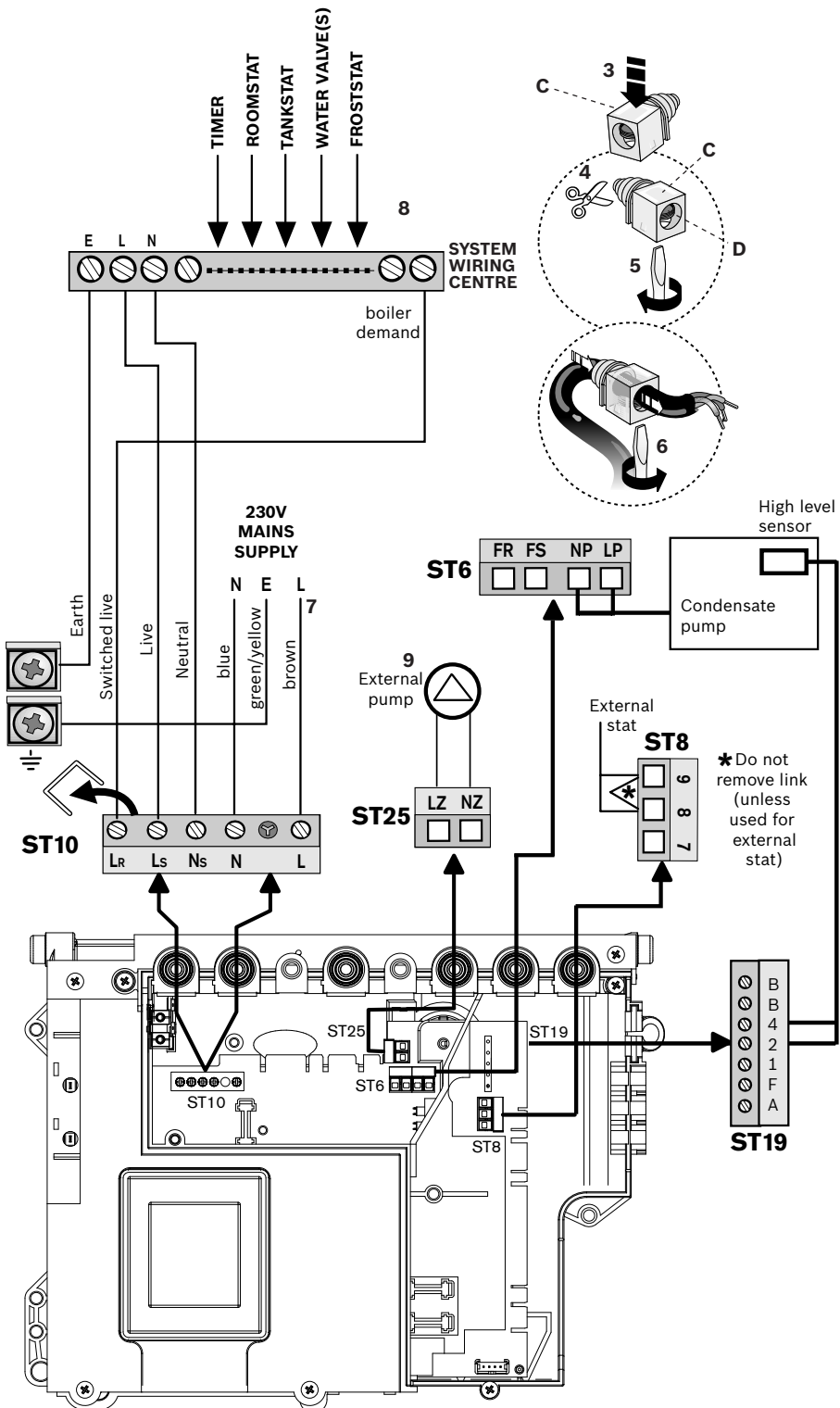
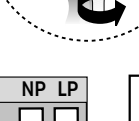

CAUTION: ISOLATE THE MAINS SUPPLIES BEFORE STARTING ANY WORK AND OBSERVE ALL RELEVANT SAFETY PRECAUTIONS.

COMMISSIONING

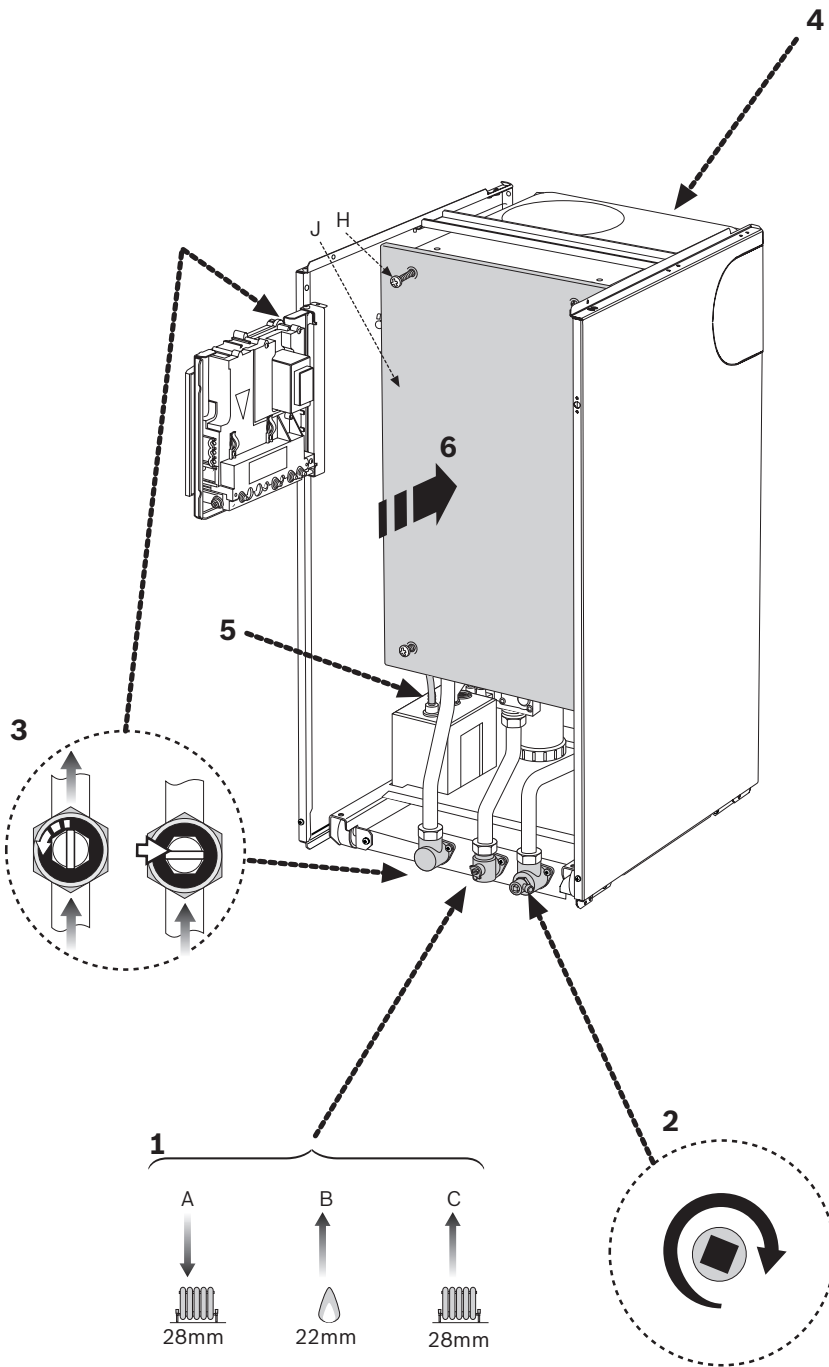

- 1 ▶ Check that the service and water pipes are connected to the correct valve on the manifold;
 - A - CH flow (28mm)
 - B - Gas inlet (22mm)
 - C - CH return (28mm)
- 2 ▶ Check all system and boiler drain points are closed.
- 3 ▶ Check the gas type specified on the identification plate matches that of the gas supply.
 - ▶ Turn on the main gas supply and purge the gas supply to the boiler ensuring that the room is well ventilated.
 - ▶ Test the gas supply for tightness as described in BS 6891.
- 4 ▶ Check the flue is correctly fitted and the connections are secure.
- 5 ▶ Check the condensate pipework is correctly fitted and connected.
- 6 ▶ Refit inner case cover (J) and secure with four screws (H).

IMPORTANT: If the boiler is not to be commissioned immediately then: after successfully completing all of the checks and any rectification work, shut off the gas supply and electrically isolate the boiler. Complete the installation part of the Guarantee Registration Card.

FILLING THE SYSTEM

- 1 ▶ Open all system and radiator valves.
 - ▶ Turn on the water main stop cock.
- 2 ▶ Open vented systems only;
 - ▶ Turn on the water to the system header tank and allow the system to fill.
- 3 ▶ Pressure gauge located externally on the system;
 - ▶ Fill the system to 1 bar pressure via a WRAS approved filling link.
- 4 ▶ Vent all radiators, retighten when completed.
 - ▶ Check the system and rectify any leaks.

STARTING THE APPLIANCE

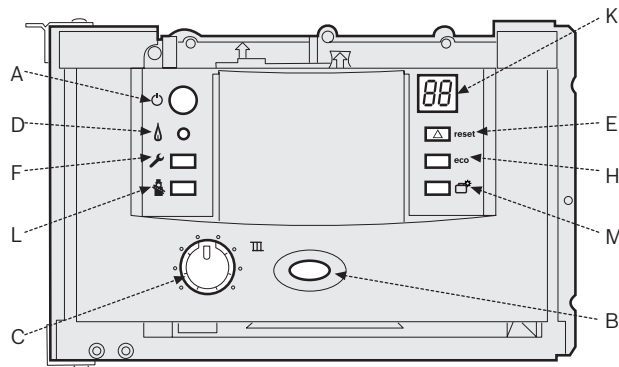

- A - MASTER SWITCH FOR ON/OFF
- B - MAINS ON/OFF INDICATOR + FAULT DIAGNOSTIC LIGHT (BLUE)
- C - TEMPERATURE CONTROL
- D - BURNER ON INDICATOR LIGHT (GREEN)
- E - FAULT RESET BUTTON
- F - SERVICE BUTTON
- H - NOT USED
- K - DISPLAY
- L - BOOST BUTTON (SERVICE ONLY)
- M - NOT USED

IMPORTANT: Never run the appliance when the appliance or system is empty or unpressurised.

Switching the appliance on/off:

- 1 ▶ Turn on mains power supply.
 - ▶ Turn on any external controls.
 - ▶ Set the thermostatic radiator controls to maximum.
 - ▶ Set the clock/programmer to continuously ON and the room thermostat to maximum temperature.
- 2 ▶ Press button (A) and the power on indicator (B) illuminates blue.
- 3 ▶ Turn the temperature control (C) to maximum. The burner on indicator (D) illuminates green when the burner has lit.

NOTE: The boiler runs for 15 minutes at minimum heating output to fill the condensate trap. This occurs every time the mains supply has been interrupted.

- 4 ▶ If the boiler fails to light, the blue power indicator (B) and reset button (E) will flash alternately.
 - ▶ To reset the boiler, press and hold the reset button (E) for 2 seconds.

CAUTION: DO NOT PRESS THE POWER INDICATOR (B) TO RESET THE BOILER.

THE COMBUSTION FOR THE APPLIANCE IS FACTORY SET.

NO ADJUSTMENT IS REQUIRED IF THE GAS INLET PRESSURE IS CORRECT.

CHECKING THE GAS INLET PRESSURE:

The inlet pressure to the appliance must be checked using the following procedure:

SETTING THE BOILER TO MAXIMUM:

- ▶ Press boost button for ten seconds and set temperature to maximum.

The boost button will illuminate continually.

MEASURING THE INLET PRESSURE:

- ▶ Slacken the screw in the inlet pressure test point and connect a manometer.
- ▶ Measure the pressure with the boiler running at maximum.
- ▶ Check the gas supply working pressure at the gas valve inlet point:

N.G. 17 - 19 mbar (18 mbar nominal)

L.P.G. 35 - 39 mbar (37 mbar nominal)

▶ The gas rate should be measured at the gas meter after 10 minutes operation at maximum. See Technical Data section at the front of this manual.

(LPG) Where a gas meter is NOT available the CO/CO₂ must be checked to the units shown in "Setting air/gas ratio"

▶ Ensure inlet pressure is satisfactory with all other gas appliances working.

▶ Replace controls cover.

NOTE: This boiler is designed with a differential of 20°C across the heating system.

IMPORTANT: Do not continue commissioning until the correct gas inlet pressure is achieved.

▶ If pressure is satisfactory press the boost button again and the boiler will return to normal operation.

If left in service mode the control will return to normal operation after 15 minutes.

▶ Reseal the screw in the gas inlet pressure test point.

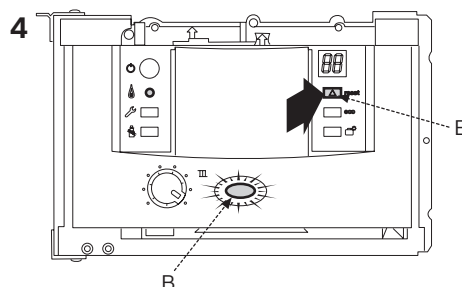
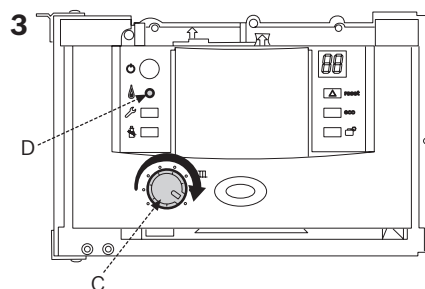
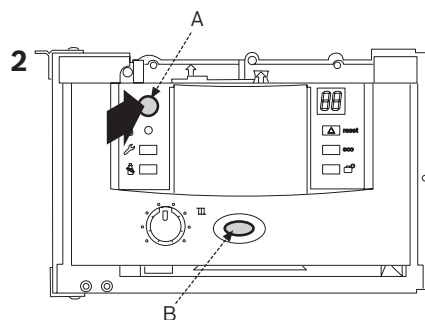
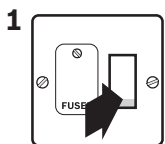

IMPORTANT: Debris from the system can damage the boiler and reduce efficiency. Failure to comply with the guidelines for the use of water treatment with the appliance will invalidate the appliance warranty.

FLUSHING (Central Heating):

- ▶ Switch off the boiler.
- ▶ Open vented systems only: turn off the water to the system header tank.
- ▶ Open all radiator valves/drain cocks and drain the system while the appliance is hot.
- ▶ Close drain cocks.
- ▶ Add a suitable flushing agent and refill the system at the correct strength for the system condition in accordance with the manufacturer's instructions.
- ▶ Run the boiler/system at normal operating temperature for the time stated by the flushing agent manufacturer.
- ▶ Drain and thoroughly flush the system to remove the flushing agent and debris.

INHIBITOR (Central Heating):

- ▶ Check drain cocks are closed and all radiator valves are open.
- ▶ Add a suitable* inhibitor, (or combined inhibitor/anti-freeze if the system is exposed to freezing conditions) to the heating system in accordance with the manufacturers instructions.
The inhibitor or combined inhibitor/anti-freeze must not cause damage to the materials within the boiler (aluminium, stainless steel, copper and brass) and any other materials/components within the system.
- ▶ Open vented systems only: turn on the water to the system header tank and allow the system to fill.
- ▶ Sealed systems only: fill the system to between 1 and 2 bar via a WRAS approved filling loop.
- ▶ Vent the boiler and all radiators; retighten vents when complete.
- ▶ Record the date when the inhibitor was added to the system on the guarantee card.

NOTE:

The concentration level of inhibitor in the system should be checked every 12 months or sooner if system content is lost.

The addition of sealing agents to the system water is not recommended as this can cause problems with deposits left in the heat exchanger.

*** compatible with aluminium. The pH value of the system water must be less than 8 or the appliance guarantee will be invalidated.**

NOTE:

At the time of commissioning, complete all relevant sections of the Benchmark Checklist located on the inside back pages of this document.

- 1 ▶ Engage top panel (D) onto rear retainers (E) and lower front of panel into position.
▶ Secure with screws (C).
- 2 ▶ Swing control panel assembly (A) into the boiler.
▶ Secure with screw (B).
- 3 ▶ Locate bottom corners of the front panel (F) into retainers (G).
▶ Push top of front panel to engage clips (H).

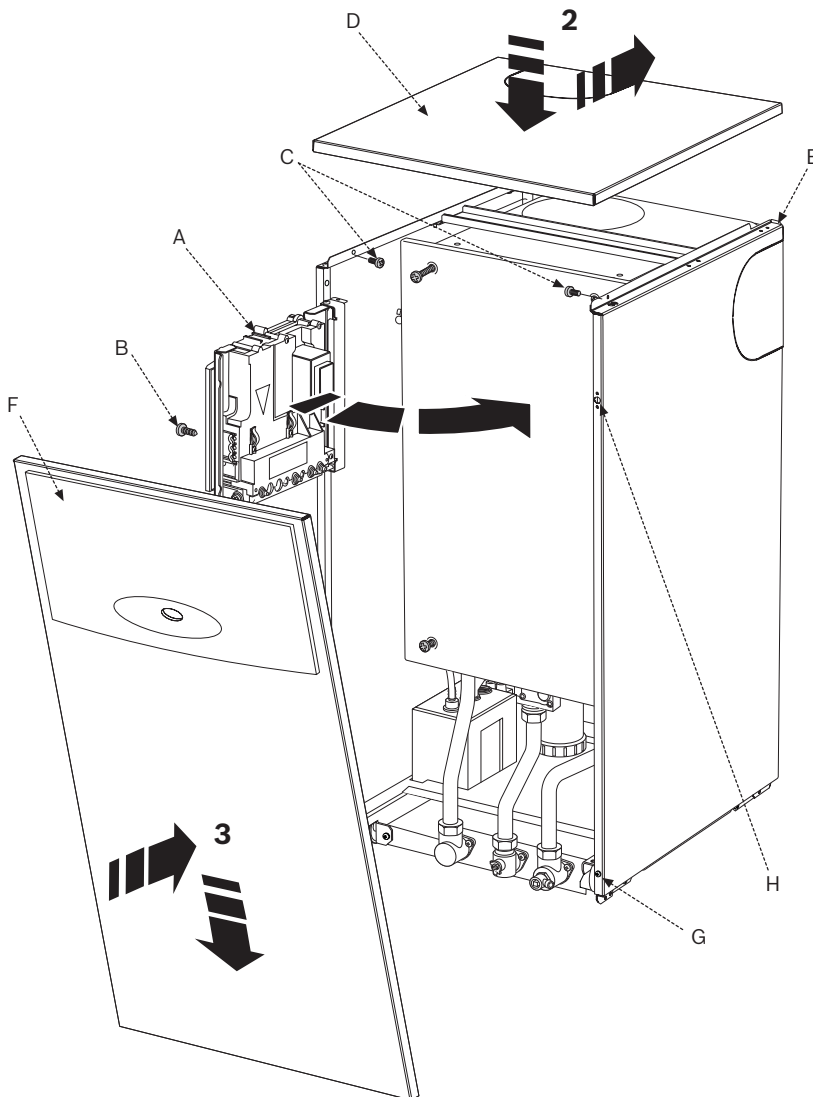

HANDOVER:

- ▶ Complete the Benchmark log book at the rear of the manual.
- ▶ Set up the controls and show the user how to operate all the controls shown in the User Guide.
- ▶ If the appliance is unused and exposed to freezing conditions, advise the customer of the precautions necessary to prevent damage to the boiler, system and building.
In the event of the appliance being inoperative, isolate the boiler and drain the system and boiler.

CAUTION: TURN OFF THE GAS SUPPLY AND ISOLATE THE MAINS SUPPLIES BEFORE STARTING ANY WORK AND OBSERVE ALL RELEVANT SAFETY PRECAUTIONS

IMPORTANT: AFTER REPLACEMENT OF ANY COMPONENTS ALWAYS CHECK FOR GAS TIGHTNESS WHERE RELEVANT AND CARRY OUT FUNCTIONAL CHECKS AS DESCRIBED IN COMMISSIONING. ANY O-RING OR GASKET THAT APPEARS DAMAGED MUST BE REPLACED.

INSPECTION & SERVICE

IMPORTANT: Any service work must be carried out by competent registered engineers, such as British Gas or other GAS SAFE registered personnel.

NOTE: After servicing, complete the relevant Service Interval Record section of the Benchmark Checklist located on the inside back pages of this document.

NOTE: A service must NOT be attempted if a CO/CO₂ analyser is NOT available.

- To ensure the continued efficient operation of the appliance it must be checked at regular intervals.
- The frequency of servicing will depend upon the particular installation conditions and usage however, an annual service is recommended.
- The extent of the service required by the appliance is determined by the operating condition of the appliance when tested by fully qualified engineers.

SERVICE FUNCTION:

Setting boiler to maximum:

- ▶ Press and HOLD central heating boost button (L) for 10 seconds and set Central Heating temperature to maximum.

The central heating boost button will illuminate continually.

The boiler will stay in this mode for 15 minutes unless the central heating boost button is pressed again.

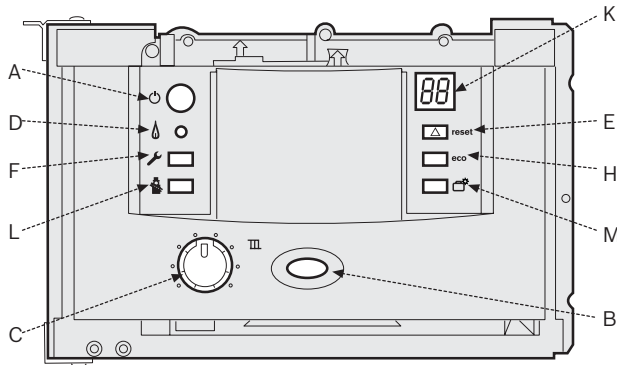

- A - MASTER SWITCH FOR ON/OFF
- B - MAINS ON/OFF INDICATOR + FAULT DIAGNOSTIC LIGHT (BLUE)
- C - TEMPERATURE CONTROL
- D - BURNER ON INDICATOR LIGHT (GREEN)
- E - FAULT RESET BUTTON
- F - SERVICE BUTTON
- H - NOT USED
- K - DISPLAY
- L - BOOST BUTTON (SERVICE ONLY)
- M - NOT USED

SERVICE INSPECTION:

- 1 ▶ Grip the outer sides of the front panel (F) pull and lift away from retaining lugs.
 - 2 ▶ Remove retaining screw (B) to swing control panel assembly (A) outwards to its full extent.
 - 3 ▶ Release four screws (H) to remove the inner case cover (J).
- ▶ Connect a manometer to the fan pressure test point, (see step 1 in the figure on next page).
 - ▶ After measurement replace test point cover.
- Pressure readings will be negative, refer to chart below.

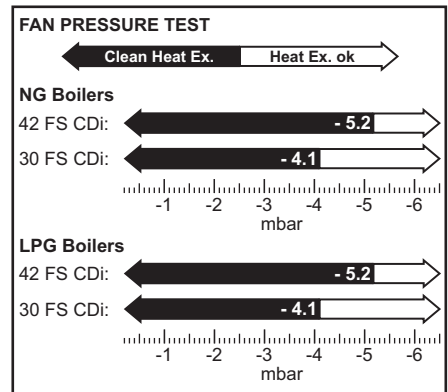
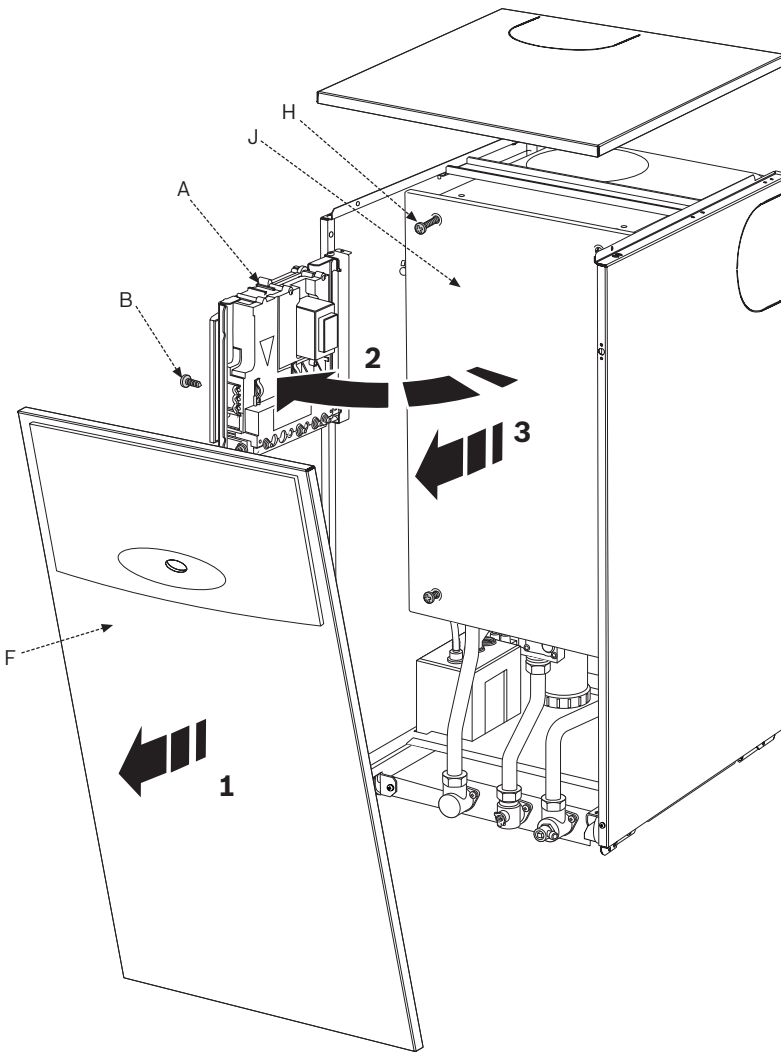

Pressure readings in the black area indicate that the heat exchanger requires cleaning.

- ▶ Check that the terminal and terminal guard, if fitted, are clear and undamaged.
- ▶ If the appliance is in a compartment or cupboard check that the specified service space around the appliance is clear.
See 'Boiler Location & Clearances' under the Pre-Installation section for compartment clearances.
- ▶ Check all the joints and connections in the system and remake any that show signs of leakage. Refill and re-pressurise the system.
See 'Filling the System' and 'Water Treatment' under the Commissioning section.
- ▶ Operate the appliance and take note of any irregularities. Call up the last fault stored by the Bosch Heatronic, Service Function '6A'.
Refer to 'Fault Finding' under the Fault Finding & Diagrams section for display codes and rectification procedures.

IMPORTANT: AFTER COMPLETING THE APPLIANCE SERVICE THE CO/CO₂ MUST BE CHECKED AND SET TO THE LIMITS IN THE SECTION "AIR/GAS RATIO".

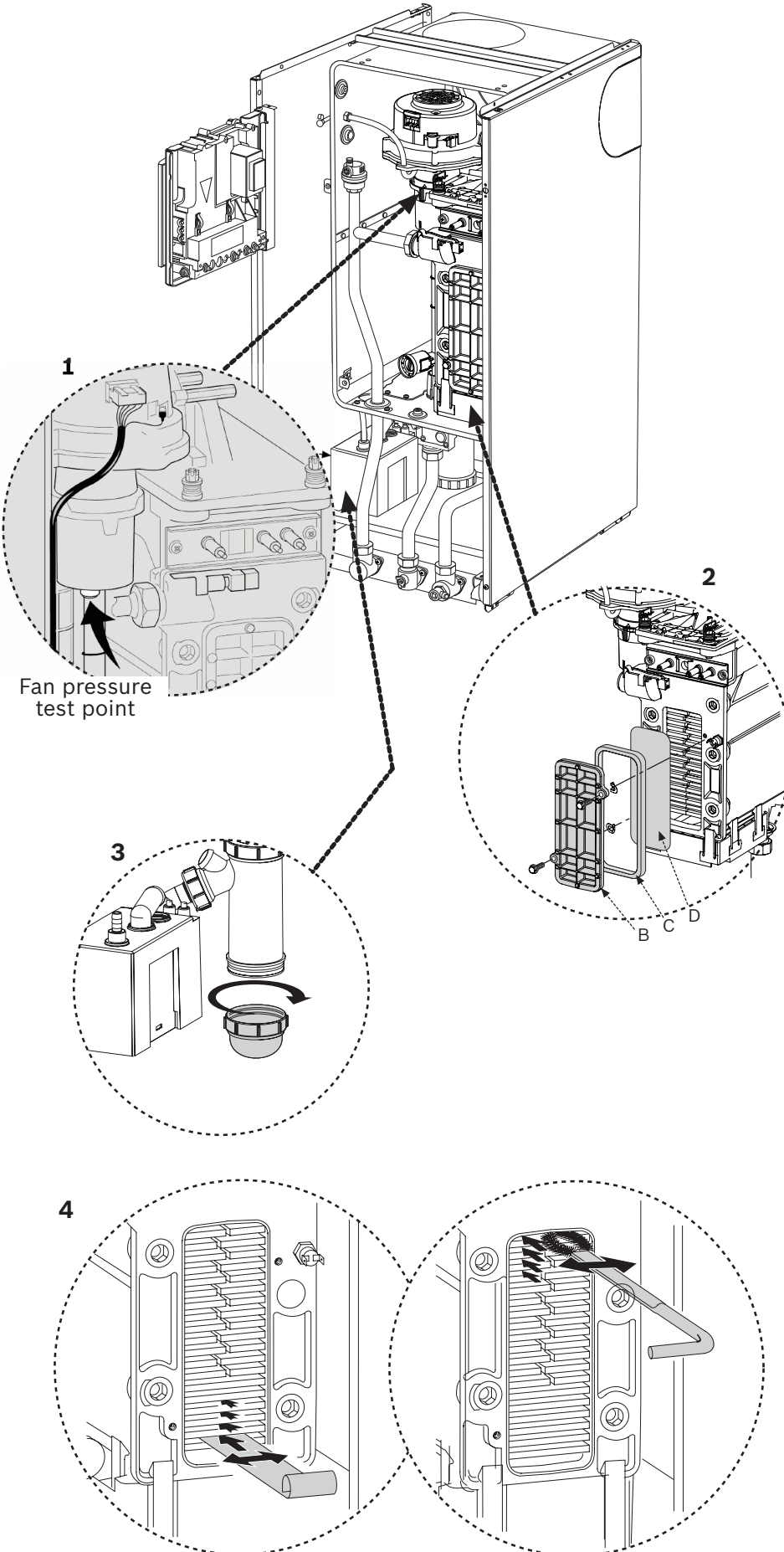

If the Heat Exchanger requires cleaning:

An accessory kit is available (No. 840) specifically designed for cleaning the heat exchanger. If required order 7 719 001 996.

- 2 ▶ Remove the cleaning access cover (B), seal (C) and metal plate (D) securing it, if present.
- 3 ▶ Unscrew the condensation trap cap and place a suitable container underneath.

NOTE: Use a new seal when reassembling.

- 4 ▶ Loosen any deposits in the heat exchanger from top to bottom using the cleaning blade.
- ▶ Clean the heat exchanger from top to bottom using the brush.
- ▶ Refit the "clean out" access cover in reverse order using a new seal (C), hand tighten screws and then use a spanner to tighten a further half turn.
- ▶ After re-assembly check CO/CO₂ levels as described in the section "Setting the air/gas ratio".

To Remove Condensate pump:

- ▶ Disengage condensate pipe from condensate pump.
- ▶ Remove condensate pump from base panel.
- ▶ After servicing the heat exchanger, fill the condensate trap with approximately 250 millilitres of water and refit in reverse order.

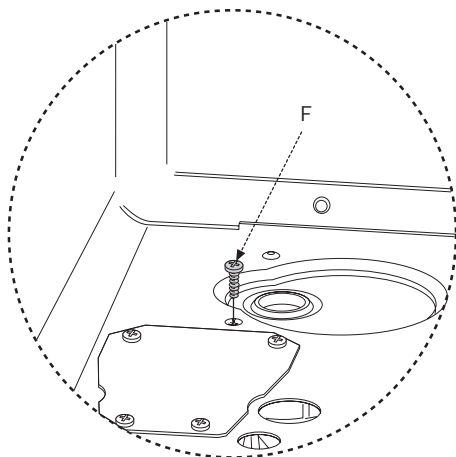
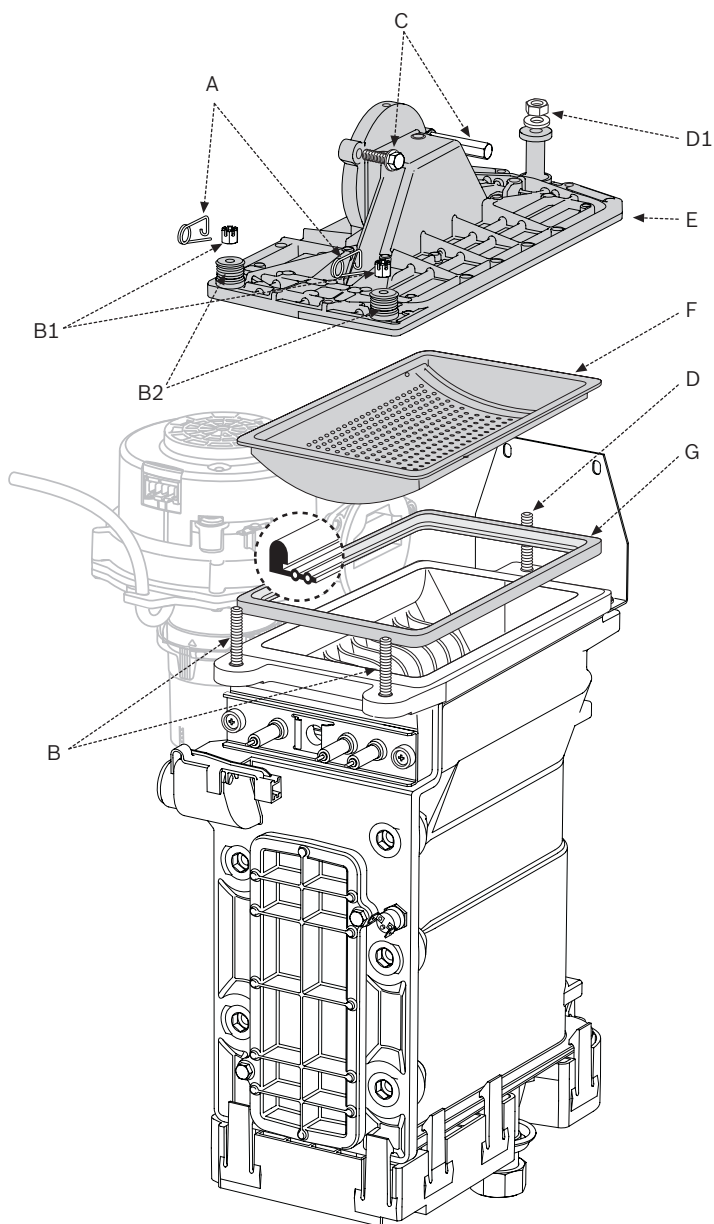
**Burner:**

- ▶ Check that the boiler is completely isolated from the gas supply.
- 1 ▶ Remove the clips (A), castellated nuts (B1) and springs (B2) from the studs (B).
 - ▶ Unscrew and remove the two hexagon headed screws (C) securing the fan.
 - ▶ Remove nut (D1) from the rear stud (D).
 - ▶ Remove the burner cover plate (E).
- 2 ▶ Remove the burner (F) and clean the components.

Do not use a wire brush.

- ▶ Re-assemble burner in reverse order using a new seal (G).
- ▶ After re-assembly check CO/CO₂ levels as described in the section "Setting the air/gas ratio"

For sealed systems only:**Max pressure:**

- ▶ When the heating system water is at maximum temperature, 2.65 bar must not be exceeded. If this pressure is exceeded then an extra expansion vessel must be fitted into the system return as close as possible to the appliance.
- ▶ If the system does not retain the pressure, the expansion vessel and the heating system should be checked for leaks.

Electrical wiring:

- ▶ Check the electrical wiring for physical damage and replace any damaged wires.

To check the flap valve in fan intake:

- ▶ Refer to page 38 for access to the fan intake.
- ▶ Carefully withdraw the flap valve from fan intake tube and check for soiling and splits, clean or replace as required.
- ▶ Take care when refitting the flap valve, the flaps must open upwards into the fan intake tube.
- ▶ After re-assembly check CO/CO₂ levels as described in the section "Setting the air/gas ratio"

To clean the condensate trap:

- ▶ Remove pipe from condensate pump.
- ▶ Remove screw retaining trap (F) and push trap downwards until clear.
- ▶ Remove trap from boiler along with pipe to condensate pump.

CAUTION: TURN OFF THE GAS SUPPLY AND ISOLATE THE MAINS ELECTRICAL SUPPLY BEFORE STARTING ANY WORK AND OBSERVE ALL RELEVANT SAFETY PRECAUTIONS. DRAIN THE BOILER/SYSTEM WHERE NECESSARY AND PROTECT ANY ELECTRICS FROM WATER INGRESS DURING COMPONENT REPLACEMENT.

IMPORTANT: Refit or replace any components removed from the appliance in the reverse order using new gaskets/'O' rings/sealant/heat transfer paste where necessary.

Any 'O' ring or gasket that appears damaged must be replaced. Always check that any electrical connections are correctly made and that all screws are tight.

AFTER REPLACEMENT OF ANY COMPONENTS ALWAYS CHECK FOR GAS TIGHTNESS WHERE RELEVANT AND CARRY OUT FUNCTIONAL CHECKS AS DESCRIBED IN THE COMMISSIONING SECTION.

REPLACEMENT PARTS

IMPORTANT: Any service work must be carried out by competent registered engineers, such as British Gas or other GAS SAFE registered personnel.

IMPORTANT: After re-assembly the combustion must be checked using the procedure in the section "Setting the air/gas ratio". Measurement and setting of the gas ratio must not be attempted unless the person is equipped with a combustion analyser conforming to BS 7927 and is competent in its use.

DRAINING THE APPLIANCE:

- ▶ Turn off the system heating flow and return stop cocks - external to boiler.
- ▶ Using a suitable hose, attach one end to the drain tap on the boiler return elbow and lead the other end of the hose to an external drain point.
- ▶ Fully open the drain tap on the boiler return elbow.
- ▶ Close the drain tap when the flow from the appliance has stopped and remove the hose.

NOTE:

A small quantity of water may remain in some components even after the appliance has been drained. Protect any electrical components when removing items from the water circuits.

PCB CONTROL BOARD & TRANSFORMER:

Access to boiler control components

- ▶ Remove screws (A) to release the cover from the controller.

PCB Fuse

- ▶ Remove the fuse (B) and replace with a spare that are clipped on the inside of the controller cover.

Transformer / PCB

- ▶ Disconnect all electrical connections from the control.
- ▶ Remove the screws (C) retaining the rear panel of the control and remove the panel.
- ▶ After re-assembly check CO/CO₂ levels as described in the section "Setting the air/gas ratio"

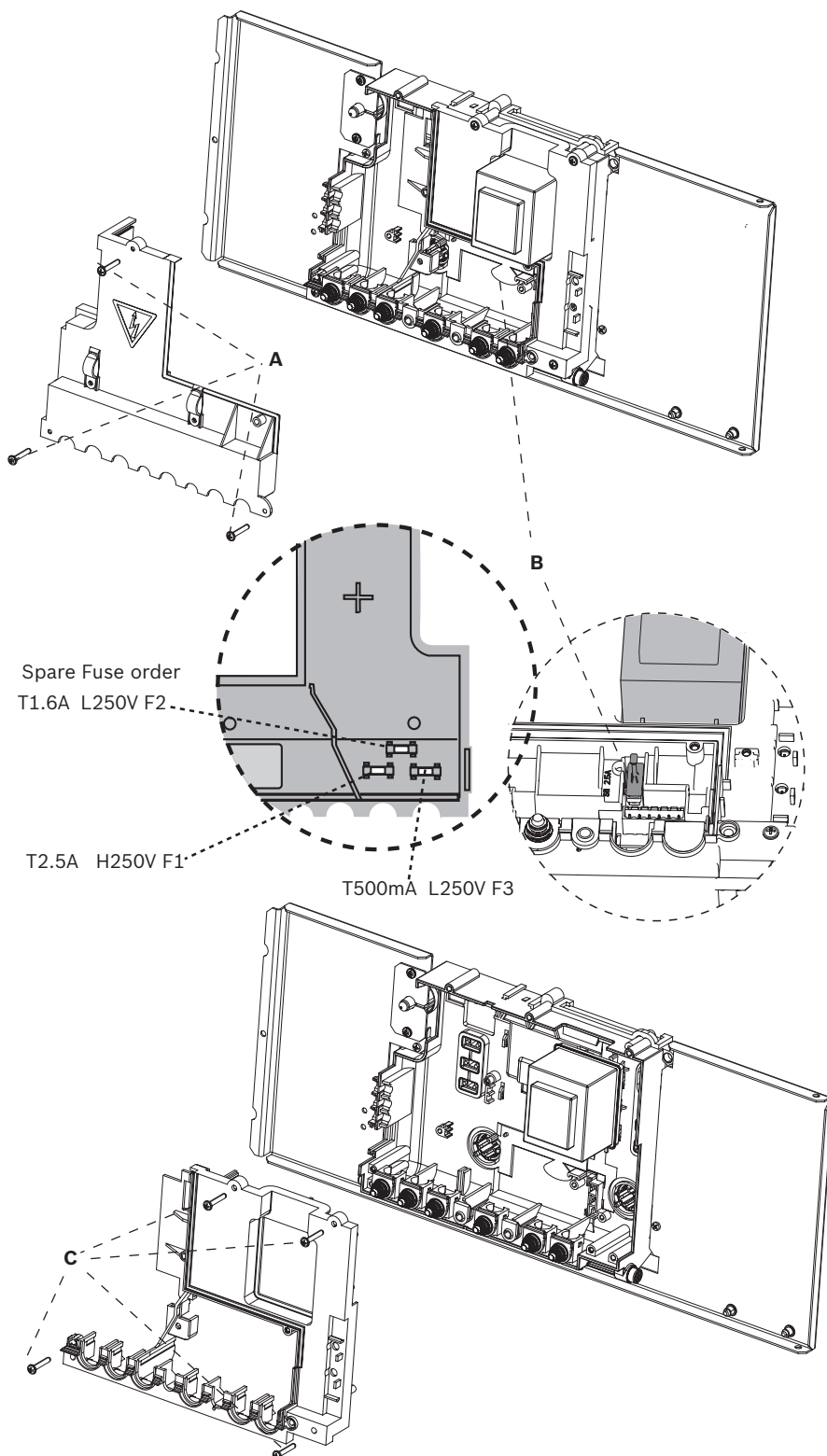

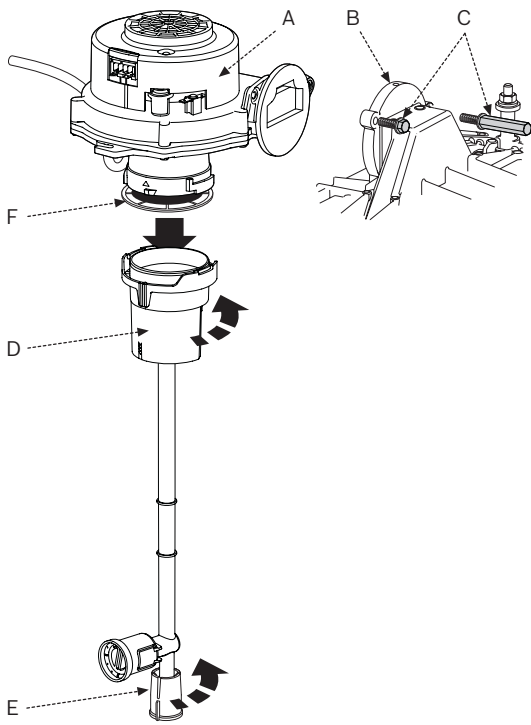

Fan Assembly:

- ▶ Undo lower pipe union on gas pipe (E).
- ▶ Remove fan lead and earth connector.
The earth connector has a positive clip fixing.
- ▶ Remove fixing screws (C) attaching fan (A) to the burner cover (B).
- ▶ Remove fan (A) with gas pipe (E) and mixer unit (D).
- ▶ Twist mixer unit (D) with gas pipe (E) to separate from fan (A).
- ▶ After reassembly, check CO/CO₂ levels as described in “Setting the air/gas ratio” section.

Flap Valve:

- ▶ Undo lower pipe union on gas pipe (E).
- ▶ Remove pipe (E) by pushing upwards and to the rear.
- ▶ Twist mixer unit (D) with gas pipe (E) to separate from fan (A).
- ▶ Remove flap valve (F) from within fan intake (A) and replace.

NOTE: Ensure the flap valve is fitted correctly with rubber flaps opening upwards.

- ▶ After reassembly, check CO/CO₂ levels as described in “Setting the air/gas ratio” section.

Condensate pump:

- ▶ Disconnect electrical connections in control box, see wiring schematic in the ‘Fault finding & Diagrams’ section..
- ▶ Remove 15mm flexible tube (H) from pump by rotating anti-clockwise and pulling up.
- ▶ Remove black flexible pipe (J) from condensate tank. Take care as there may be condensate remaining in the pipe.
- ▶ Carefully remove the condensate pump (G) from the boiler and pour any excess condensate into a suitable container for safe disposal.

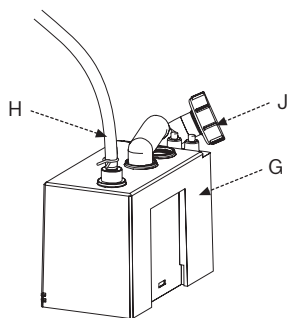

Sensors:

▶ Check that the appliance is electrically isolated.

Flow temperature sensor (A):

- ▶ Remove the connector.
- ▶ Release the sensor clip and withdraw the sensor.
- ▶ Apply heat transfer paste to the replacement sensor.

Safety temperature limiter (B):

- ▶ Remove the connectors.
- ▶ Unscrew the sensor.

Flue Gas sampling point (C):

Flue Temperature limiter (H):

- ▶ Remove the connector.
- ▶ Unscrew the sensor.

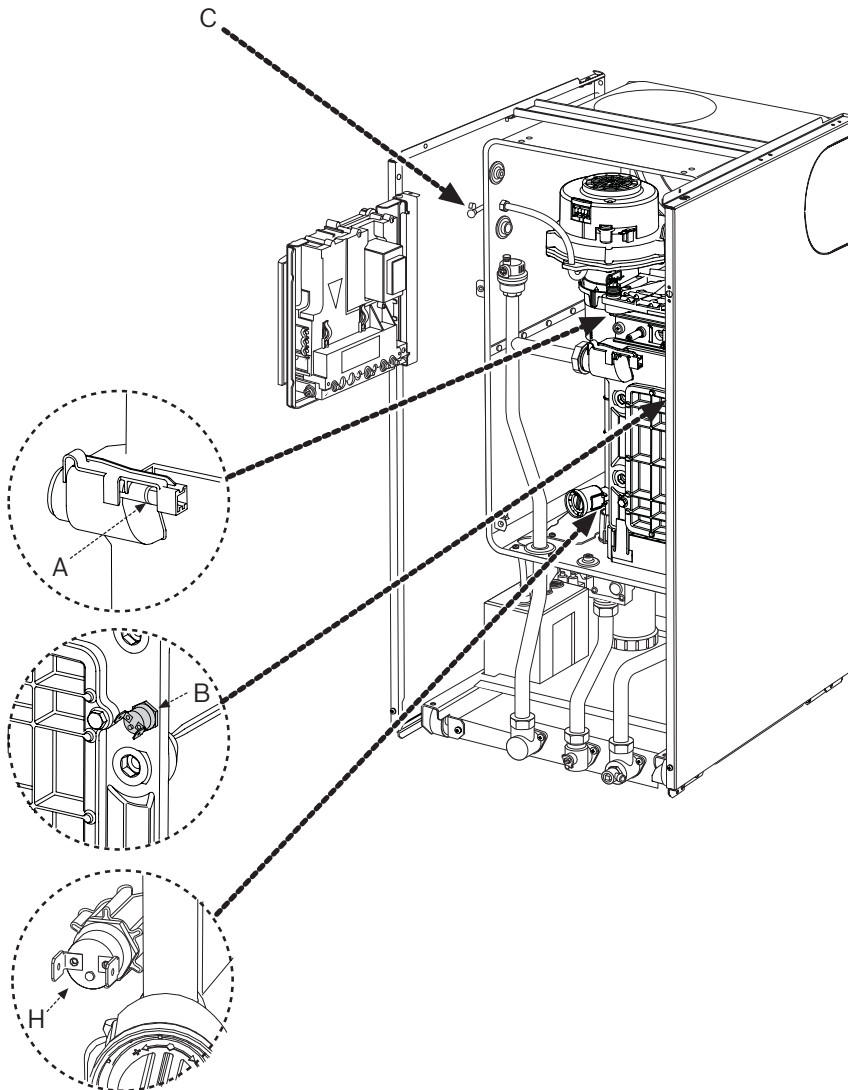

Condensate trap:

- ▶ Move control panel into service position.
- ▶ Remove inner case door.
- ▶ Remove screw retaining trap (F) and push trap downwards until clear.
- ▶ Remove trap from boiler along with pipe to condensate pump.

Gas valve:

- ▶ Check that the gas cock is turned off.
 - ▶ Remove condensate pump.
- 1 ▶ Undo the union, within the inner casing, securing the valve to the gas/air tube.
 - 2 ▶ Remove the black rubber cap from the gas valve (G).
 - 3 ▶ Release the gas inlet union at the inlet.
 - 4 ▶ Remove the solenoid connections at the front of the gas valve.
- ▶ Remove gas valve and gas inlet pipe together.
 - ▶ Transfer the inlet pipe assembly to the new gas valve.
 - ▶ Check for gas tightness when the new gas valve has been fitted.
 - ▶ Re-check the combustion performance.
 - ▶ After re-assembly check CO/CO₂ levels as described in the section "Setting the air/gas ratio"

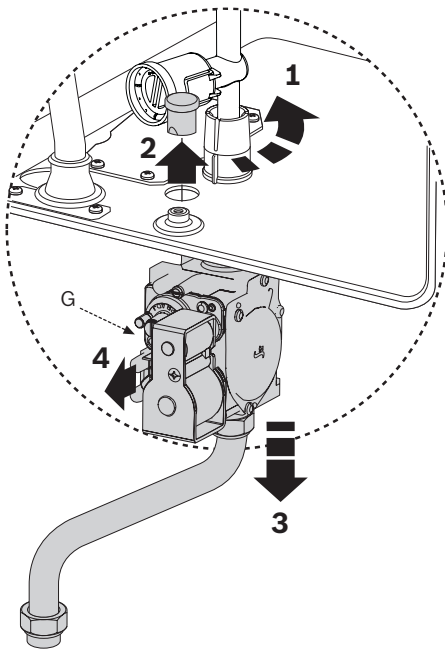
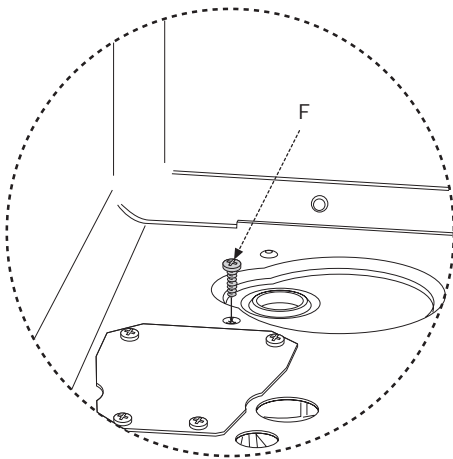

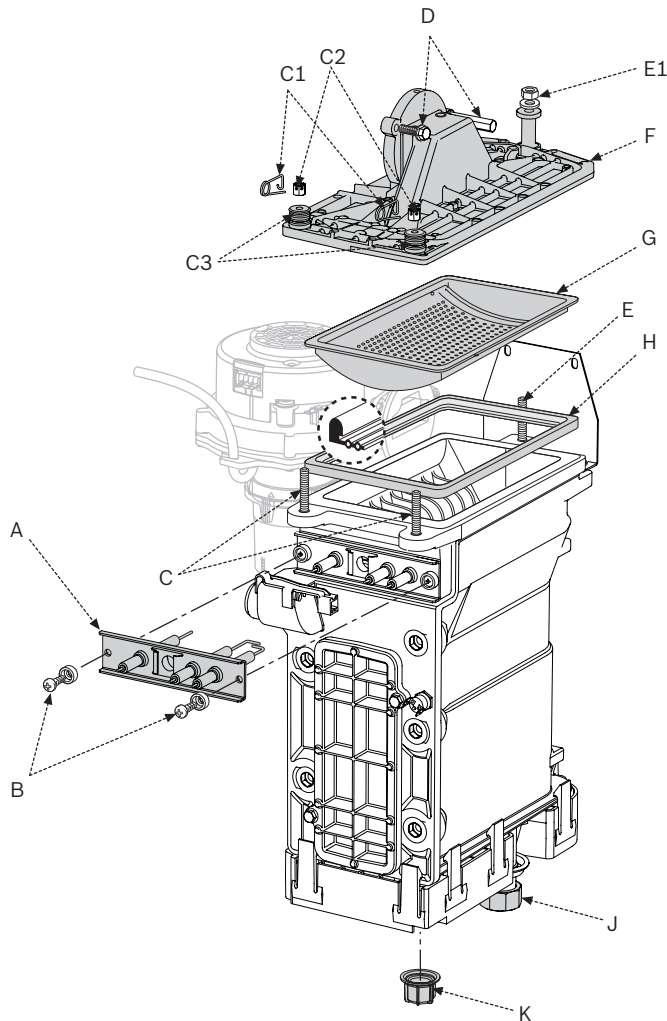
**Electrode assembly:**

- ▶ Switch off the master switch.
- ▶ Isolate appliance from the power supply.
- ▶ Move control panel into service position.
- ▶ Release 4 screws to remove inner case door.
- ▶ Remove the leads from the electrodes.
- ▶ Unscrew the two fixing screws (B) and carefully remove the electrode assembly (A).
- ▶ Replace and re-connect the assembly taking care not to mislay the inspection window.
- ▶ After re-assembly check CO/CO₂ levels as described in the section "Setting the air/gas ratio"

Burner:

- ▶ Check that the gas cock is turned off and the master switch is in the OFF position.
- ▶ Isolate appliance from the power supply.
- ▶ Remove the clips (C1), castellated nuts (C) and springs (C3) from the studs (C).
- ▶ Unscrew and remove the 2 hexagon screws (D) securing the fan.
- ▶ Remove nut and washer (E1) from the rear stud (E).
- ▶ Remove the burner coverplate (F).
- ▶ Remove the burner (G).
- ▶ Re-assemble the new burner in reverse order, inspect seal (H) for damage and replace if necessary.
- ▶ After re-assembly check CO/CO₂ levels as described in the section "Setting the air/gas ratio"

Primary heat exchanger:

- ▶ Isolate appliance from the power supply.
- ▶ Turn off all isolation valves.
- ▶ Drain down appliance.
- ▶ Move control panel into service position.
- ▶ Remove inner case door.
- ▶ Remove fan assembly, burner, gas mixing tube.
- ▶ Disconnect and remove sensors connected to heat exchanger.
- ▶ Remove condensate trap.
- ▶ Remove internal flue elbow and tube from boiler sump.
- ▶ Disconnect return pipe union (J) at the base of the boiler heat exchanger.
- ▶ Remove plastic nut (K) from the base of the inner casing.
- ▶ Remove heat exchanger from inner casing.
- ▶ Ensure heat conductive paste is used on sensors when refitting.
- ▶ Check the seals and replace if necessary.
- ▶ After re-assembly check CO/CO₂ levels as described in the section "Setting the air/gas ratio"

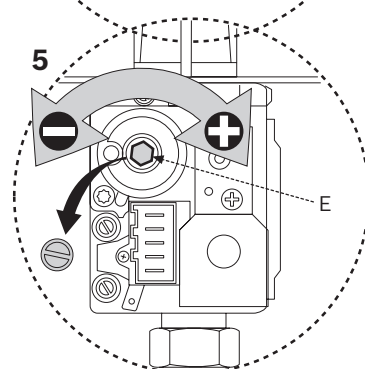
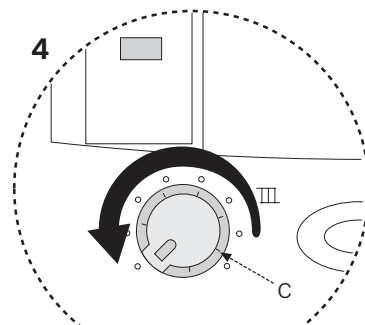
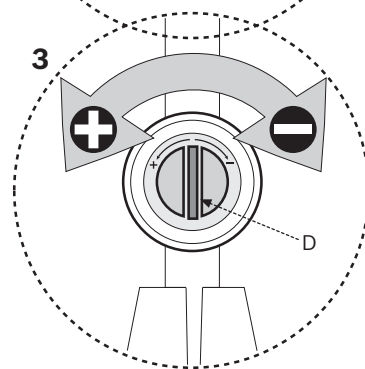
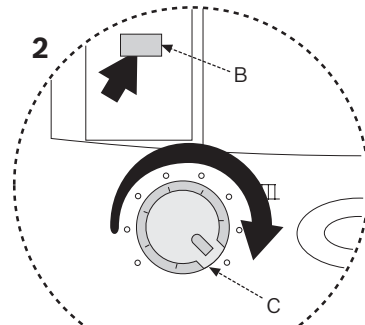
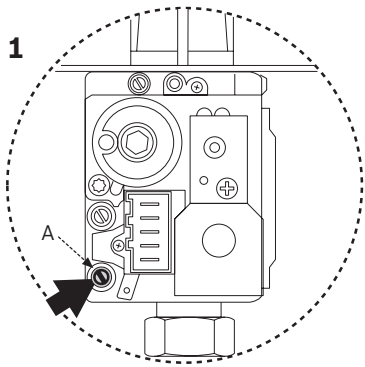

IMPORTANT: The appliance is set at the factory and adjustment to the CO₂ settings (air/gas ratio) is only required where the appliance has been stripped down and assembled or if the fan, burner or gas valve are replaced or the appliance has been converted to a different gas type.

The air/gas ratio may only be adjusted on the basis of a CO₂ measurement at maximum and minimum heat output using an electronic tester. Setting the gas ratio MUST ONLY be carried out by a competent person equipped with a combustion analyser conforming to BS 7927 and competent in its use.

Remove cap (C) on the “flue gas sample point”, as shown in the figure on page 39, and connect a flue gas combustion analyser. Replace the cap after use.

1 ▶ Connect manometer to the inlet pressure point (A) on the gas valve.

▶ Measure the inlet pressure, it should be between 17 - 19mbar (nominally 18 mbar) for Natural Gas and between 35 - 39mbar (nominally 37mbar) for LPG.

2 To adjust the CO₂ it will be necessary to first operate the boiler at maximum output.

▶ Press and hold down the boost button (B) for 10 seconds.

▶ Turn temperature control (C) to maximum, the boiler will then go to maximum output.

Note: the control will resume normal operation after 15 minutes or if the boost button (B) is pressed for more than 1 second.

3 ▶ Remove plastic cap and using a flat bladed screwdriver, set the CO₂ via adjuster (D) referring the table opposite.

Note: CO₂ should be measured 10 minutes after firing the boiler.

▶ Check the CO is less than 200ppm.

4 ▶ Turn the temperature control (C) to minimum. This will make the boiler go to minimum output.

5 ▶ Measure the CO₂ it should now be at the figure for minimum output shown on the table opposite. If not, remove cap and adjust (E) on the gas valve until correct.

▶ Check the CO is less than 200ppm.

▶ Turn temperature control to maximum output and recheck the CO₂. If correct, hold down the boost button (B) for two seconds, the boiler should return to normal operating mode with the blue power indicator permanently illuminated.

▶ Remove manometer and re-seal the inlet pressure point on the gas valve.

▶ Fit a new plastic sealing cover to outlet adjuster (D) and replace the cap on the gas valve.

Greenstar FS 30CDi

GAS TYPE	CO ₂ setting maximum.	CO ₂ setting minimum.
Natural Gas Type H (G20)	9.4 ±0.5%	8.6 ±0.5%
LPG (propane) (G31)	10.8 ±0.5%	10.4 ±0.5%

Greenstar FS 42CDi

GAS TYPE	CO ₂ setting maximum.	CO ₂ setting minimum.
Natural Gas Type H (G20)	9.4 ±0.5%	9.0 ±0.5%
LPG (propane) (G31)	10.8 ±0.5%	10.4 ±0.5%

SHORT PARTS LIST

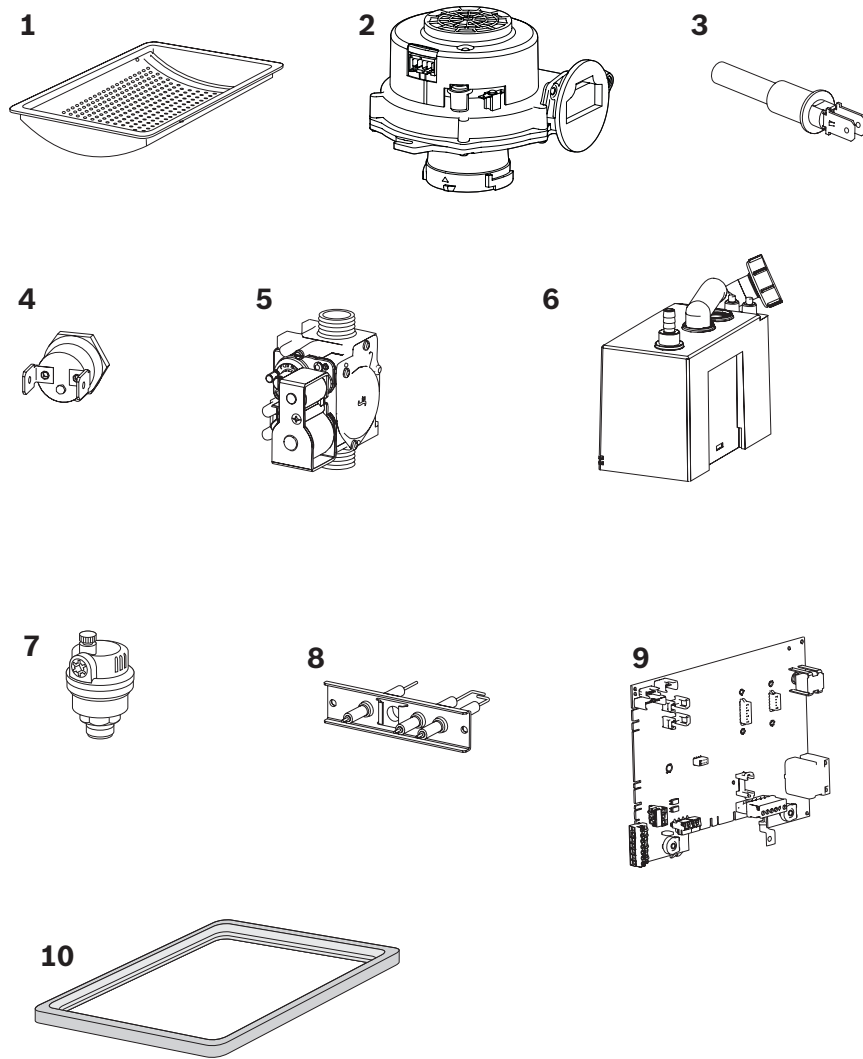

- 1 Burner:
Part No. 8 718 006 658 0
(GC No. E27 200)
- 2 Fan assembly:
30kW Part No. 8 717 204 410 0
(GC No. H66-918)
42kW Part No. 8 717 204 453 0
(GC No. H26-536)
- 3 Temperature sensor:
Part No. 8 714 500 087 0
(GC No. E74 536)
- 4 Temperature limit (Flue or heat exchanger):
Part No. 8 722 963 858 0
(GC No. H08 291)
- 5 Gas valve - SIT 848:
Part No. 8 718 221 347 0
(GC No. H56-469)
- 6 Condensing Pump:
Part No. 8 716 114 077 0
(GC No. H66-(921))
- 7 Auto air vent 3/8" BSP:
Part No. 8 716 140 500 0
(GC No. E00-717)
- 8 Electrodes - set:
Part No. 8 718 107 078 0
(GC No. E74-535)
- 9 Printed circuit board:
Part No. 8 748 300 606 0
(GC No. H66-923)
- 10 Seal - Burner
Part No. 8 711 004 168 0
(GC No. E27-201)

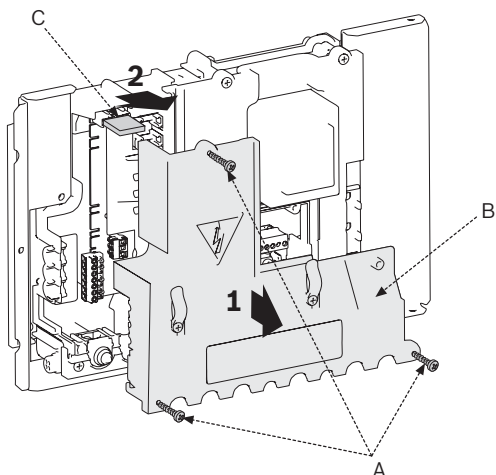

Change code plug:

- 1 ▶ Release three screws (A) to remove cover (B).
 - 2 ▶ Remove and dispose of the existing code plug (C).
 - ▶ Replace with new conversion code plug.
- N.G. code plug number:
 FS 30CDi 1704
 FS 42CDi 1706
- L.P.G. code plug number:
 FS 30CDi 1705
 FS 42CDi 1707
- ▶ Refit panel (B) and secure with three screws (A).

Change gas pipe:

- 4 ▶ Rotate gas pipe (D) anti-clockwise, pull upwards and remove gas pipe.
- 5 ▶ Replace with new conversion gas pipe (E), push downwards and rotate clockwise to lock into position.

Conversion label:

- ▶ Replace existing label with new conversion label.

Adjust the CO₂ level:

- ▶ After re-assembly check CO/CO₂ levels as described in the section "Setting the air/gas ratio".

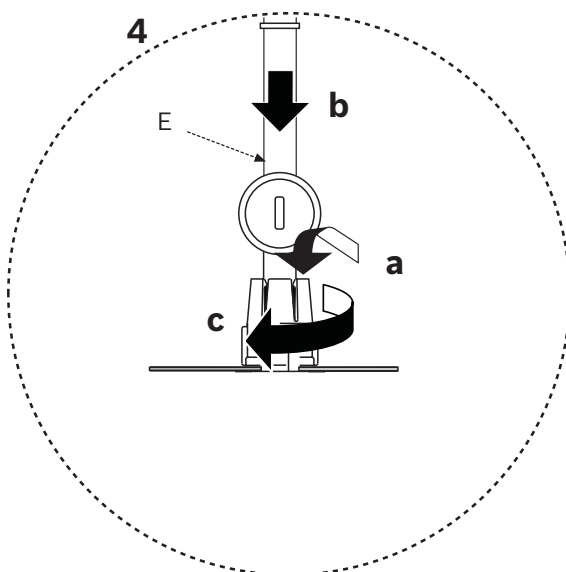
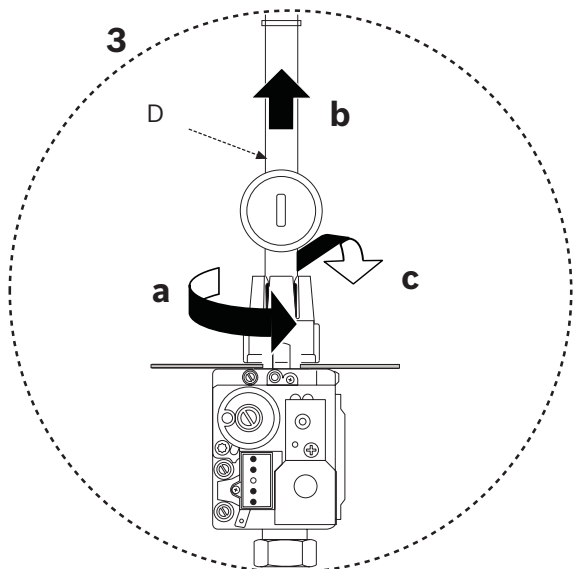

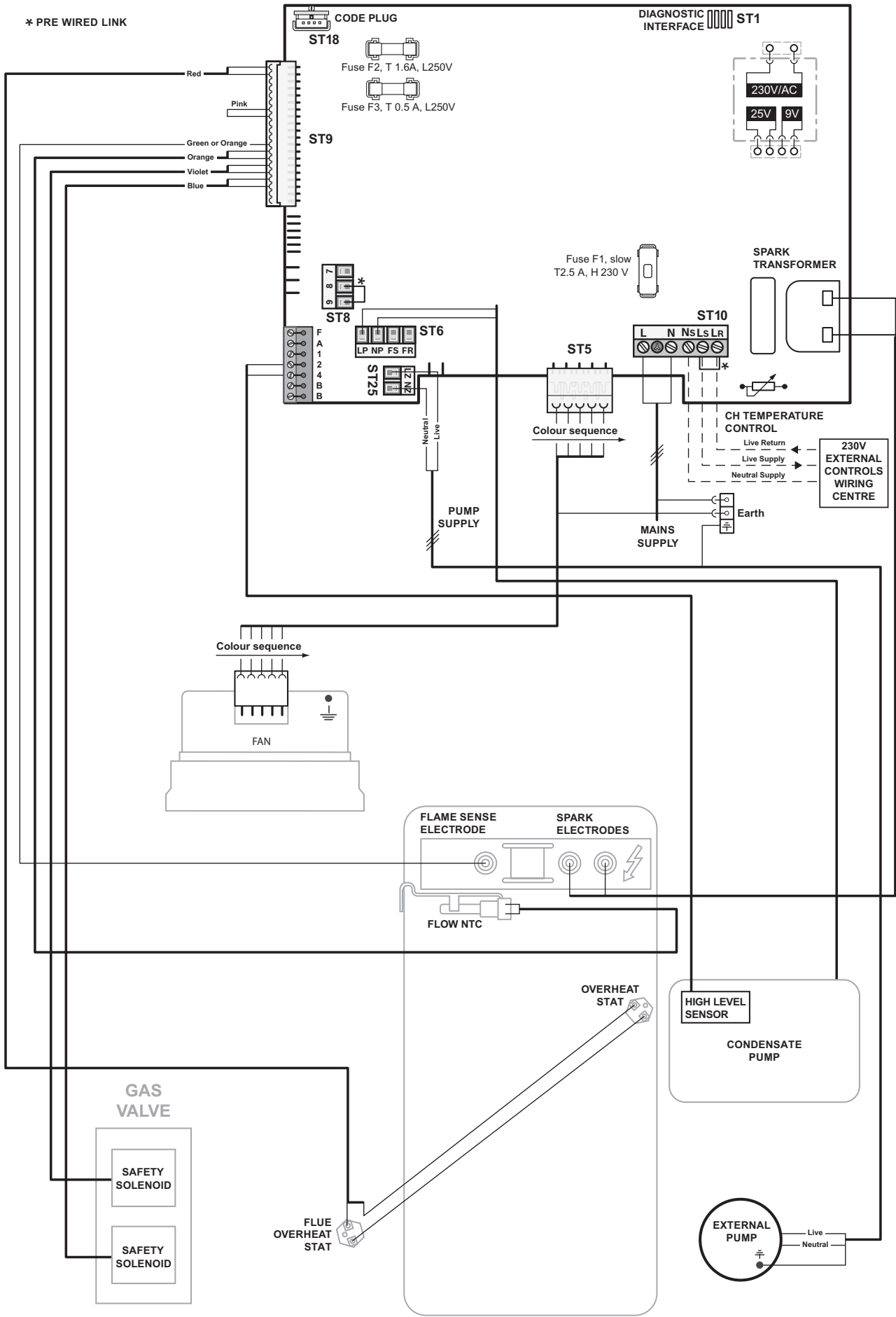

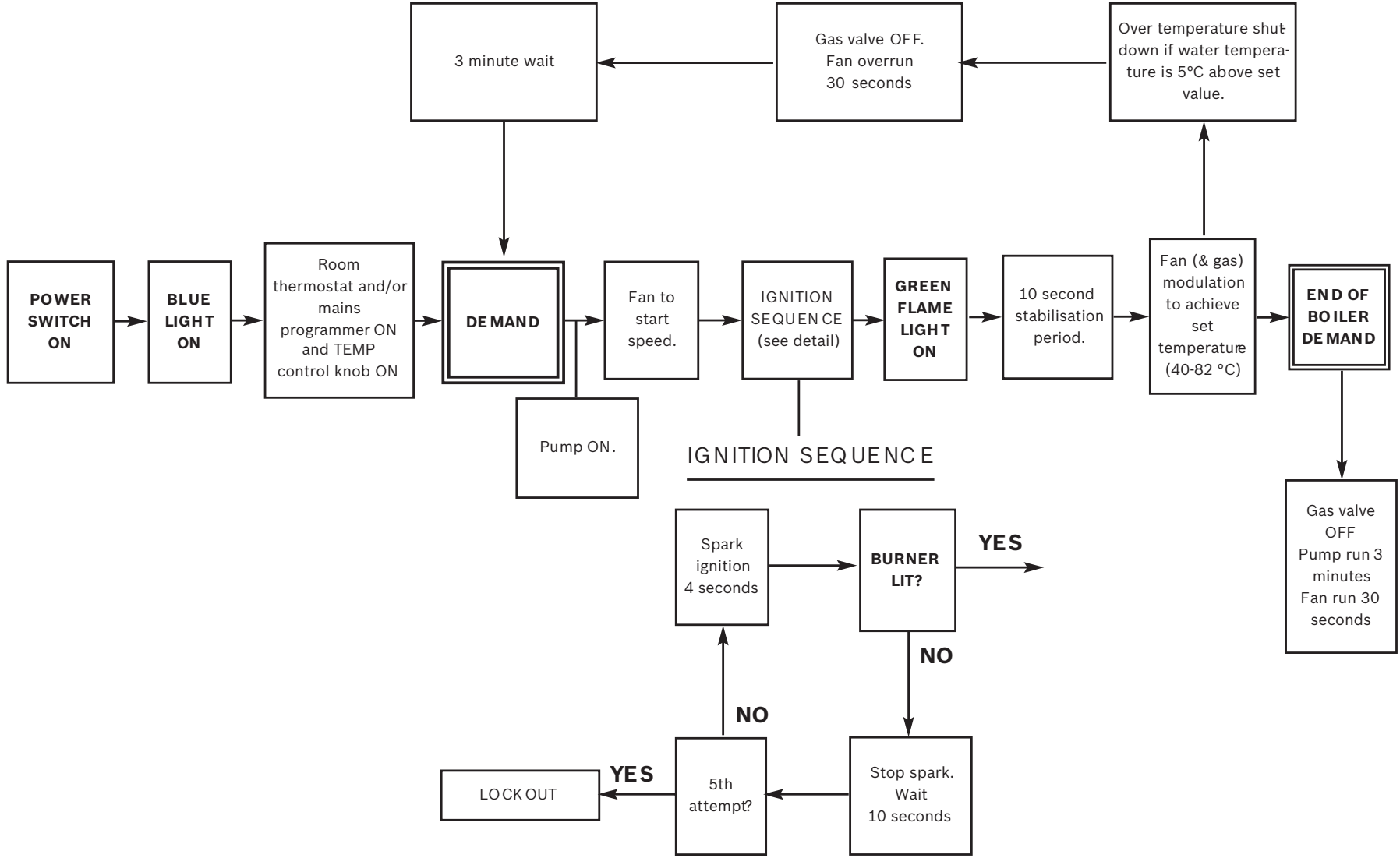

FAULT FINDING

BOILER - FAULTS AND CONDITIONS		
Display code:	Fault description	Check, repair/replace as necessary
A8	EMS communication error	Check all electrical connections, replace control board.
b1	Code plug not detected	Insert code plug correctly, test and replace as necessary.
b2, b3, b4, b5, b6	Data error	Replace control board.
b7	Burner control error	Replace control board.
C6	Fan defect	Check fan, lead, and connector, replace as necessary.
D3	External temp limiter	Connect terminals 8 & 9 on ST8.
D5	Condensate overflow	See condensate pump table.
EA	Flame not detected	Check gas is present, ignition electrodes and harness, flame sense electrode and harness, and operation of gas valve. Replace as necessary.
E2	Primary NTC defect	Check primary NTC sensor and leads, resistance across NTC should be between 36k to 1k Ω
E9	OH stat tripped	Check system pressure, over heat thermostat, and pump operation. Replace as necessary
F0	Internal error	Check all electrical connections, replace board as necessary.
F1	ROM error check	Check all electrical connections, replace board as necessary.
F7	Flame detected after appliance shut off	Check flame sense electrode and harness, and control board for signs of water damage. Replace as necessary
FA	Flame detected after gas shut off	Check flame sense electrode and harness, and control board for signs of water damage. Check gas valve operation. Replace as necessary
Fd	Reset button pressed	Press reset button again

NOTE ; This fault finding information is for guidance only. Worcester, Bosch Group cannot be held responsible for costs incurred by persons not deemed to be competent.

The electronic control system for this boiler incorporates a blue central indicator. This normally confirms the permanent mains supply, but, by flashing during a fault, provides a guide to the cause as listed.

Preliminary checks:

Preliminary electrical system checks are the first electrical checks to be carried out during a fault finding procedure.

On completion of the Service/Fault finding task which has required the breaking and remaking of electrical connections, check:

- a) EARTH CONTINUITY
- b) SHORT CIRCUIT CHECK
- c) POLARITY
- d) RESISTANCE TO EARTH.

CONDENSATE PUMP - OPERATING LAMPS AND FAULT CONDITIONS			
Ready for operation	=	Steady green light	
Fault	=	Red light	
Pump running	=	Flashing green light	
Operating lamps		Cause	Solution
Green	Red		
Off	Off	Mains plug not plugged in Power failure	Insert plug Check mains and fuse
Flashing	Flashing	Dry-run (poss. air in pump)	Pump restarts automatically after one minute
On	Flashing	Pump blocked	Visual inspection of the pump inlet in the tank and removal or rinsing out of dirt/foreign bodies
On	On	Level exceeds alarm level	Pressure hose / non-return valve blocked (clean or remove kink if applicable)
Off	Flashing	Pump blocked and alarm level exceeded	Visual inspection of the pump inlet in the tank and removal or rinsing out of dirt/foreign bodies

SERVICE RECORD

It is recommended that your heating system is serviced regularly and that the appropriate Service Record is completed.

Service Provider

Before completing the appropriate Service Record below, please ensure you have carried out the service as described in the manufacturer's instructions.

Always use the manufacturer's specified spare part when replacing controls.

SERVICE 1 Date

Energy Efficiency Checklist completed? Yes No

Engineer Name _____

Company Name _____

Telephone Number _____

CORGI ID Number _____

Comments _____

Signature _____

SERVICE 2 Date

Energy Efficiency Checklist completed? Yes No

Engineer Name _____

Company Name _____

Telephone Number _____

CORGI ID Number _____

Comments _____

Signature _____

SERVICE 3 Date

Energy Efficiency Checklist completed? Yes No

Engineer Name _____

Company Name _____

Telephone Number _____

CORGI ID Number _____

Comments _____

Signature _____

SERVICE 4 Date

Energy Efficiency Checklist completed? Yes No

Engineer Name _____

Company Name _____

Telephone Number _____

CORGI ID Number _____

Comments _____

Signature _____

SERVICE 5 Date

Energy Efficiency Checklist completed? Yes No

Engineer Name _____

Company Name _____

Telephone Number _____

CORGI ID Number _____

Comments _____

Signature _____

SERVICE 6 Date

Energy Efficiency Checklist completed? Yes No

Engineer Name _____

Company Name _____

Telephone Number _____

CORGI ID Number _____

Comments _____

Signature _____

SERVICE 7 Date

Energy Efficiency Checklist completed? Yes No

Engineer Name _____

Company Name _____

Telephone Number _____

CORGI ID Number _____

Comments _____

Signature _____

SERVICE 8 Date

Energy Efficiency Checklist completed? Yes No

Engineer Name _____

Company Name _____

Telephone Number _____

CORGI ID Number _____

Comments _____

Signature _____

SERVICE 9 Date

Energy Efficiency Checklist completed? Yes No

Engineer Name _____

Company Name _____

Telephone Number _____

CORGI ID Number _____

Comments _____

Signature _____

SERVICE 10 Date

Energy Efficiency Checklist completed? Yes No

Engineer Name _____

Company Name _____

Telephone Number _____

CORGI ID Number _____

Comments _____

Signature _____

Worcester, Bosch Group
Cotswold Way, Warndon, Worcester WR4 9SW
Tel. 0844 892 9900 Fax. 01905 754619
Worcester, Bosch Group is a brand name of Bosch Thermotechnology Ltd.
worcester-bosch.co.uk

8 716 115 216c (03.2010)

