

Digital Inverter R32

1 Phase Model

Outdoor units

RAV-GM301ATP-E/TR

RAV-GM401ATP-E/TR

RAV-GM561ATP-E/TR

RAV-GM801ATP-E/TR

RAV-GM1101ATP-E/TR

RAV-GM1401ATP-E/TR

RAV-GM301ATJP-E

RAV-GM401ATJP-E

RAV-GM561ATJP-E

RAV-GM801ATJP-E

RAV-GM1101ATJP-E

RAV-GM1401ATJP-E

3. Outdoor Unit

2-2-1. Specifications

2-2-2. Dimension

2-2-3. Wiring Diagrams

2-2-4. Refrigerant Cycle Diagram

2-2-5. Sound Characteristic

2-2-6. Connecting Pipe Length and Lift Difference Between Indoor Units VS. Capacity Correction Value

3-1 Specification

Model	Outdoor unit (RAV-) (RAV-)	GM301ATP-E/TR GM301ATJP-E	GM401ATP-E/TR GM401ATJP-E	GM561ATP-E/TR GM561ATJP-E	GM801ATP-E/TR GM801ATJP-E	GM1101ATP-E/TR GM1101ATJP-E	GM1401ATP-E/TR GM1401ATJP-E
Power supply	1 phase 220V-240V / 50Hz, 1 phase 220V / 60Hz (Power exclusive to outdoor is required)						
Compressor	Type	Hermetic Compressor					
	Motor (kW)	0.75	1.10	1.10	1.60	3.00	
	Pole	4					
Refrigerant Charged	(kg)	0.8	1.4	1.1	1.7	2.1	
Refrigerant Control	(kg)	Pulse motor valve					
Outer dimension	Height (mm)	550		550		890	
	Width (mm)	780		780		900	
	Depth (mm)	290		290		320	
Appearance	Silky shade (Muncel 1Y 8.5 / 0.5)						
Total weight	Main unit (kg)	33	39	40	44	68	
Heat Exchanger	Finned tube						
Fan Unit	Fan	Propeller fan					
	Standard air flow (m ³ / h)	30	37	40	45	68	70
	Motor (W)	43				100	
Inter Connecting Pipe	Standard length	7.5					
	Min. length (m)	2.0		5.0			
	Max. total length (m)	20.0		30.0		50.0	
	Additional refrigerant charge under long piping connector	20 g / m (15 m. to 20 m.)		20 g / m (21 m. to 30 m.)	40 g / m (21 m. to 30 m.)	40 g / m (31 m. to 50 m.)	
	Height difference	Outdoor low (m)	10		30		
Outdoor high (m)		10		30			
Flare Connections	Gas side (mm)	9.5	12.7	12.7	15.9		
	Liquid side (mm)	6.4	6.4	6.4	9.5		
Sound pressure level	Cooling / Heating (dB)	46 / 47	49 / 50	46 / 48	48 / 52	54 / 57	55 / 57
Sound power level	Cooling / Heating (dB)	61 / 62	64 / 65	63 / 65	65 / 69	70 / 74	70 / 74
Operating Range	Cooling (°C)	-15 / 46					
	Heating (°C)	-15 / 15					

**RAV-GM561ATP-E/TR, RAV-GM801ATP-E/TR, RAV-GM1101ATP-E/TR,
RAV-GM1401ATP-E/TR (*ATJP-E)**

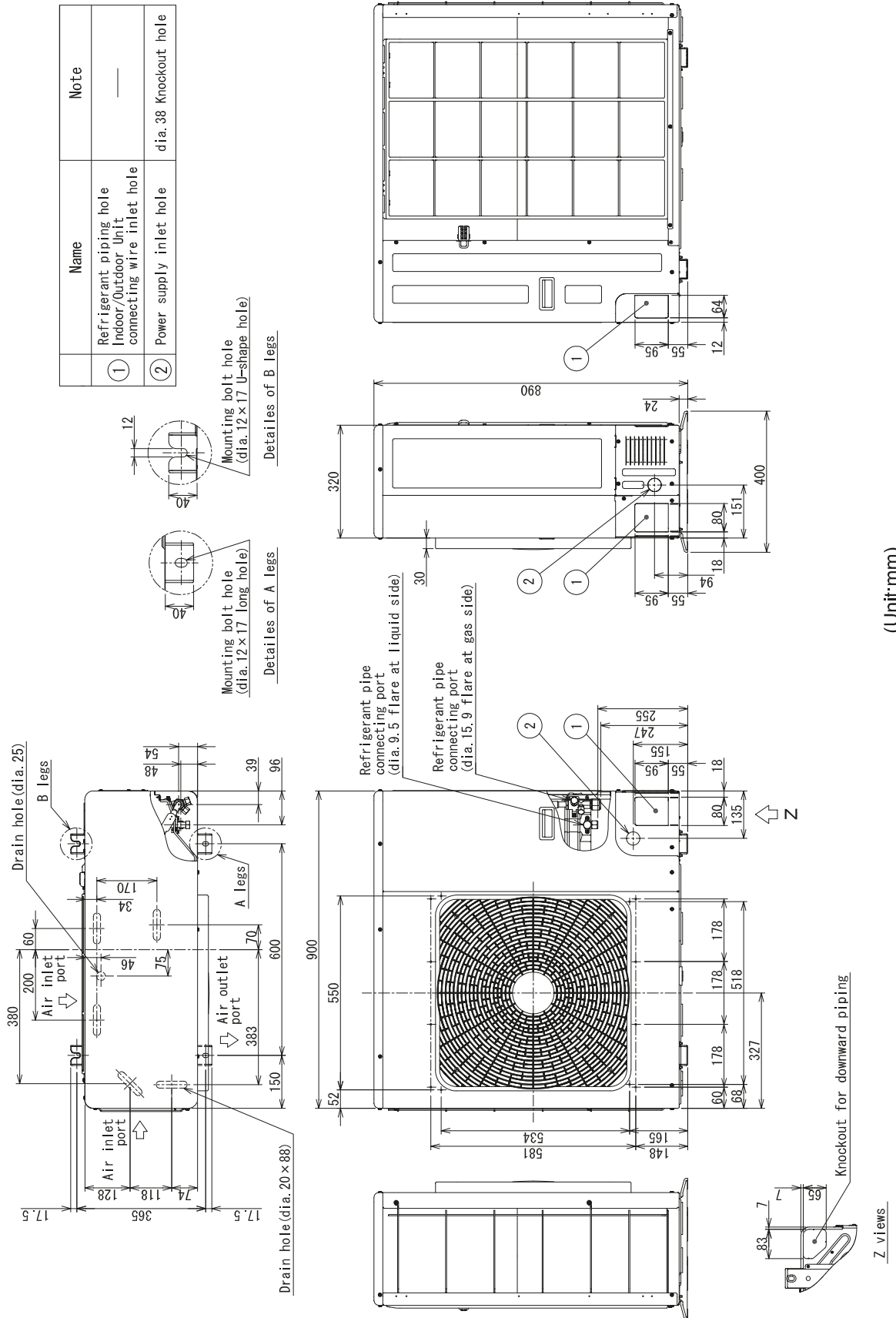

(Unit:mm)

RAV-GM561ATP-E/TR (*ATJP-E)

Sound pressure level (dB(A))	Cooling	Heating
	46	48

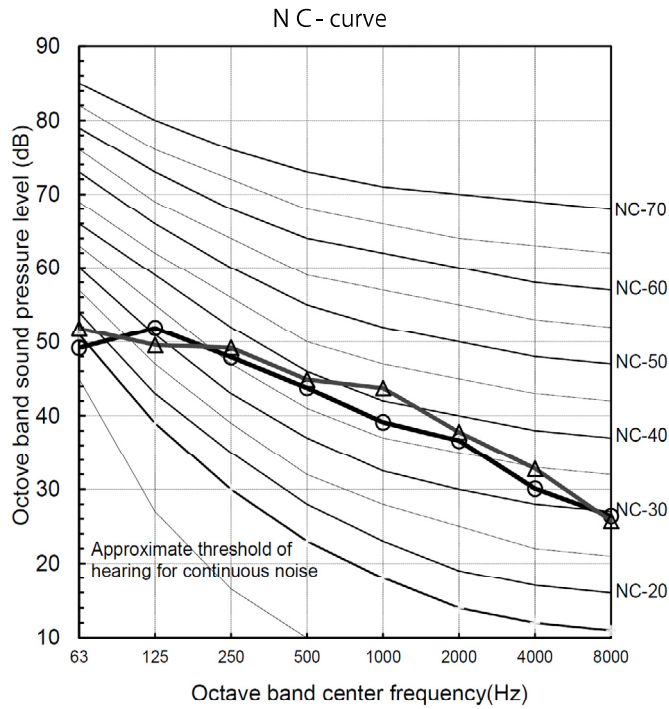

RAV-GM801ATP-E/TR (*ATJP-E)

Sound pressure level (dB(A))	Cooling	Heating
	48	52

