

OPUS 40-60-95 SINGLE & TWIN FANS

NEW STYLISH WALL & CEILING FAN CONTINUING NUAIRE'S
PEDIGREE FOR HIGH PERFORMANCE, LOW NOISE SOLUTIONS.



BENEFITS

VERY QUIET OPERATION

Units offer high performance with low noise levels.

MOST EFFICIENT SYSTEMS

Latest DC motor design providing high performance with the lowest possible Specific Fan Power available in its class. Will conform to Part L2.

GUARANTEED VENTILATION

The most compact cost effective twinfan available for the duty range.

QUICK & EASY TO INSTALL

Unit delivered complete with surface or recessed kit.

SIMPLE TO COMMISSION

Integral control facility enables the duty to be precisely set without the need for additional controls.

LOW MAINTENANCE COST

Easy clean foam filters protect motor and fan assembly, reducing maintenance costs and extending fan life. Foam filters fitted as standard.

CONTROLS

A choice of 'on-board' and 'remote' control options are available, including Ecosmart energy efficient controls.

FLEXIBLE SOLUTION - SIDE DISCHARGE

Unit can be installed horizontally or vertically. Range offers surface, recessed for duct mounted options. Refer to page 213.

CONTINUOUS VENTILATION

Twin fans allow for automatic changeover to standby fan in event of fan failure.

SPECIALIST OPTION

Vandal proof grille available for extra security and protection.

WARRANTY

Opus 40, 60 & 95 have a 3 year warranty. Ecosmart models have a 5 year warranty.

Note: if you have a BMS system the Ecosmart model will be required.

For a full range of Ecosmart sensors and enablers please refer to the controls and ancillaries section.

INSTALLATION OPTIONS



Unit can be installed as surface mounted...



...or recessed mounted.

TWIN FANS

OPUS 40 - 60 - 95

TECHNICAL INFORMATION

PERFORMANCE - OPUS EXTRACT FANS

Opus 40, 60 and 95

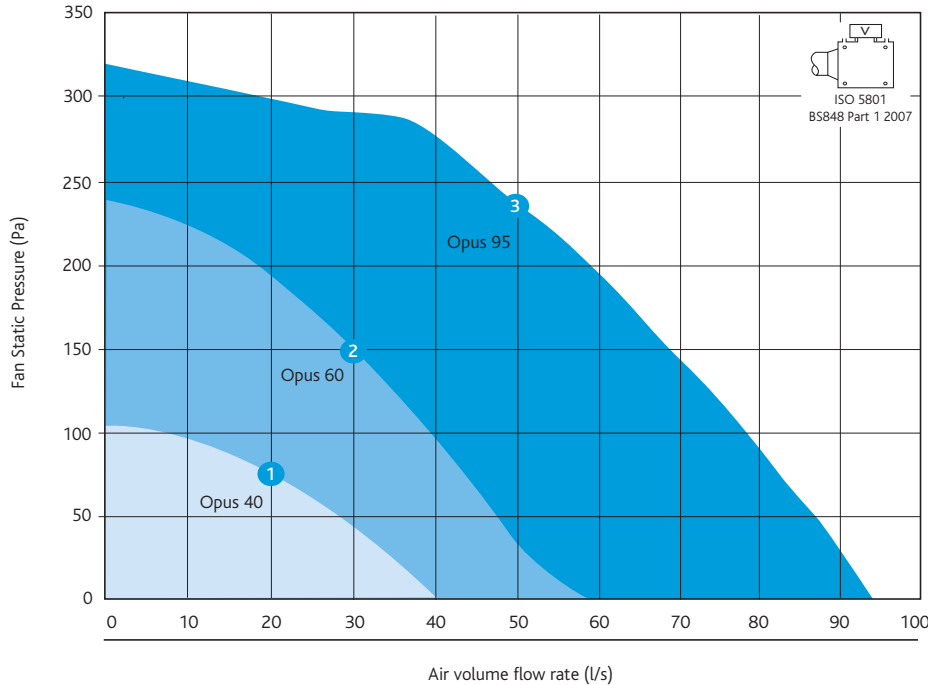

Note: Opus 95 has $\frac{2}{3}$ rds duty on fan failure.

Casing



Code description (Example)

OPUS 40T - E S P

1 2 3 4 5

1 = Opus range

2 = 40, 60 or 95l/s

3 T= Twin fan

S = Single,

D = Dual fan $\frac{2}{3}$ rds duty on fan failure

4 = Ecosmart control or speed control

5 = P.I.R. or run on timer

OPUS EXTRACT FANS - MODELS AND CODING

| MODEL | OPUS40 (SINGLE & TWIN FAN) | OPUS60 (SINGLE & TWIN FAN) | OPUS95 (DUAL FAN) |
|---|----------------------------|----------------------------|-------------------|
| | surface/recessed | surface/recessed | surface/recessed |
| Single Fan (basic on/off, with trickle switch) | S | S | - |
| Twin Fan (basic on/off, with trickle switch) autochanger/duty share | T | T | - |
| Dual Fan ($\frac{2}{3}$ rds duty on fan failure) | - | - | D |
| Speed control (built in trickle & boost) | C | C | C |
| Ecosmart (speed control/sensors) | ES | ES | ES |
| Run on timer | R | R | R |
| PIR (run on timer included) only available on Ecosmart model (built in) | P | P | P |
| Inlet filter | M | M | M |

ANCILLARIES

| | | | |
|---|---------------|---------------|---------------|
| Remote Fail Indicator | OPUS-RFI | OPUS-RFI | OPUS-RFI |
| Remote Fail Indicator (for Ecosmart model only) | ES-AVIZ | ES-AVIZ | ES-AVIZ |
| External Humidistat | HUMISEN | HUMISEN | HUMISEN |
| External Humidistat (for Ecosmart model only) | ES-HUMIDISTAT | ES-HUMIDISTAT | ES-HUMIDISTAT |
| Vandal proof cover | OPUS-VPC | OPUS-VPC | OPUS-VPC |
| Backdraft shutter in white | PVC494WH | PVC494WH | PVC494WH |

For a full range of Ecosmart sensors and enablers please refer to the controls and ancillaries section.

For foam filter spares contact Nuaire.

Note: ES-PIR & ES-TEMPZ are also available, for details refer to controls section.

ELECTRICAL & SOUND

| Fan Unit | Frequency Hz | | | | | | | | Open inlet dBA @ 3m | FLC amps | Power watts |
|------------------|--------------|-----|-----|-----|----|----|----|----|------------------------|-------------|----------------|
| | 63 | 125 | 250 | 500 | 1K | 2K | 4K | 8K | | | |
| Opus 40 | 45 | 47 | 53 | 49 | 47 | 48 | 43 | 33 | 36 | 0.1 | 14 |
| Opus 60 | 48 | 57 | 57 | 55 | 54 | 55 | 51 | 44 | 43 | 0.32 | 43 |
| Opus 95 Dual Fan | 50 | 57 | 62 | 58 | 57 | 57 | 52 | 46 | 46 | 0.6 | 72 |

DIMENSIONS (MM)

Surface mounted unit

Front view

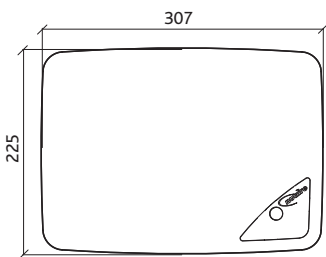

Side view

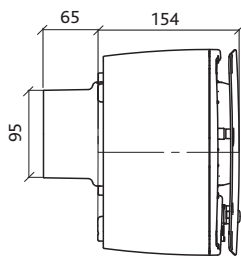

Back view

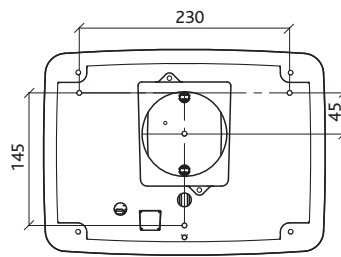

Top view

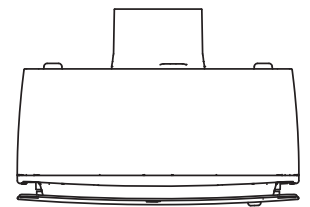

Recessed mounted unit rear discharge

Front view

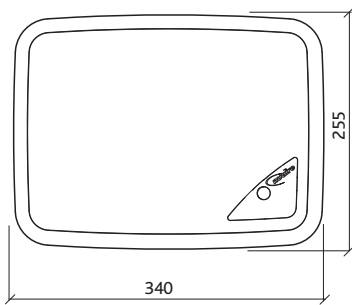

Side view

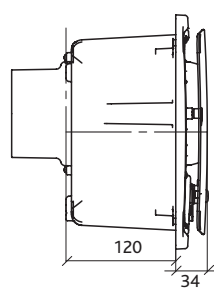

Back view

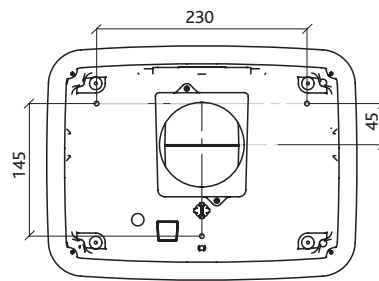

Top view

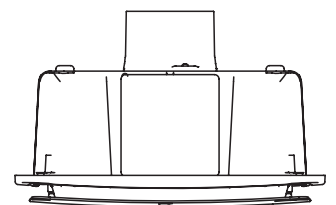

Recessed mounted unit side discharge

Front view

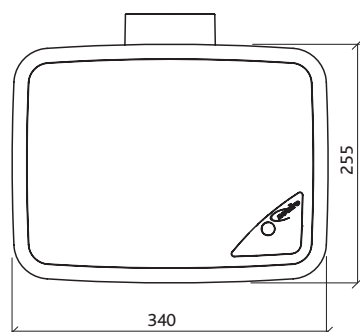

Side view

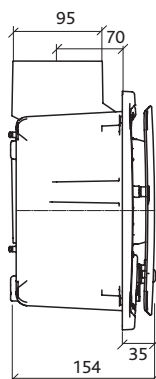

Back view

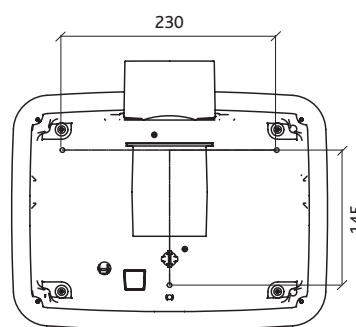

Top view

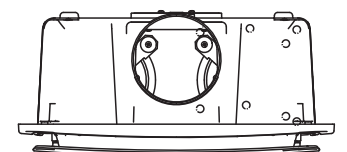

WIRING - OPUS 40 - 60 - 95

Unit ventilating one room

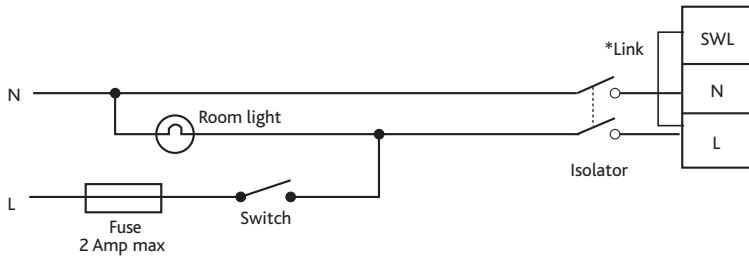

Unit ventilating one room (Using run on circuit)

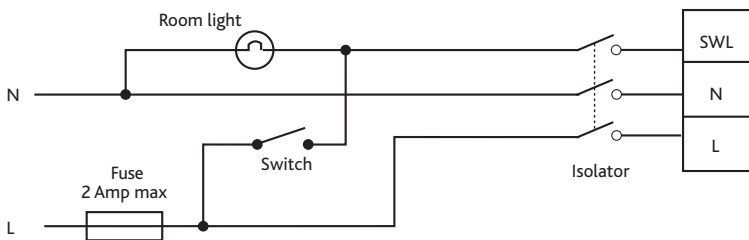

*Note: Link also required when used in conjunction with remote user control (ES-UCF).

ECOSMART CONTROL OPTION

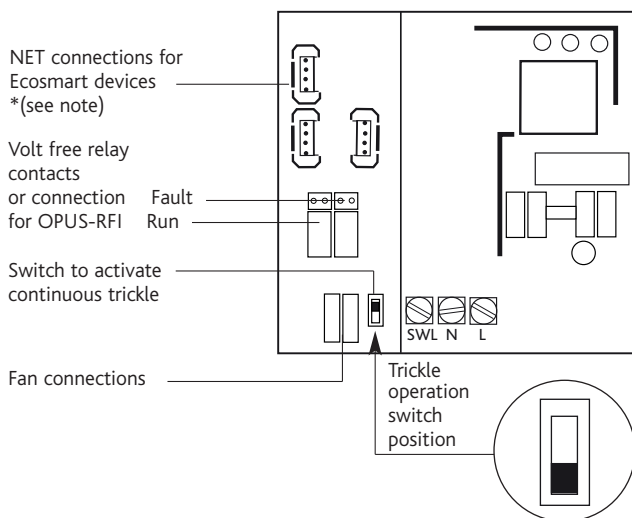

CONSULTANTS SPECIFICATION

OPERATION

The extract fans shall be as indicated on the drawings and shall be in accordance with the fan schedule in the specification. The vitiated air shall be extracted from each area via ductwork as shown. All necessary ductwork fittings and ancillaries shall be allowed for by the mechanical sub contractor.

The extract fan shall automatically vary its speed as it receives signals from one of the interconnected sensors sited in the rooms being ventilated. When the signal is received the fan shall have the ability to increase speed gradually until the required level is achieved or it will work on a trickle and boost principle i.e. increase ventilation rate from the continuous background rate to the design maximum in one step.

FAN SPECIFICATION

The fans shall have low energy, high efficiency DC fan/motor assembly with sealed for life bearings.

Motors shall have locked rotor protection to prevent overheating in the event of fan failure. The case shall be 100% recyclable with all parts supplied to enable either surface or recessed mounting. It shall have noise levels and power requirements as detailed in the specification and in accordance with the manufacturers details.

The recessed unit shall be capable of discharging the air either from the rear of the case or the side via spigots suitable for 100mm diameter ductwork.

For commissioning purposes the unit can have a miniature control panel mounted in its fascia hidden behind the front cover facilitating high and low speed adjustment (trickle and boost) together with run on timer (1- 60minutes) The front cover shall be removable without the aid of tools. Any adjustments shall be quickly and easily achieved with a standard screwdriver. The control panel shall also have status indication lamps visible behind the corner "window".

Run and standby versions shall have autochangeover and duty share as standard, the fan shall changeover every twelve hours of run time to maximise the units effective life span. All models shall have foam filters as standard.

CONTROL SPECIFICATION

The fan unit selected shall have the following functions integrally mounted within the fan unit on a purpose made PCB, all such components pre-wired and factory fitted by the manufacturer.

CONTROL OPTIONS

All models to have power and fan failure indication visible behind the front cover.

Base model – on/off control with facility for continuous background ventilation.

C – full speed control of both background and boost ventilation.

R – 1-60 minute run-on timer.

P – Integrated passive infrared detection to trigger the units to boost (Ecosmart model).

ES – ECOSMART CONTROL OFFERING:

- Integrated Infinitely variable speed control.
- Integral background ventilation commissioning facility.
- Integral boost ventilation commissioning facility.
- Autochangeover and duty share (twin fan unit only).
- Integral adjustable run on timer.
- Integral S/L terminal for boost trigger from remote switch, e.g. light switch etc.
- 3no. IDC sockets for interconnection of Ecosmart fans or low voltage sensors using pre-plugged 4-core low voltage cable.

Multiple fans can be interconnected and run from one or more sensor or controller.

- Remote volt free run and fail status indication.
- Run and fail relays for connection to BMS.
- Facia mounted fan failure, system status indication as follows:
 - Fan 1 status.
 - Fan 2 status.
 - Power to fan.
 - System standby.

5 years parts and labour warranty.

The unit shall be of the Opus type as manufactured by Nuaire.

INSTALLATION

By the appointed contractor.

Mechanical installation requires mounting of the extract unit in the designated position and connection to the associated duct work. Electrical installation requires the provision and connection of single phase electrical supply at the fan.

The manufacturer's recommendations should be observed at all times.