

Internal Room Elevation

Scale: 1:10

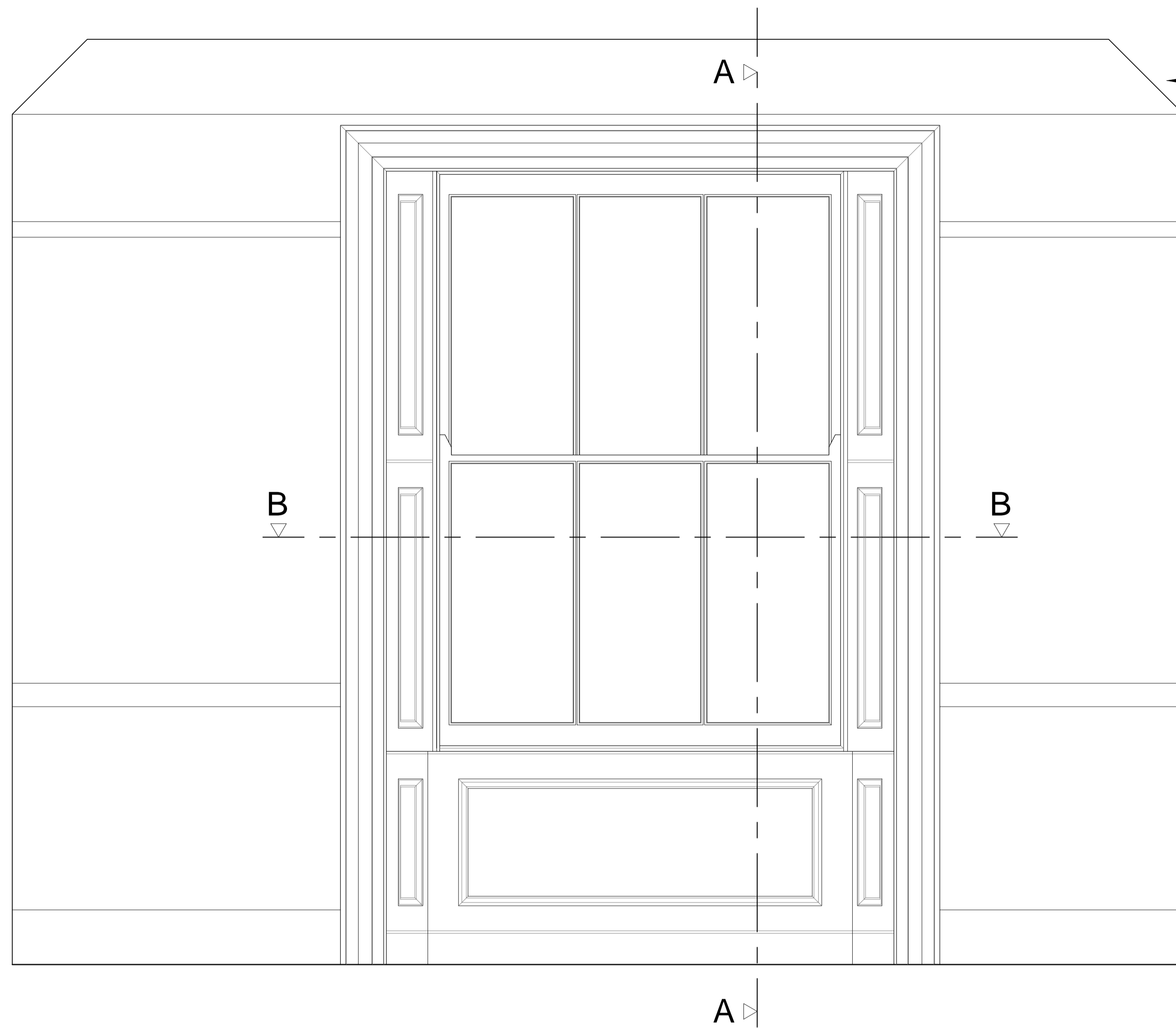

Ceiling cornice indicatively shown

Section A-A through External Wall

Scale: 1:10

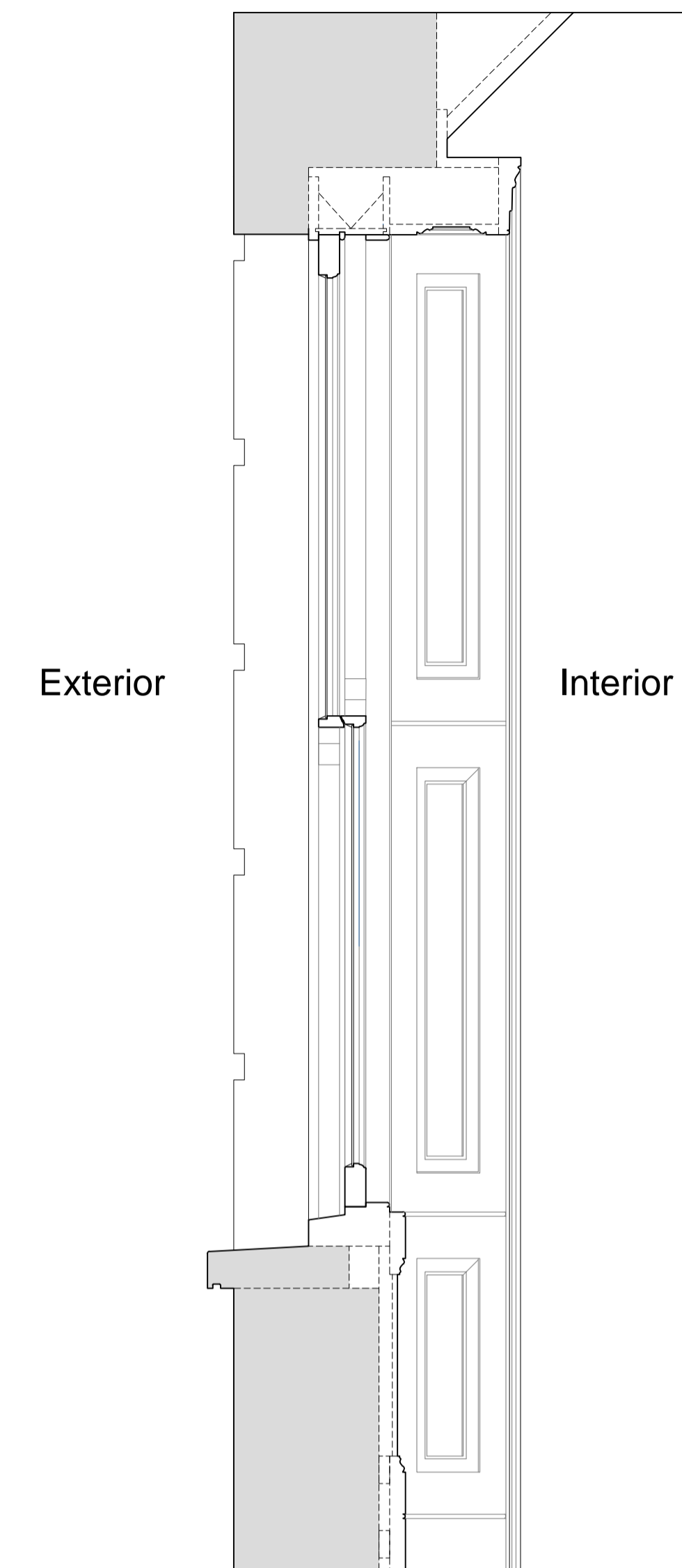

Plan Section B-B

Scale: 1:10

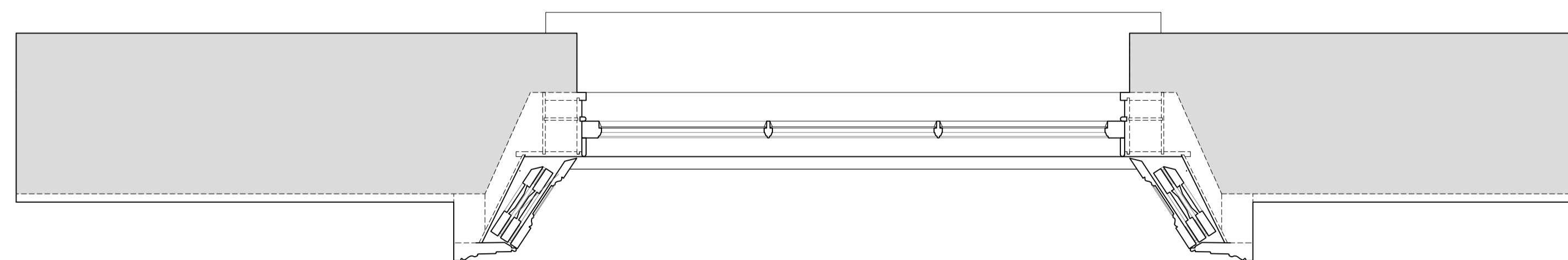

Revision	Date	Amendment
1.0	08-01-2018	Issued for listed building consent application
2.0	16-08-2018	Additional information added

Do not reproduce this drawing without written permission
All dimensions are in millimetres unless stated otherwise

HS2

High Speed (HS2) Limited
25th Floor
One Canada Square
Canary Wharf
London E14 5AB

COSTAIN SKANSKA

Costain Skanska Joint Venture
1st Floor
The Podium
1 Eversholt Street
London NW1 2DN

Site Address:
28 Morningside Terrace, London NW1

Drawing Title:
Ground Floor Sitting Room: EXISTING Window Joinery Details -
Sheet 1 of 8

Drawn by: GA
Checked by: ED
Prepared by: PB
Presentation Scale: as shown @ A1

Date: 16-08-2018
Drawing No: 2016-005-28MT-EX-GF-J-01
Revision: 2.0

Drawing Not For Construction

Internal Room Elevation with Secondary Glazing Installed

Scale: 1:10

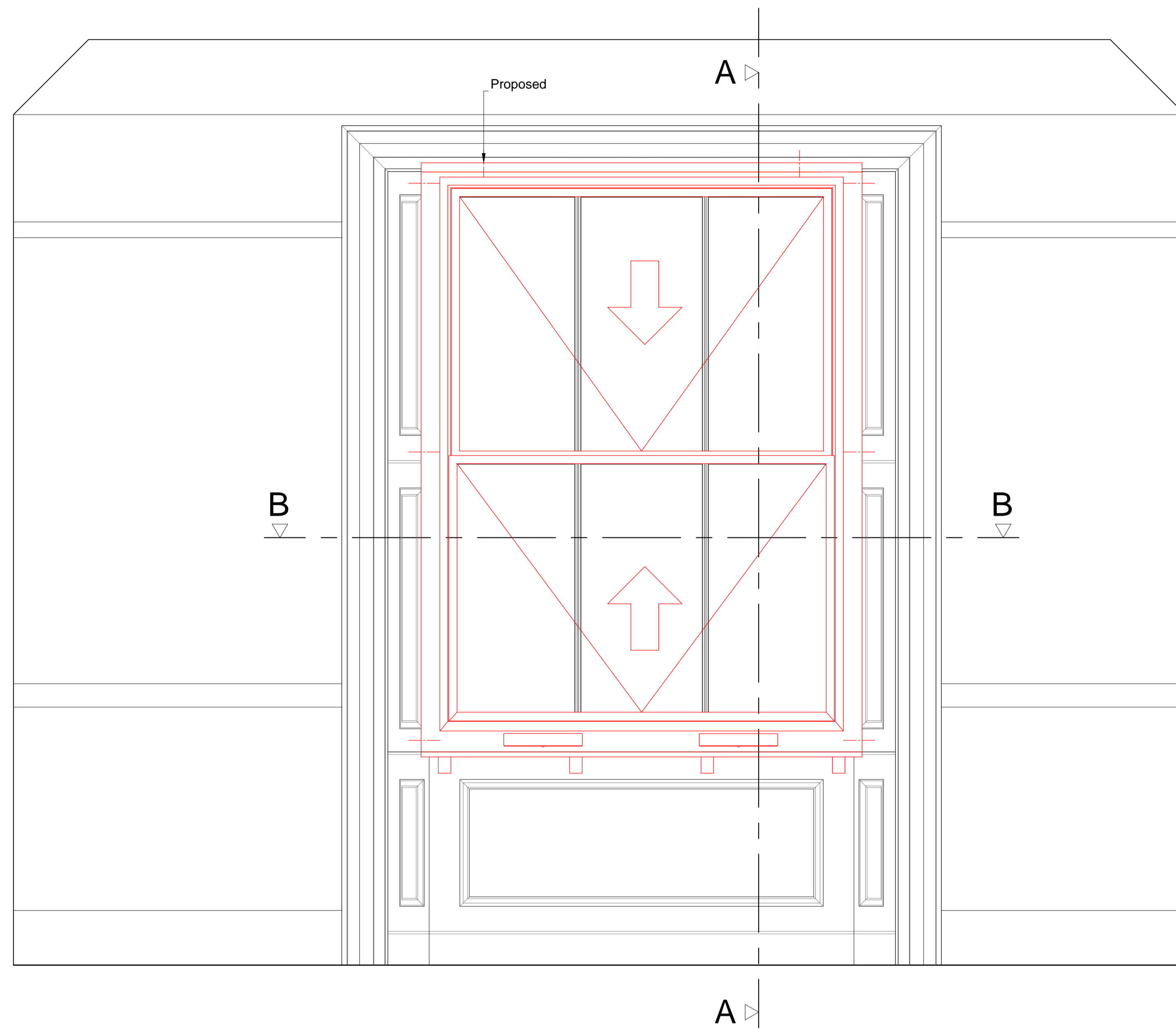

Section A-A through External Wall with Secondary Glazing Installed

Scale: 1:10

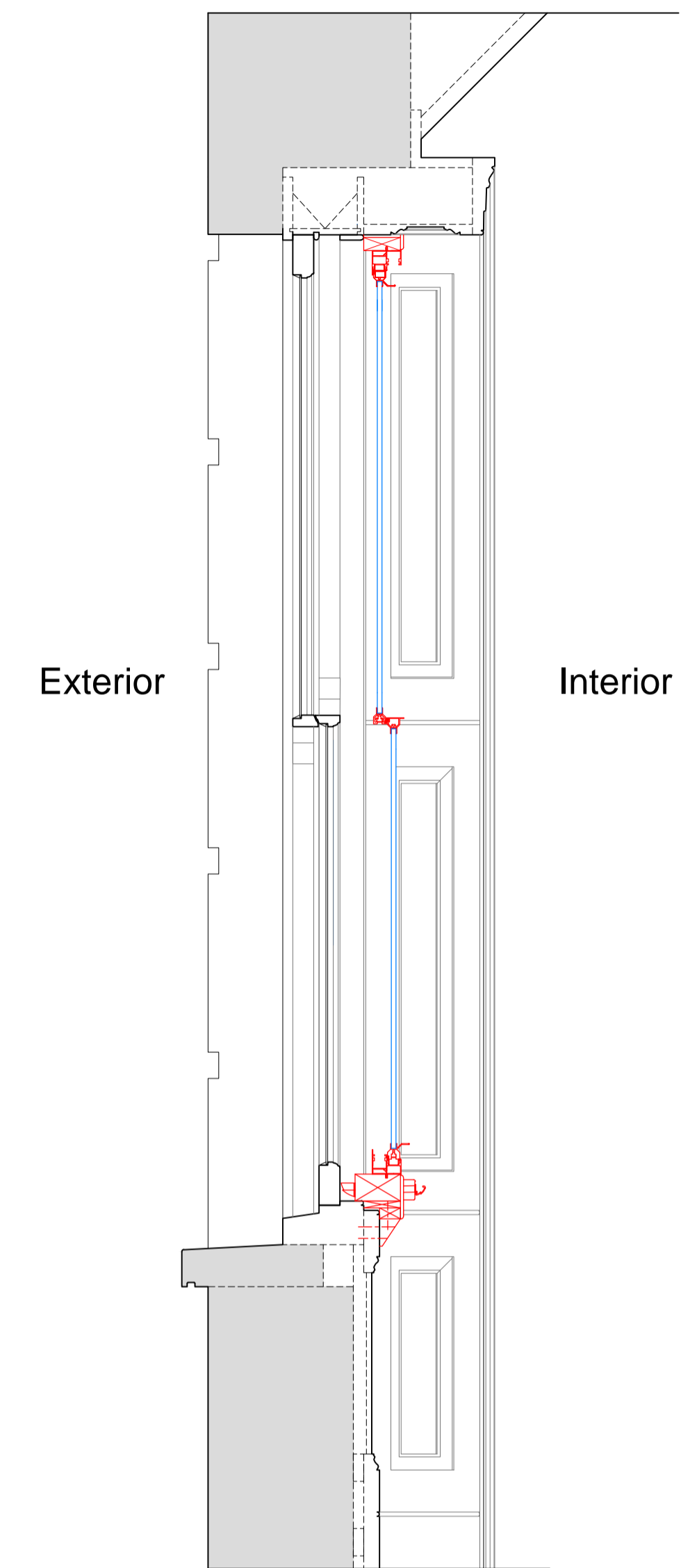

Plan Section B-B with Secondary Glazing Installed

Scale: 1:10

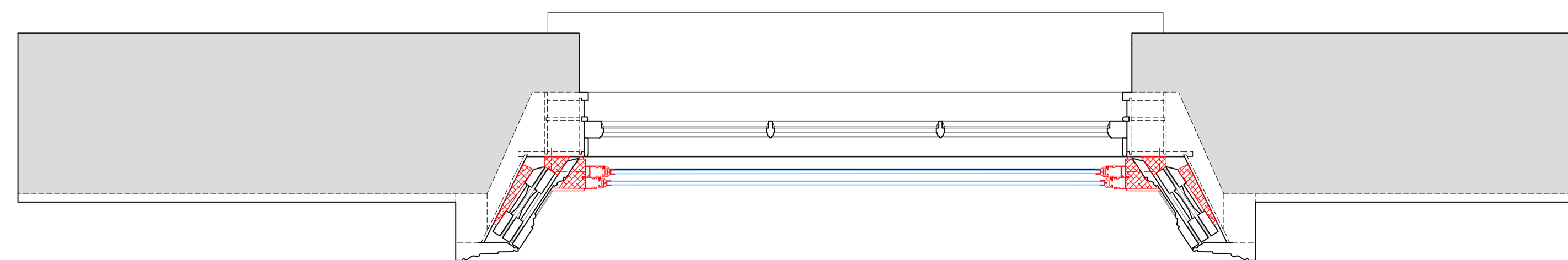

SECONDARY GLAZING SHOWN IN RED FOR VISUAL CLARITY ONLY

Revision	Date	Amendment
1.0	08-01-2018	Issued for listed building consent application
2.0	30-04-2018	Background 'slat ventilators' moved to the bottom of the window
3.0	16-08-2018	Additional information added

Do not reproduce this drawing without written permission
All dimensions are in millimetres unless stated otherwise

HS2

High Speed (HS2) Limited
25th Floor
One Canada Square
Canary Wharf
London E14 5AB

COSTAIN SKANSKA

Costain Skanska Joint Venture
1st Floor
The Podium
1 Eversholt Street
London NW1 2DN

Site Address:
28 Morningside Terrace, London NW1

Drawing Title:
Ground Floor Sitting Room: PROPOSED Secondary Glazing Details -
Sheet 5 of 8

Drawn by: GA Checked by: ED Presented by: as shown @ A1

Date: 16-08-2018 Drawing No: 2016-005-28MT-PR-GF-J-01 Revision: 3.0

Drawing Not For Construction

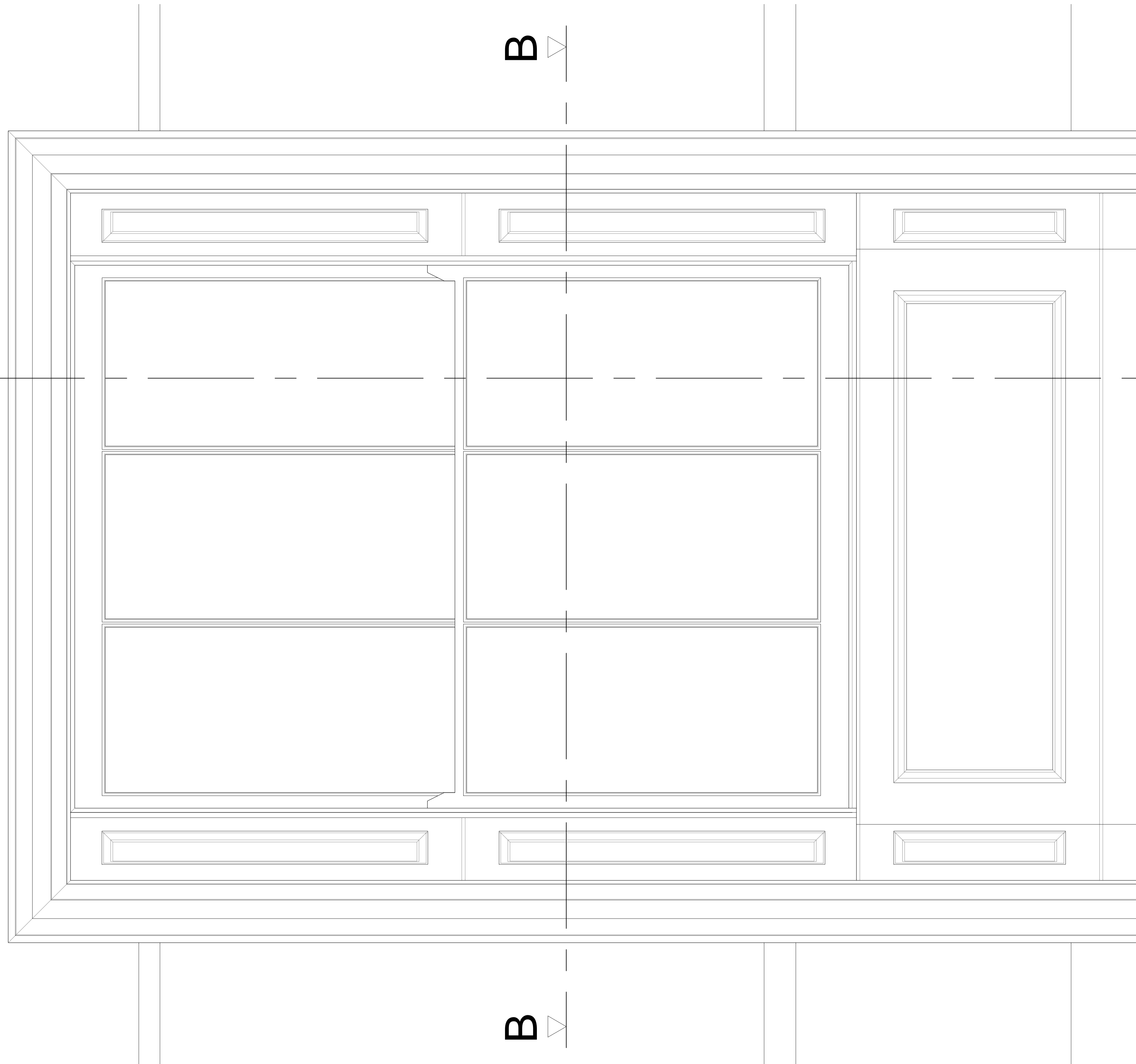

Internal Elevation with Shutters Open

Revision	Date	Assessment
1.0	08-01-2018	Issued for listed building consent application
2.0	16-08-2018	Additional information added

Do not reproduce this drawing without written permission
All dimensions are in millimetres unless stated otherwise

HS2

High Speed (HS2) Limited
25th Floor
One Canada Square
Canary Wharf
London E14 5AB

COSTAIN SKANSKA

Costain Skanska Joint Venture
1st Floor
The Podium
1 Eversholt Street
London NW1 2DN

Site Address: 28 Morningson Terrace, London NW1			
Drawing Title: Ground Floor Sitting Room: EXISTING Window Joinery Details - Sheet 2 of 8			
Support by: GA	Drawn by: PB	Checked by: ED	Preparation Scale: 1:5 @ A1
Date: 16-08-2018	Drawing No: 2016-005-28MT-EX-GF-J-02		Revision: 2.0

Drawing Not For Construction

A

B

A

B

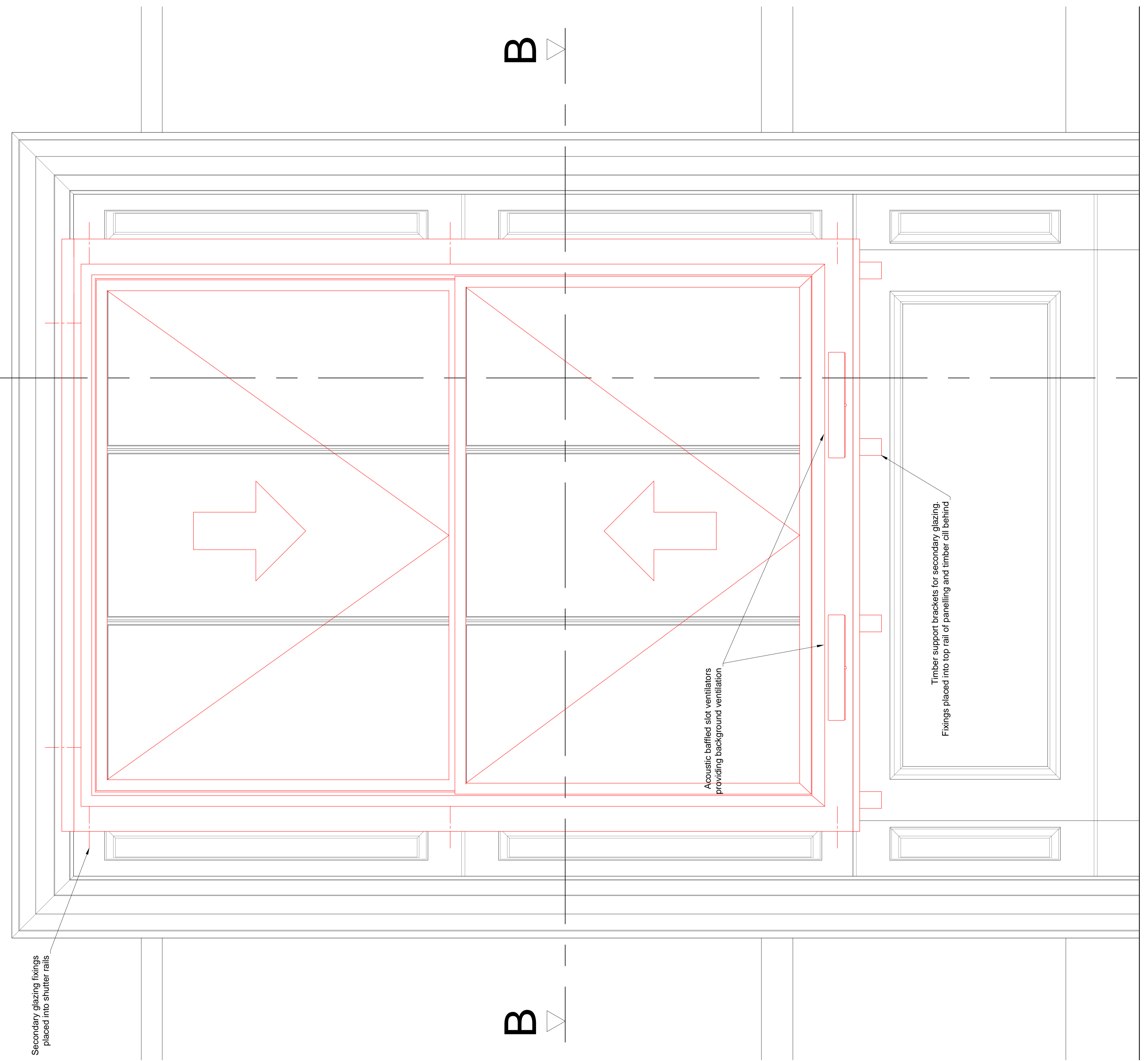

Secondary glazing fixings placed into shutter rails

Acoustic baffled slot ventilators providing background ventilation

Timber support brackets for secondary glazing. Fixings placed into top rail of panelling and timber cill behind

Internal Elevation with Shutters Open

Revision	Date	Amendment
1.0	08-01-2018	Issued for listed building consent application
2.0	30-04-2018	Background 'slot ventilators' moved to the bottom of the window
3.0	16-08-2018	Additional information added

Do not reproduce this drawing without written permission
All dimensions are in millimetres unless stated otherwise

HS2
High Speed (HS2) Limited
25th Floor
One Canada Square
Canary Wharf
London E14 5AB

COSTAIN SKANSKA
Costain Skanska Joint Venture
1st Floor
The Podium
1 Eversholt Street
London NW1 2DN

Site Address: 28 Mornington Terrace, London NW1			
Drawing Title: Ground Floor Sitting Room: PROPOSED Secondary Glazing Details - Sheet 6 of 8			
Drawn by: GA	Checked by: ED	Presented by: ED	Revision: 1:5 @ A1
Date: 16-08-2018	Drawing No: 2016-005-28MT-PR-GF-J-02		Revision: 3.0

Drawing Not For Construction

Section A-A through External Wall

Scale: 1:5

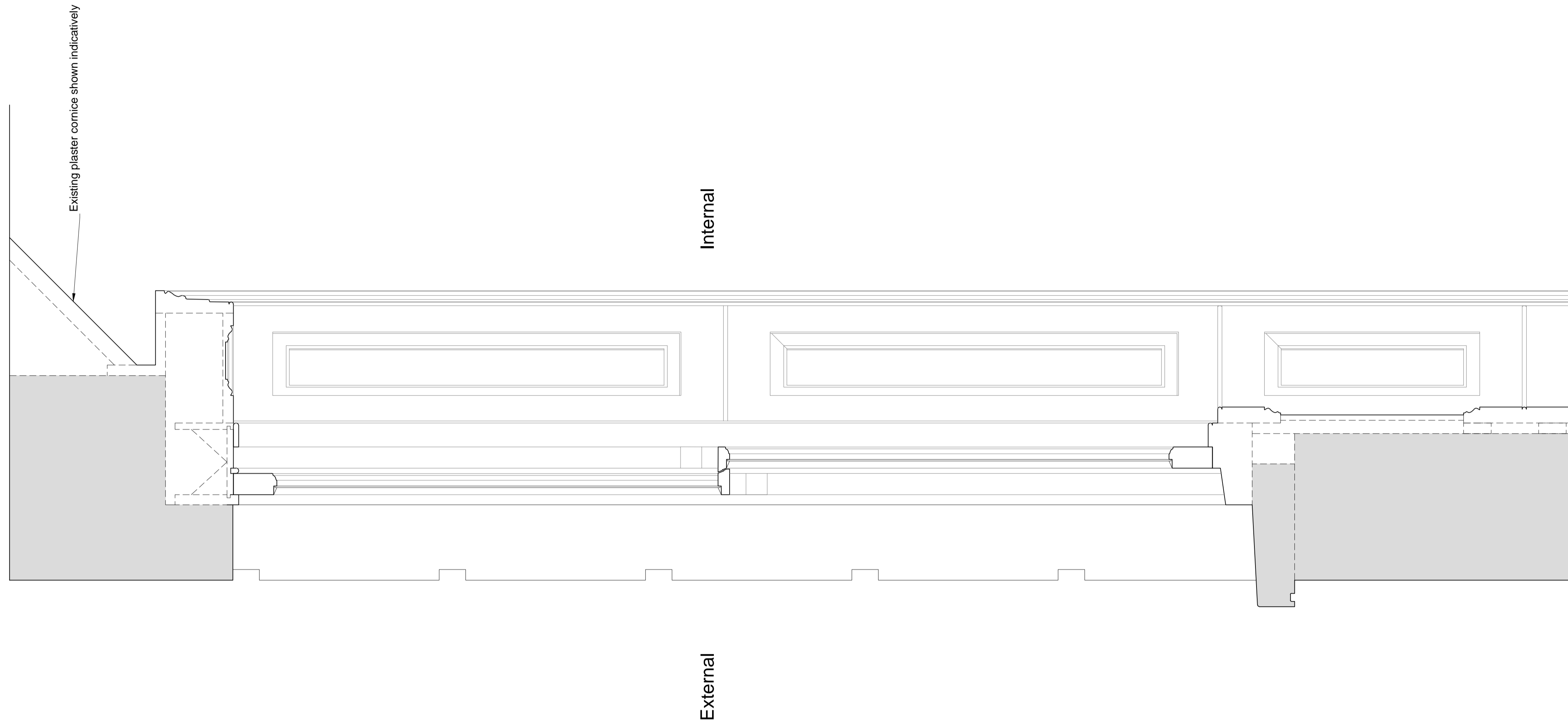

Revision	Date	Assessment
1.0	08-01-2018	Issued for listed building consent application
2.0	16-08-2018	Additional information added

Do not reproduce this drawing without written permission
All dimensions are in millimetres unless stated otherwise

HS2

High Speed (HS2) Limited
25th Floor
One Canada Square
Canary Wharf
London E14 5AB

COSTAIN SKANSKA

Costain Skanska Joint Venture
1st Floor
The Podium
1 Eversholt Street
London NW1 2DN

Site Address:
28 Morningside Terrace, London NW1

Drawing Title:
Ground Floor Sitting Room: EXISTING Window Joinery Details
Sheet 3 of 8

Prepared by: GA
Drawn by: PB
Checked by: ED
Presentation Scale: as shown @ A1

Date: 16-08-2018
Drawing No: 2016-005-28MT-EX-GF-J-03
Revision: 2.0

Drawing Not For Construction

Section A-A through External Wall
Scale: 1:5

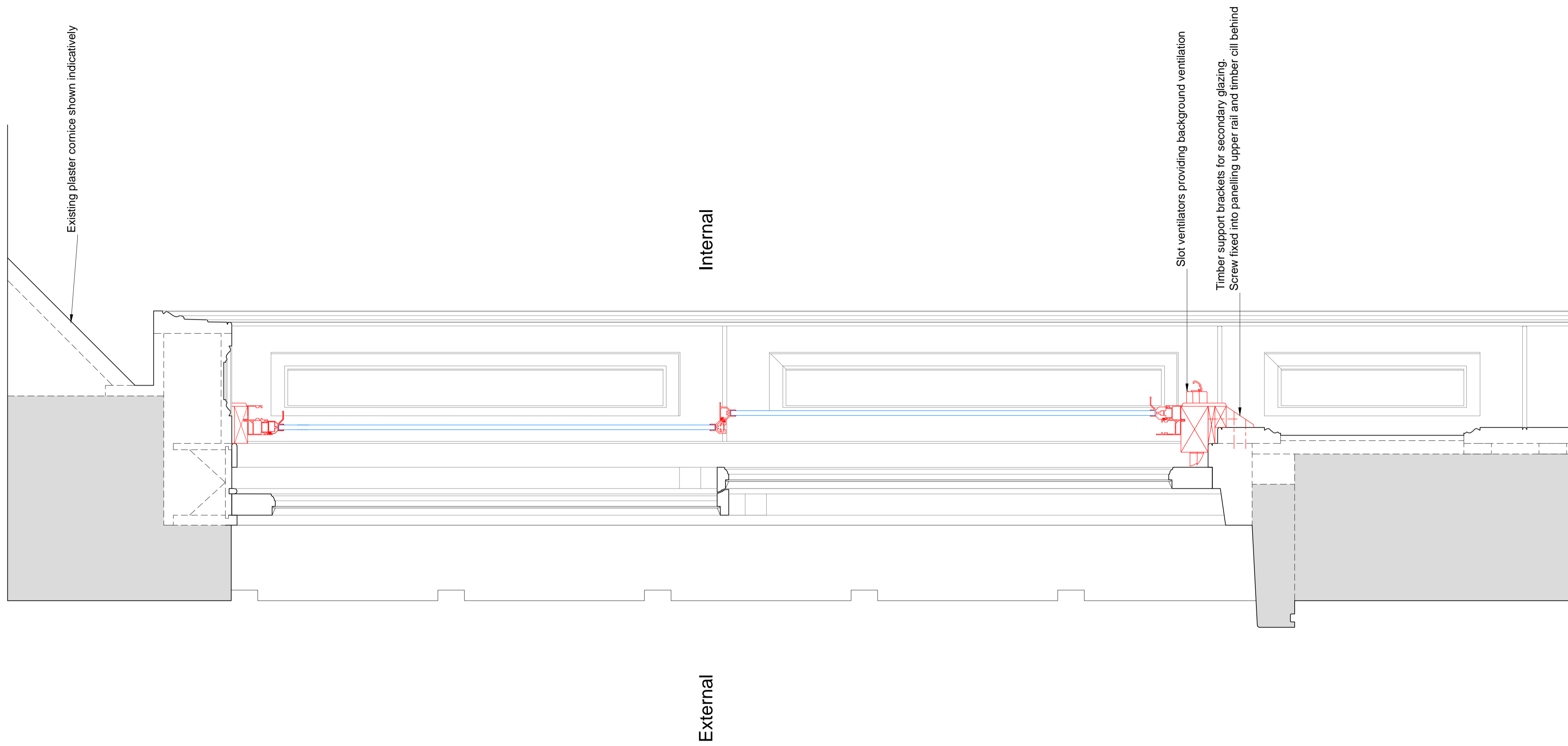

SECONDARY GLAZING SHOWN IN RED FOR VISUAL CLARITY ONLY

Revision	Date	Assessment
1.0	08-01-2018	Issued for listed building consent application
2.0	30-04-2018	Background 'slot ventilators' moved to the bottom of the window
3.0	16-08-2018	Additional information added

Do not reproduce this drawing without written permission
All dimensions are in millimetres unless stated otherwise



Site Address: 28 Morningside Terrace, London NW1			
Drawing Title: Ground Floor Sitting Room: PROPOSED Secondary Glazing Details Sheet 7 of 8			
Prepared by: GA	Drawn by: PB	Checked by: ED	Presentation Scale: as shown @ A1
Date: 16-08-2018	Drawing No: 2016-005-28MT-PR-GF-J-03	Revision: 3.0	

Drawing Not For Construction

Plan Section B-B
Scale: 1:5

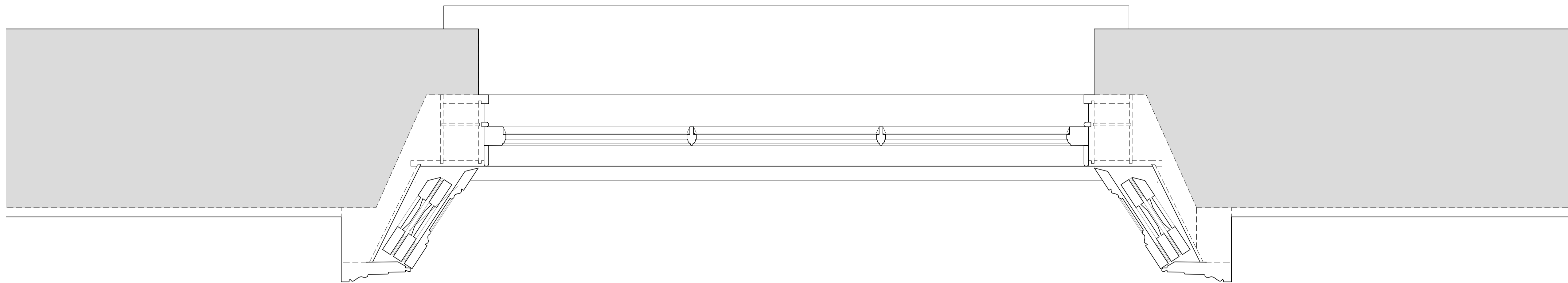

Revision	Date	Assessment
1.0	08-01-2018	Issued for listed building consent application
2.0	16-08-2018	Additional information added

Do not reproduce this drawing without written permission
All dimensions are in millimetres unless stated otherwise

HS2

High Speed (HS2) Limited
25th Floor
One Canada Square
Canary Wharf
London E14 5AB

COSTAIN SKANSKA

Costain Skanska Joint Venture
1st Floor
The Podium
1 Eversholt Street
London NW1 2DN

Site Address:
28 Morningside Terrace, London NW1

Drawing Title:
Ground Floor Sitting Room: EXISTING Window Joinery Details
Sheet 4 of 8

Drawn by: GA
Checked by: ED
Presented by: PB
Presentation Scale: as shown @ A1

Date: 16-08-2018
Drawing No: 2016-005-28MT-EX-GF-J-04
Revision: 2.0

Drawing Not For Construction

Plan Section B-B
Scale: 1:5

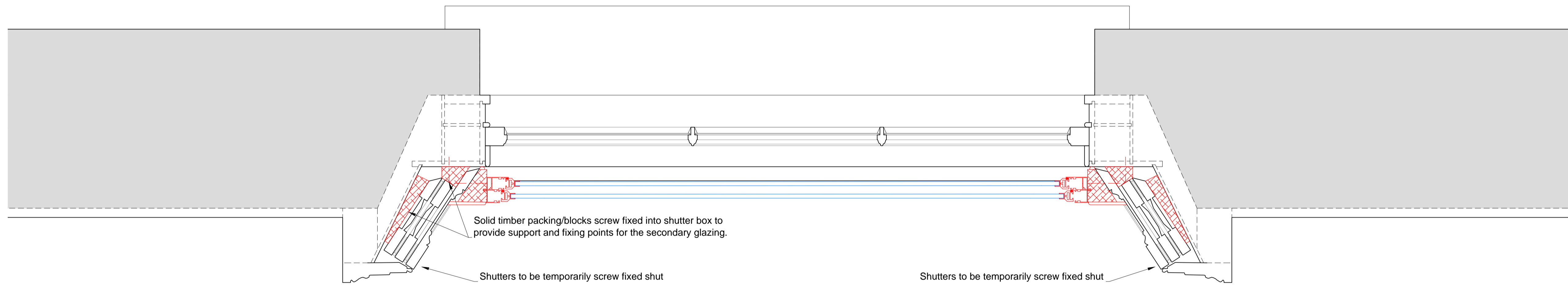

SECONDARY GLAZING SHOWN IN RED FOR VISUAL CLARITY ONLY

Revision	Date	Assessment
1.0	08-01-2018	Issued for listed building consent application
2.0	16-08-2018	Additional information added

Do not reproduce this drawing without written permission
All dimensions are in millimetres unless stated otherwise

HS2

High Speed (HS2) Limited
25th Floor
One Canada Square
Canary Wharf
London E14 5AB

COSTAIN SKANSKA

Costain Skanska Joint Venture
1st Floor
The Podium
1 Eversholt Street
London NW1 2DN

Site Address: 28 Morningson Terrace, London NW1			
Drawing Title: Ground Floor Sitting Room: PROPOSED Secondary Glazing Details Sheet 8 of 8			
Surveyed by: GA	Drawn by: PB	Checked by: ED	Preparation Scale: as shown @ A1
Date: 16-08-2018	Drawing No: 2016-005-28MT-PR-GF-J-04	Revision: 2.0	

Drawing Not For Construction

Internal Room Elevation

Scale: 1:10

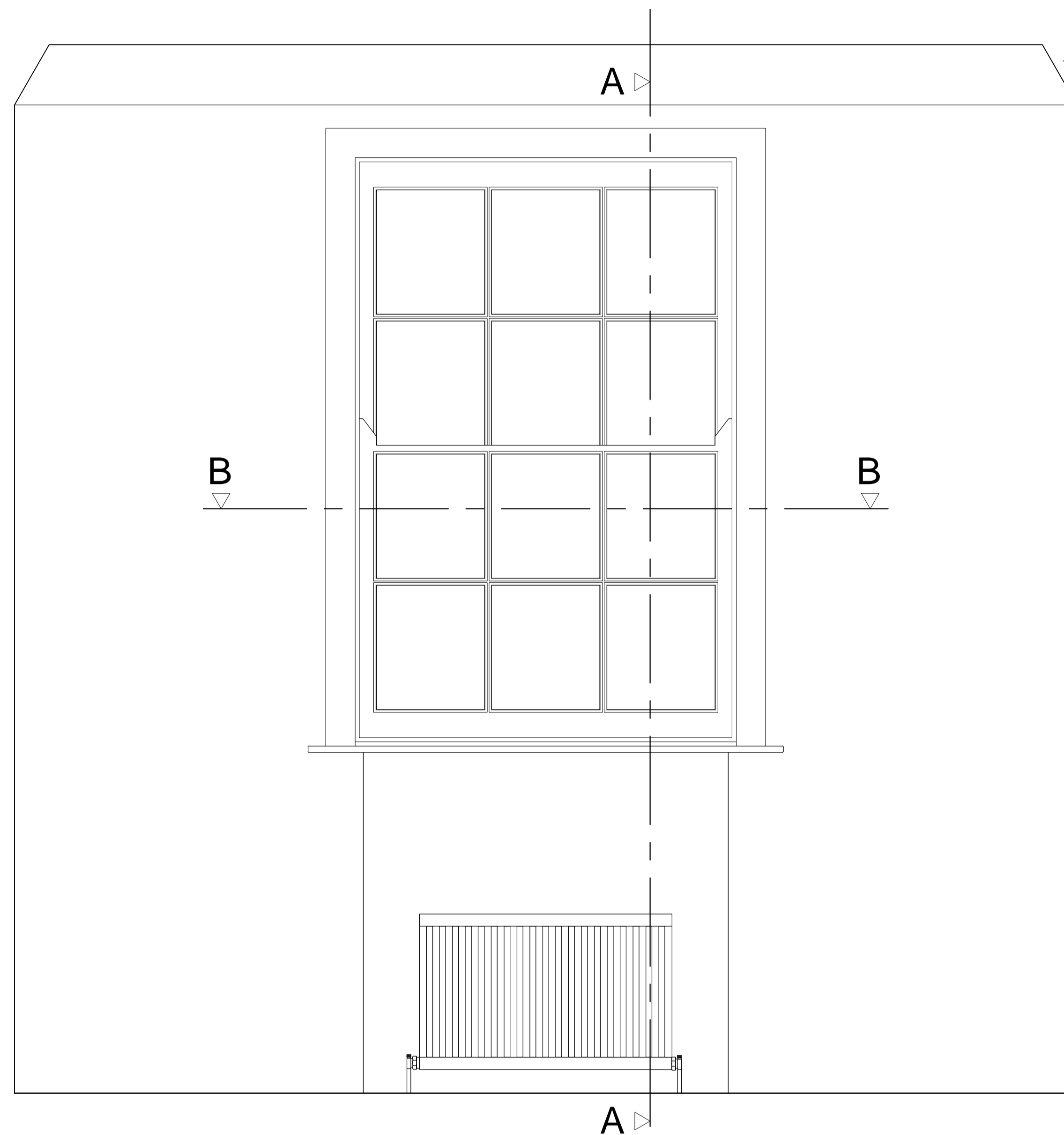

Ceiling cornice indicatively shown

Section A-A through External Wall

Scale: 1:10

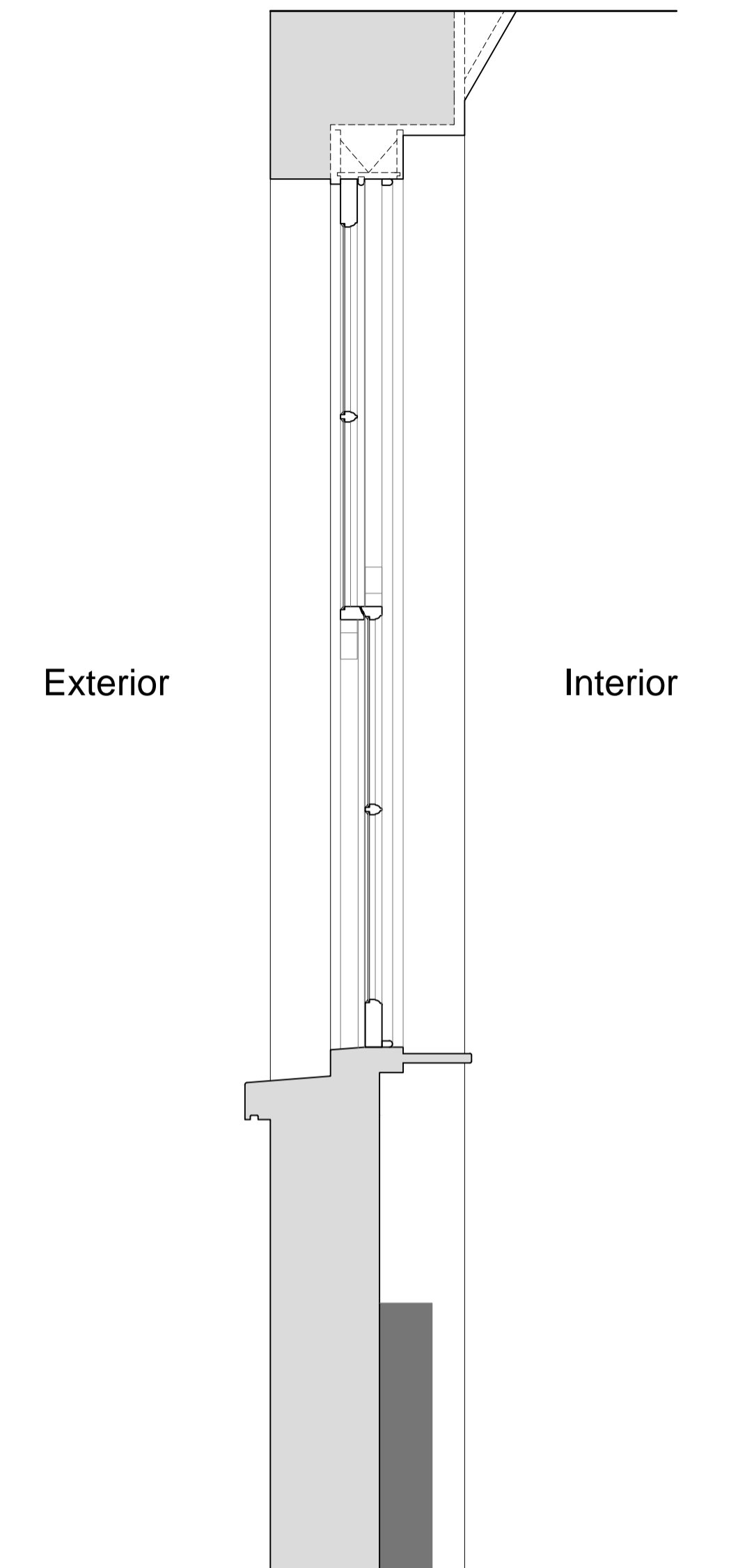

Plan Section B-B

Scale: 1:10

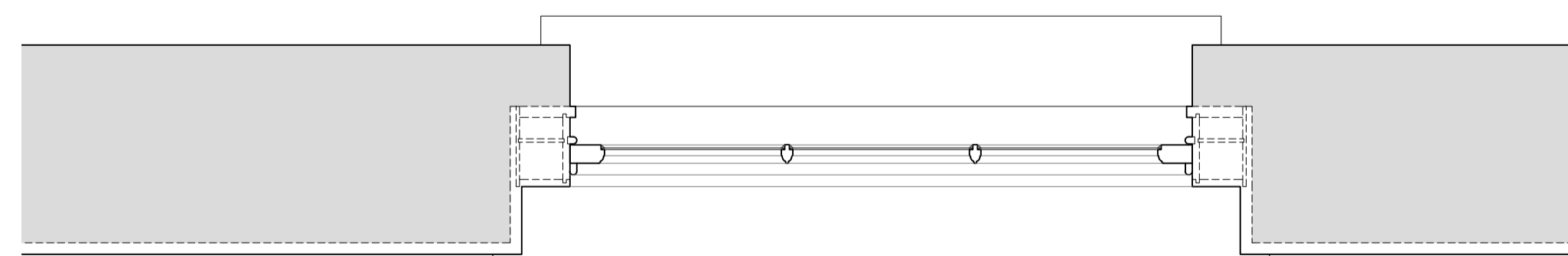

Revision	Date	Assessment
1.0	08-01-2018	Issued for listed building consent application
2.0	16-08-2018	Additional information added

Do not reproduce this drawing without written permission
All dimensions are in millimetres unless stated otherwise

HS2

High Speed (HS2) Limited
25th Floor
One Canada Square
Canary Wharf
London E14 5AB

COSTAIN SKANSKA

Costain Skanska Joint Venture
1st Floor
The Podium
1 Eversholt Street
London NW1 2DN

Site Address:
28 Morningside Terrace, London NW1

Drawing Title:
Ground Floor Bedroom: EXISTING Window Joinery Details -
Sheet 1 of 8

Drawn by: GA
Checked by: ED
Presented by: as shown @ A1

Date: 16-08-2018
Drawing No: 2016-005-28MT-EX-GF-J-05
Revision: 2.0

Drawing Not For Construction

Internal Room Elevation
Scale: 1:10

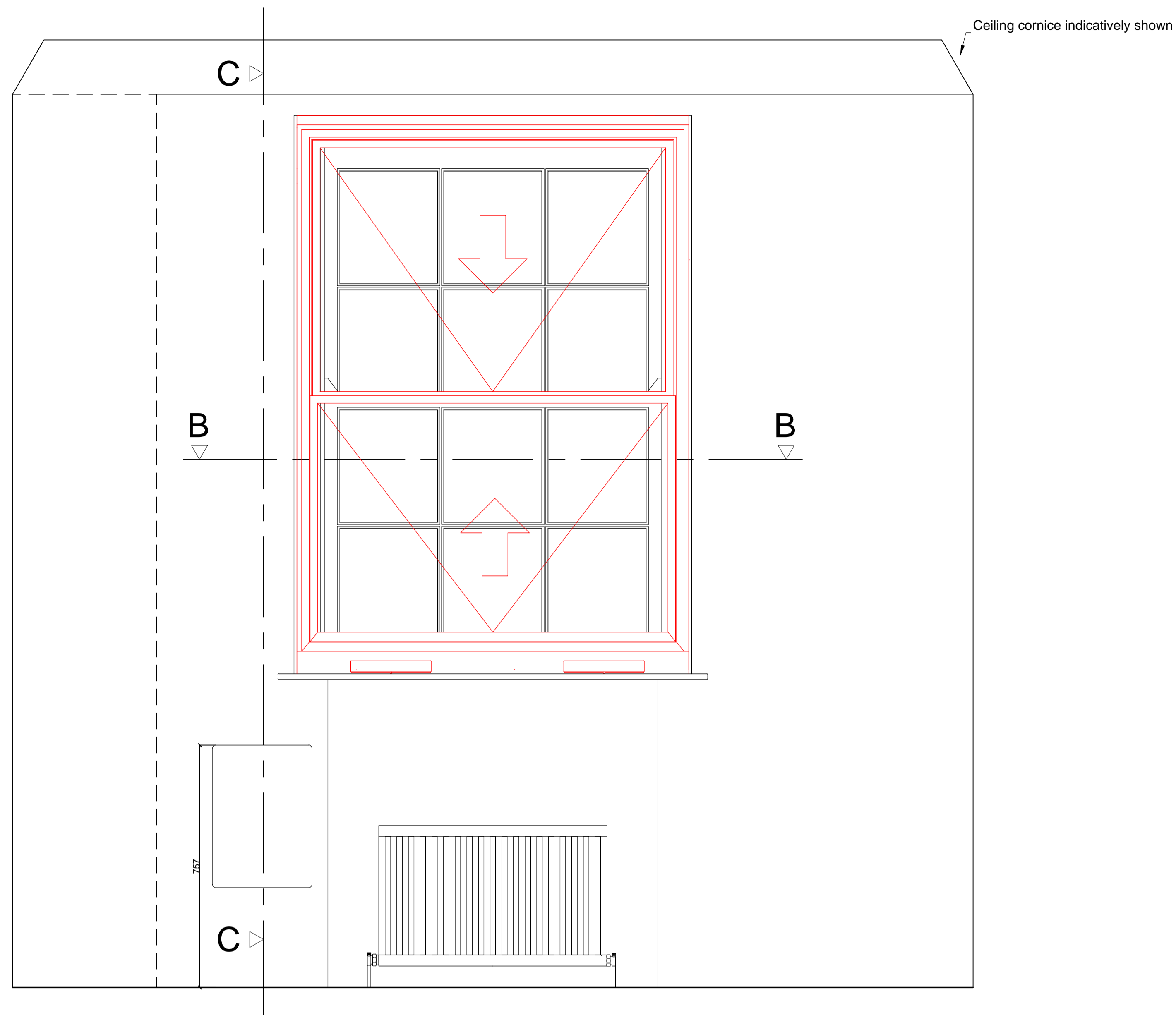

Section A-A through External Wall
Scale: 1:10

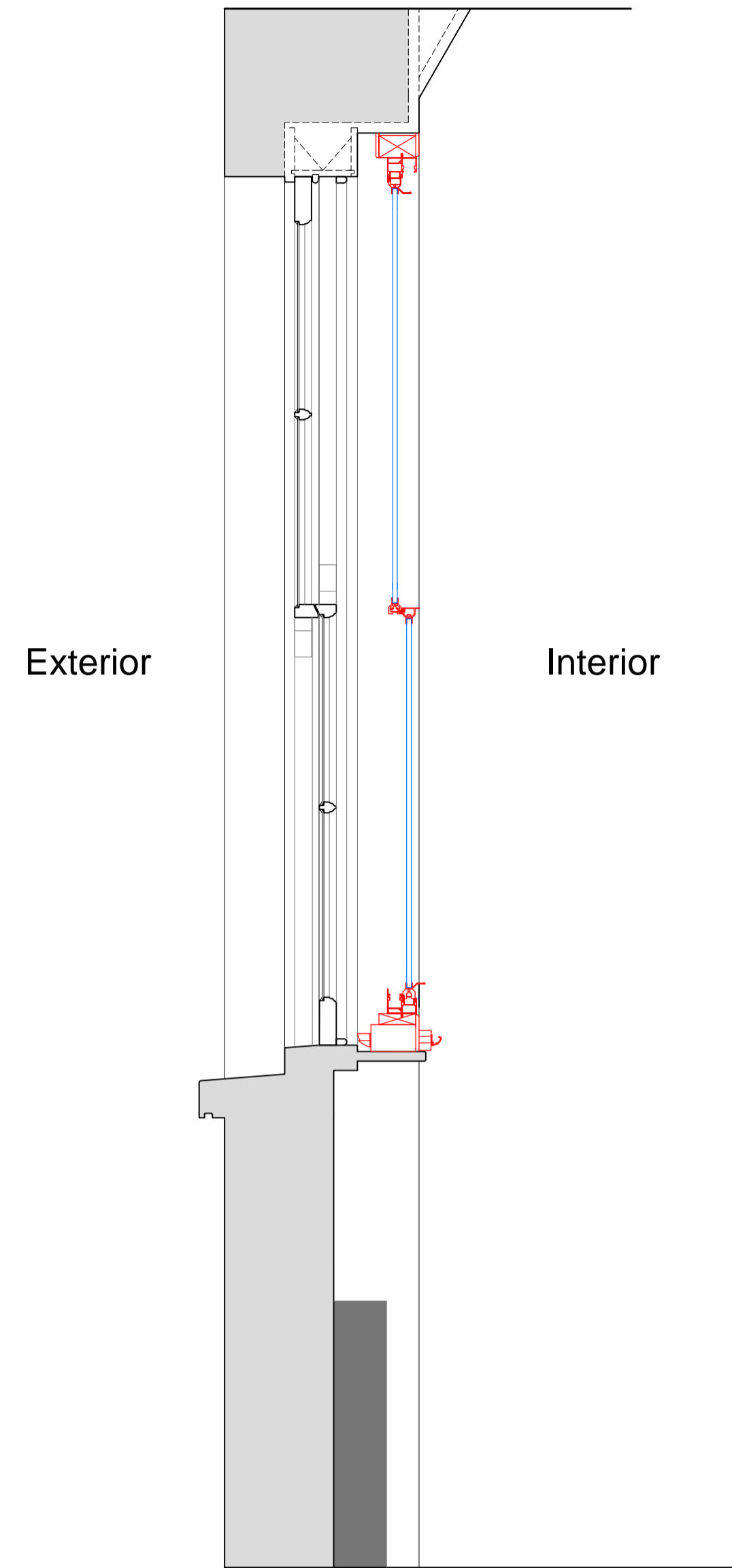

Section C-C through External Wall
Scale: 1:10

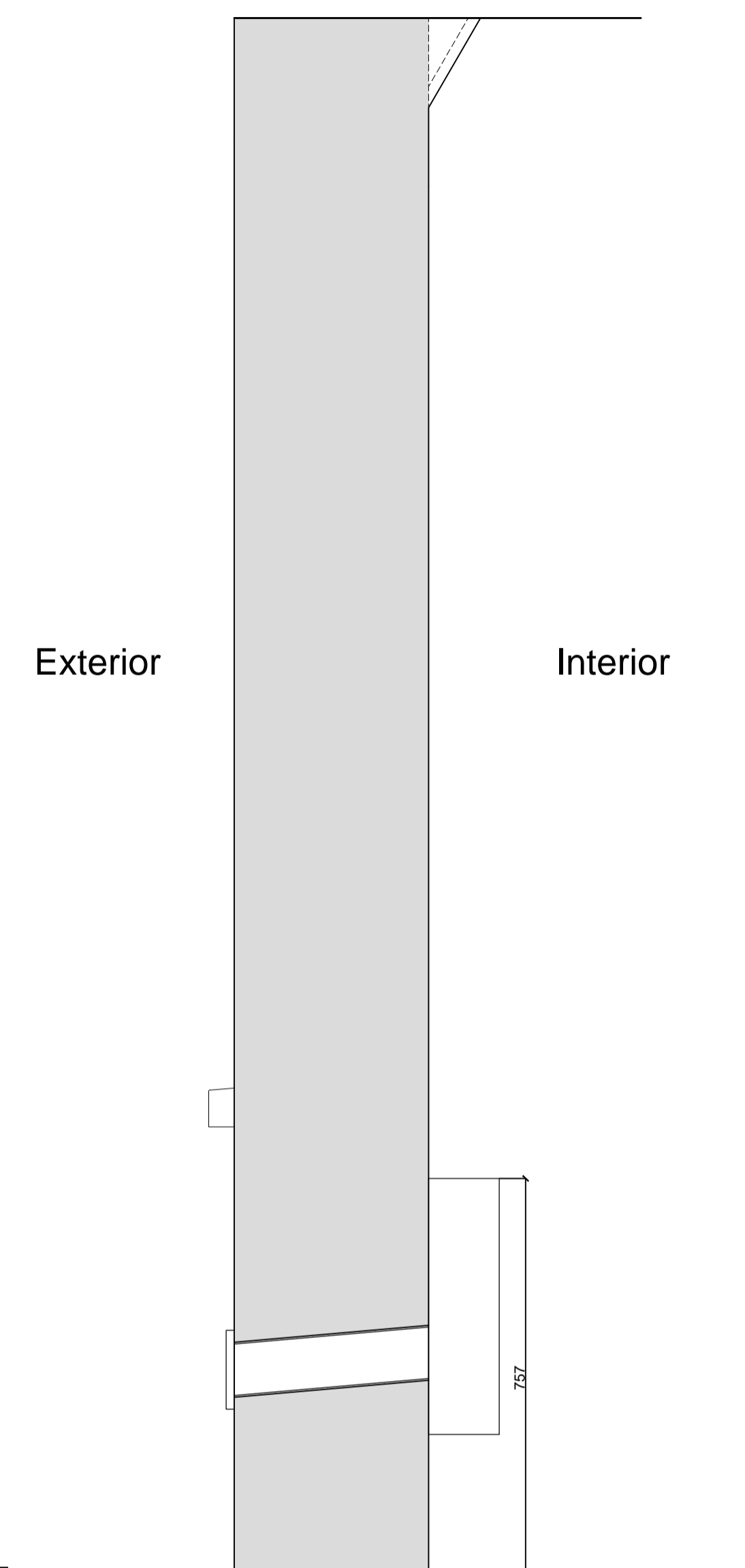

Plan Section B-B
Scale: 1:10

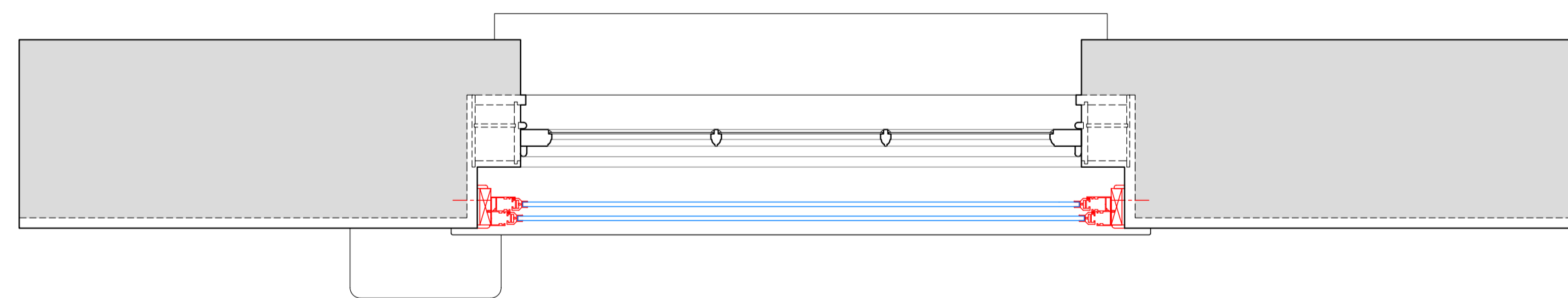

SECONDARY GLAZING SHOWN IN RED FOR VISUAL CLARITY ONLY

Revision	Date	Amendment
1.0	08-01-2018	Issued for listed building consent application
2.0	30-04-2018	Background 'slot ventilators' moved to the bottom of the window
3.0	07-06-2018	Mechanical input ventilator added to the rear wall
4.0	16-08-2018	Additional information added

Do not reproduce this drawing without written permission
All dimensions are in millimetres unless stated otherwise

HS2
High Speed (HS2) Limited
One Canada Square
Canary Wharf
London E14 5AB

COSTAIN SKANSKA
Costain Skanska Joint Venture
1st Floor
The Podium
1 Eversholt Street
London NW1 2DN

Site Address			
28 Mornington Terrace, London NW1			
Drawing Title			
Ground Floor Bedroom: PROPOSED Secondary Glazing Details - Sheet 5 of 8			
Consultant		Presenter/Scale	
GA	PB	ED	as shown @ A1
Date	Drawing No.	Revision	
16-08-2018	2016-005-28MT-PR-GR-J-05	4.0	

Drawing Not For Construction

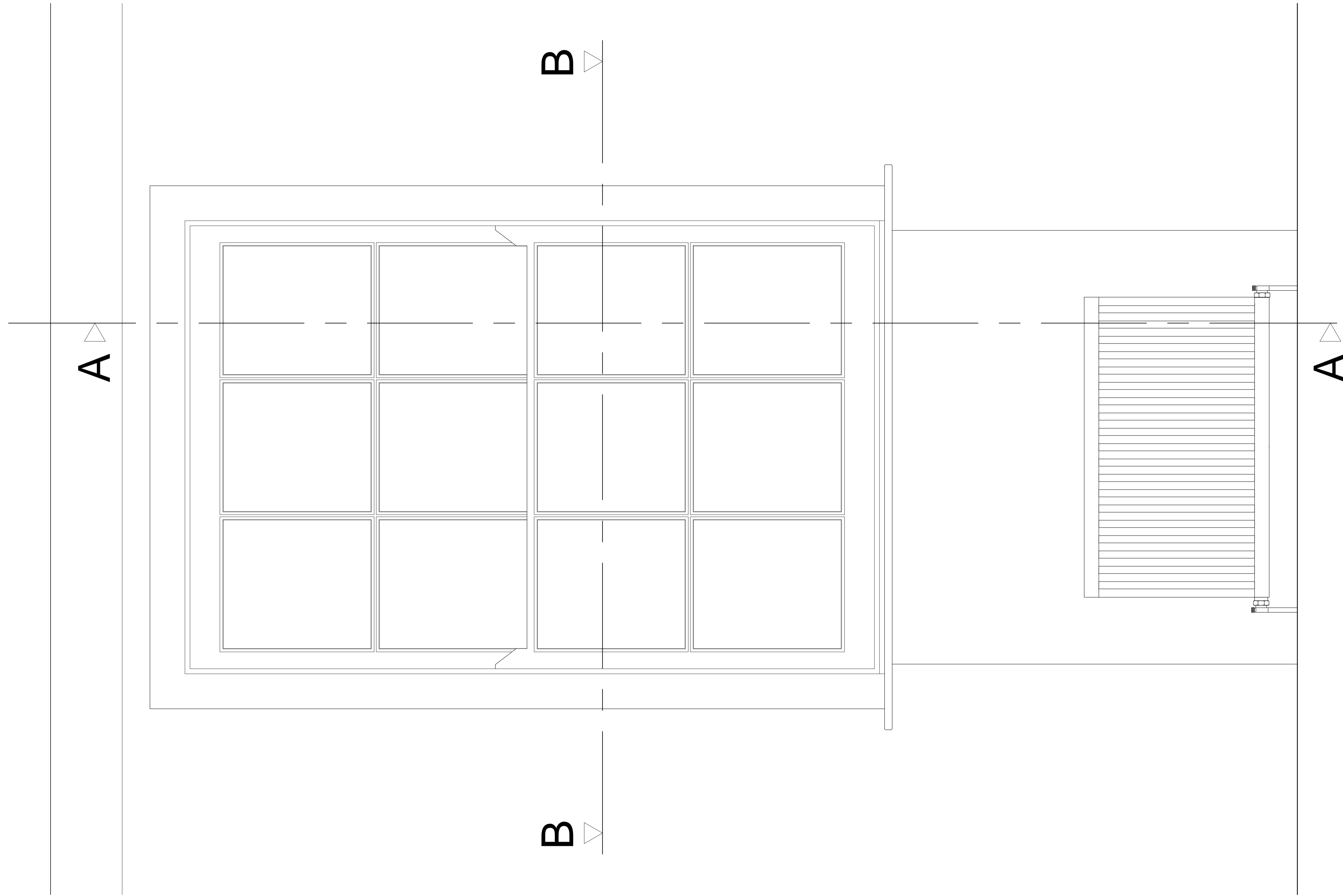

Revision	Date	Assessment
1.0	08-01-2018	Issued for listed building consent application
2.0	16-08-2018	Additional information added

Do not reproduce this drawing without written permission
All dimensions are in millimetres unless stated otherwise

HS2

High Speed (HS2) Limited
25th Floor
One Canada Square
Canary Wharf
London E14 5AB

COSTAIN SKANSKA

Costain Skanska Joint Venture
1st Floor
The Podium
1 Eversholt Street
London NW1 2DN

Site Address:
28 Morningside Terrace, London NW1

Drawing Title:
Ground Floor Bedroom: EXISTING Window Joinery Details -
Sheet 2 of 8

Drawn by: GA
Checked by: ED
Prepared by: PB
Presentation Scale: 1:5 @ A1

Date: 16-08-2018
Drawing No: 2016-005-28MT-EX-GF-J-06
Revision: 2.0

Drawing Not For Construction

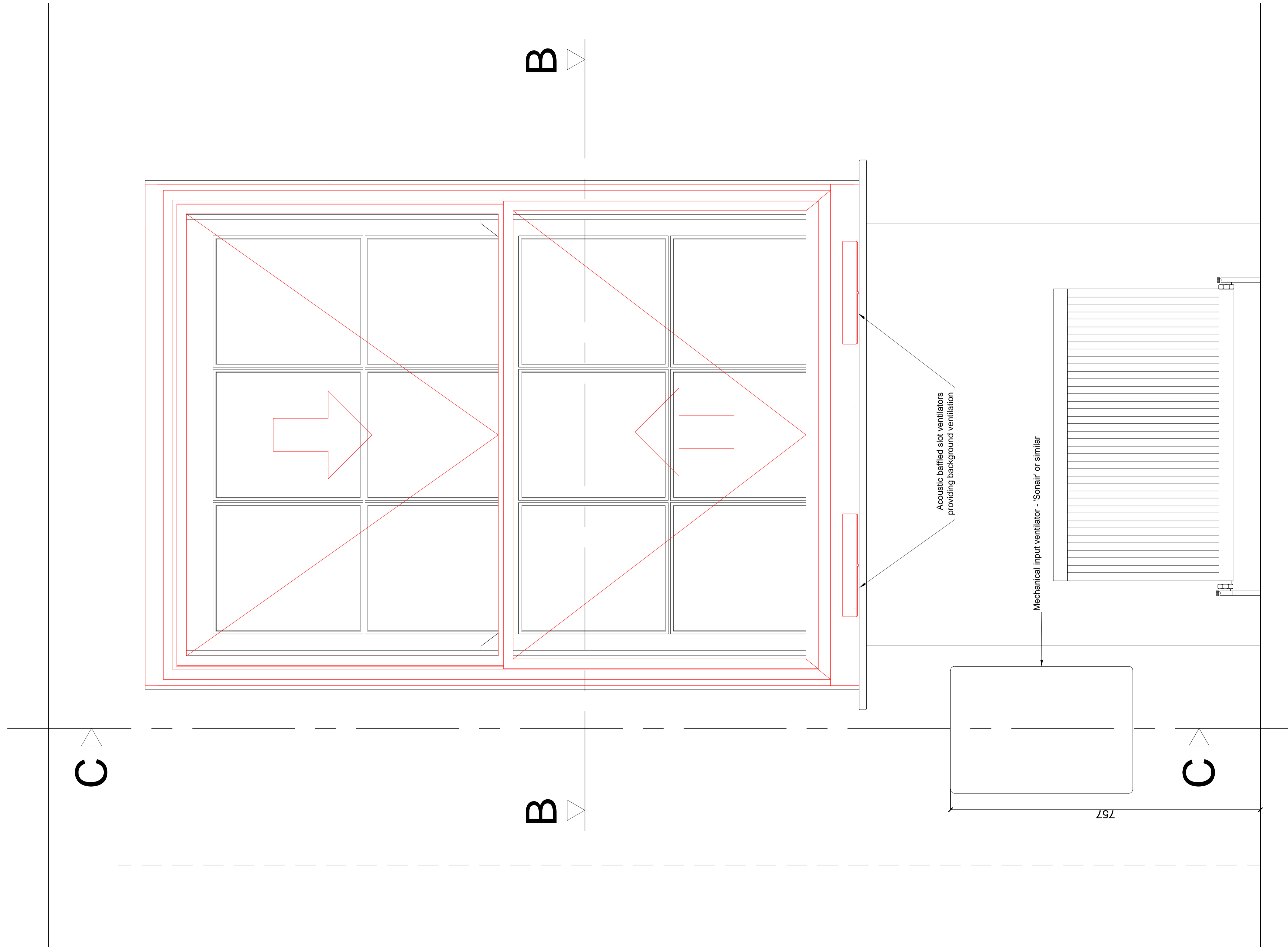

SECONDARY GLAZING SHOWN IN RED FOR VISUAL CLARITY ONLY

Revision	Date	Assessment
1.0	08-01-2018	Issued for listed building consent application
2.0	30-04-2018	Background 'slot ventilators' moved to the bottom of the window
3.0	07-06-2018	Mechanical input ventilator added to the rear wall
4.0	16-08-2018	Additional information added

Do not reproduce this drawing without written permission
All dimensions are in millimetres unless stated otherwise

HS2
High Speed (HS2) Limited
25th Floor
One Canada Square
Canary Wharf
London E14 5AB

COSTAIN SKANSKA
Costain Skanska Joint Venture
1st Floor
The Podium
1 Eversholt Street
London NW1 2DN

Site Address:
28 Mornington Terrace, London NW1

Drawing Title:
Ground Floor Bedroom: PROPOSED Secondary Glazing Details -
Sheet 6 of 8

Drawn by: GA
Checked by: PB
ED
Presentation Scale: 1:5 @ A1

Date: 16-08-2018
Drawing No: 2016-005-28MT-PR-GF-J-06
Revision: 4.0

Drawing Not For Construction

Section A-A through External Wall

Scale: 1:5

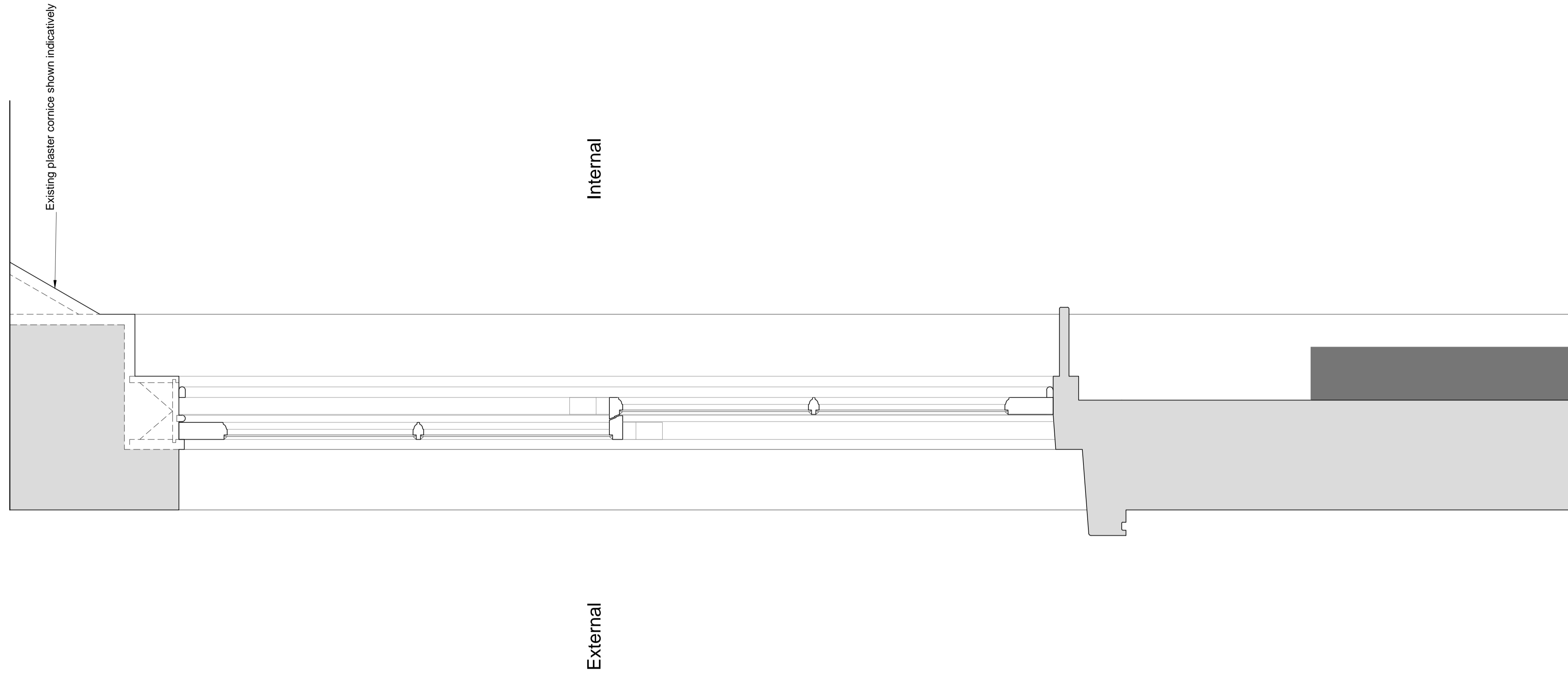

Revision	Date	Assessment
1.0	08-01-2018	Issued for listed building consent application
2.0	16-08-2018	Additional information added

Do not reproduce this drawing without written permission
All dimensions are in millimetres unless stated otherwise

HS2

High Speed (HS2) Limited
25th Floor
One Canada Square
Canary Wharf
London E14 5AB

COSTAIN SKANSKA

Costain Skanska Joint Venture
1st Floor
The Podium
1 Eversholt Street
London NW1 2DN

Site Address:
28 Morningside Terrace, London NW1

Drawing Title:
Ground Floor Bedroom: EXISTING Window Joinery Details -
Sheet 3 of 8

Drawn by: GA
Checked by: ED
Prepared by: PB
Presentation Scale: 1:5 @ A1

Date: 16-08-2018
Drawing No: 2016-005-28MT-EX-GF-J-07
Revision: 2.0

Drawing Not For Construction

Section C-C through External Wall & Mechanical Input Ventilator
Scale: 1:5

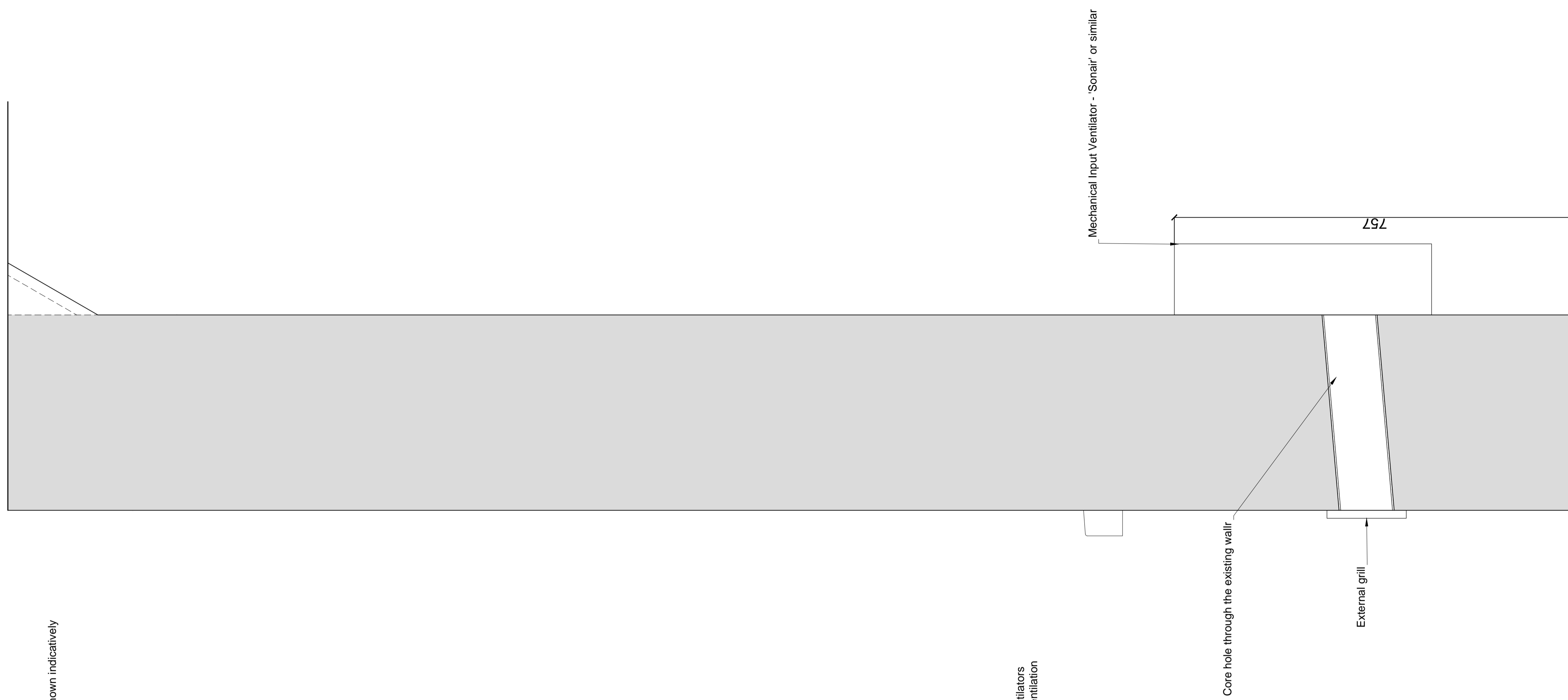

Section A-A through External Wall
Scale: 1:5

SECONDARY GLAZING SHOWN IN RED FOR VISUAL CLARITY ONLY

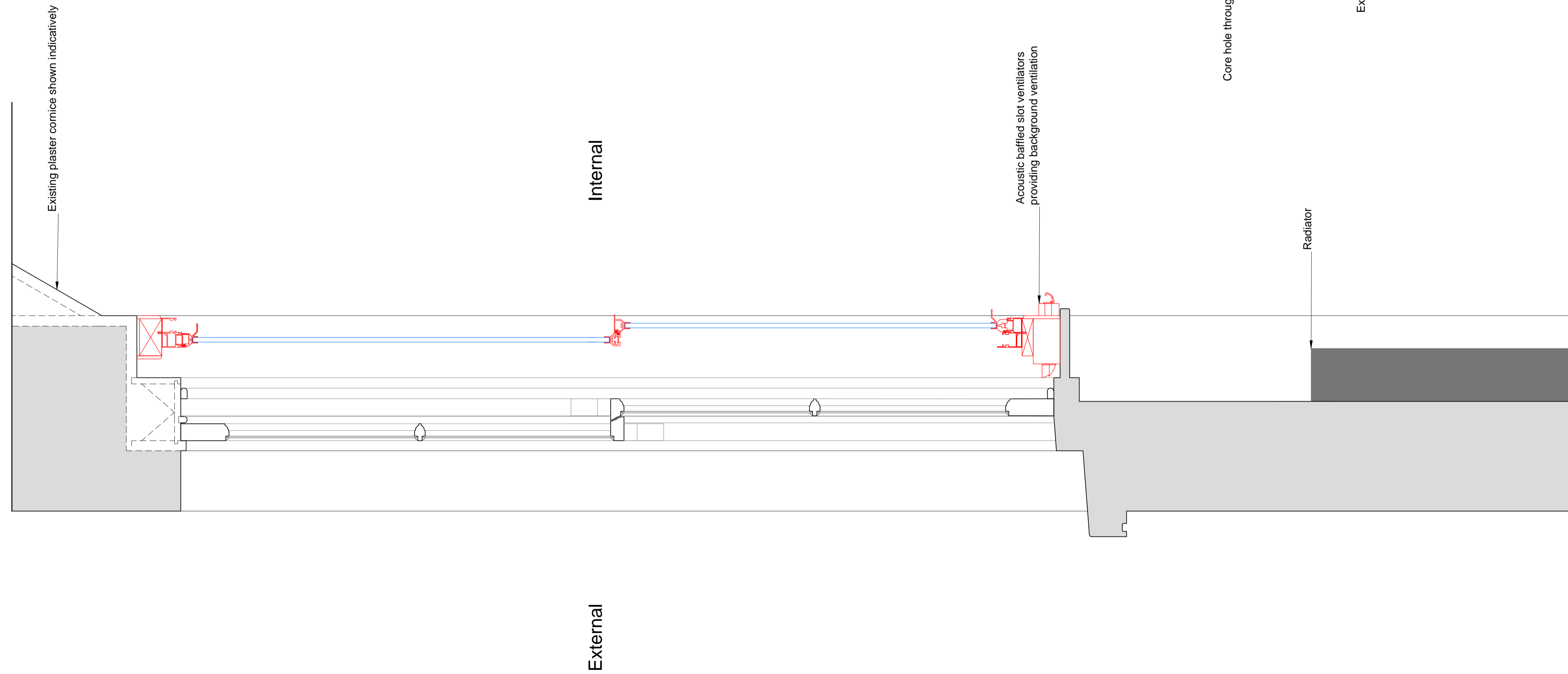

Revision	Date	Assessment
1.0	08-01-2018	Issued for listed building consent application
2.0	30-04-2018	Background 'slot ventilators' moved to the bottom of the window
3.0	07-06-2018	Mechanical input ventilator added to the rear wall
4.0	16-08-2018	Additional information added

Do not reproduce this drawing without written permission
All dimensions are in millimetres unless stated otherwise

HS2

High Speed (HS2) Limited
25th Floor
One Canada Square
Canary Wharf
London E14 5AB

COSTAIN SKANSKA

Costain Skanska Joint Venture
1st Floor
The Podium
1 Eversholt Street
London NW1 2DN

Site Address:
28 Morningside Terrace, London NW1

Drawing Title:
Ground Floor Bedroom: PROPOSED Secondary Glazing Details -
Sheet 7 of 8

Drawn by: GA
Checked by: ED
Preparation Scale: 1:5 @ A1

Date: 16-08-2018
Drawing No: 2016-005-28MT-PR-GF-J-07
Revision: 4.0

Drawing Not For Construction

Plan Section B-B
Scale: 1:5

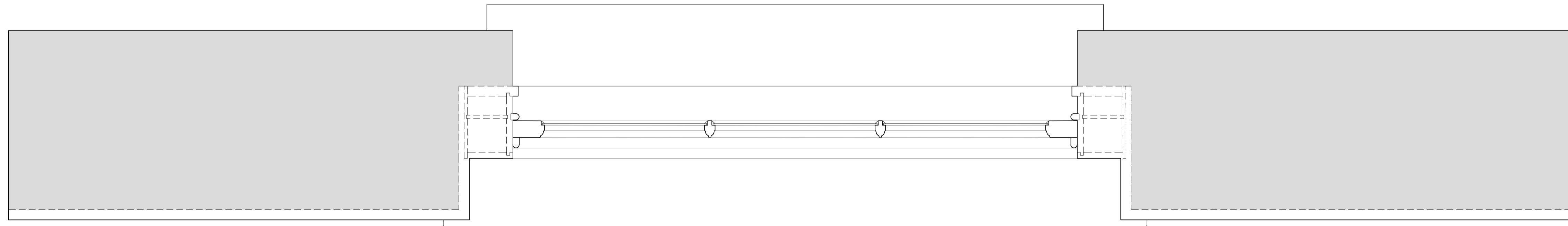

Revision	Date	Assessment
1.0	08-01-2018	Issued for listed building consent application
2.0	16-08-2018	Additional information added

Do not reproduce this drawing without written permission
All dimensions are in millimetres unless stated otherwise

HS2
High Speed (HS2) Limited
25th Floor
One Canada Square
Canary Wharf
London E14 5AB

COSTAIN SKANSKA
Costain Skanska Joint Venture
1st Floor
The Podium
1 Eversholt Street
London NW1 2DN

Site Address:
28 Morningside Terrace, London NW1

Drawing Title:
Ground Floor Bedroom: EXISTING Window Joinery Details
Sheet 4 of 8

Drawn by: GA
Checked by: ED
Presentation Scale: as shown @ A1

Date: 16-08-2018
Drawing No: 2016-005-28MT-EX-GF-J-08
Revision: 2.0

Drawing Not For Construction

Plan Section B-B
Scale: 1:5

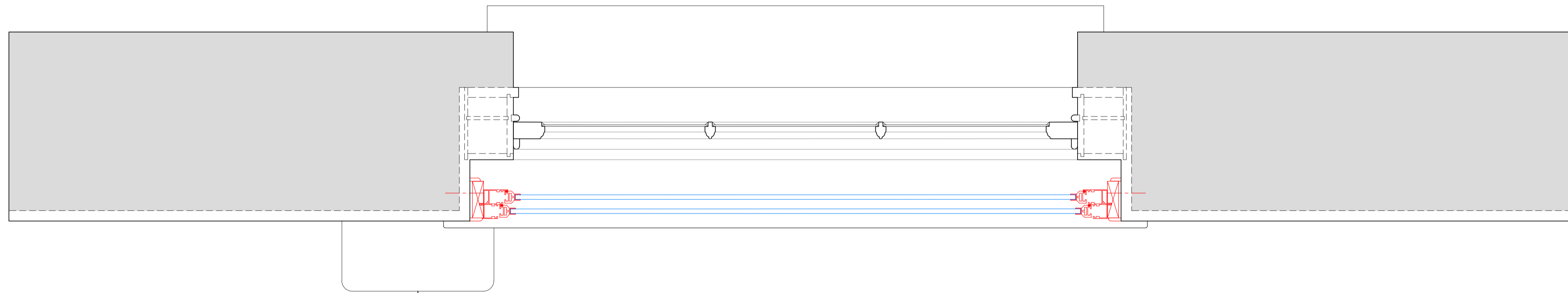

Mechanical input ventilator - 'Sonair' or similar

SECONDARY GLAZING SHOWN IN RED FOR VISUAL CLARITY ONLY

Revision	Date	Assessment
1.0	08-01-2018	Issued for listed building consent application
2.0	07-06-2018	Mechanical input ventilator added to the rear wall
3.0	16-08-2018	Additional information added

Do not reproduce this drawing without written permission
All dimensions are in millimetres unless stated otherwise

HS2

High Speed (HS2) Limited
25th Floor
One Canada Square
Canary Wharf
London E14 5AB

COSTAIN SKANSKA

Costain Skanska Joint Venture
1st Floor
The Podium
1 Eversholt Street
London NW1 2DN

Site Address:
28 Morningside Terrace, London NW1

Drawing Title:
Ground Floor Bedroom: PROPOSED Secondary Glazing Details
Sheet 8 of 8

Drawn by: GA
Checked by: ED
Presented by: as shown @ A1

Date: 16-08-2018
Drawing No: 2016-005-28MT-PR-GF-J-08
Revision: 3.0

Drawing Not For Construction