

## WINDOW AND DOOR SYSTEMS

AluK is a leader in the design and manufacture of window and door systems. Through our continual innovation we have developed some of the most aesthetically pleasing and performance driven products available in the UK and across the world.

We provide a complete range of systems to suit the needs of any project, commercial or residential, providing the flexibility, style, security and performance that designers are looking for when specifying glazing and entrance solutions. Manufactured to the highest standards using aluminium, our doors and windows are inherently strong, lightweight and sustainable.

Our unique profiles have been designed to meet and exceed the performance standards expected in modern building design, whilst also providing the aesthetic appeal designers are looking for. A range of design features and functions enable specifiers to choose the product that suits the needs and design of their project, whilst being assured of the quality and performance that is integral to all our innovative building systems.

AluK window and door systems are available in a wide variety of configurations, as well as varying levels of performance and frame profiles, providing the solution to

meet your project requirements. We are also able to work with specifiers to provide bespoke solution for particular projects, where specific performance demands are required.

Safe and very secure, AluK window and door systems are certified under the Secured by Design scheme, managed by the UK Association of Chief Police Officers, and include high quality multi-point locking mechanisms and a range of other security features. Combined with the inherent strength of aluminium, our doors are some of the most secure available on the market.

Systems are available in a range of standard colours as well as any RAL colour to order. This can be single or dual colour, providing the option to have a different colour inside and out. A wide range of complementary fittings are also available to complete the desired look.



**WINDOW AND DOOR SYSTEMS**



## 72BW/BD HI WINDOW AND DOOR SYSTEM

This three chamber aluminium window and door system has been designed to offer the highest levels of performance, alongside the flexibility to tailor configurations to your requirements.

The 72BW/BD HI aluminium window and door system incorporates our patented Spidertechnology® ABS strips that allow you to achieve high thermal insulation without common expensive system adjustments. The system has been certified under the Secured by Design scheme and incorporates high security multipoint-locking systems and a range of window and door furniture.

### DESIGN FEATURES

- Three chamber window system for exceptional stability
- Integrated system
- Both aluminium and PVC groove hardware available
- Wide range of styles and configurations to choose from
- A variety of finishes and detailing are available to suit your project
- Customisable components to reach desired thermal performance specification
- All certified under Secured by Design scheme

### OPTIONS

- EPDM insulation can be inserted to create a multi-chambered "insulation block" between frame and vent profile and prevent localised convection
- A continuous insulation strip in PE foam can be introduced between the glazing and aluminium profile during glazing to significantly reduce heat loss
- All opening vents can be restricted to 100mm openings
- Full range of hardware and security locking mechanisms available
- Glazing sizes of 25mm – 65mm
- Available in single or dual colour options including anodised finishes

### WINDOW CONFIGURATIONS

- Single & Double Casement
- Side Hung & Bottom Hung (Open In)
- Tilt/Turn & Turn/Tilt
- Tilt & Slide
- Vertical & Horizontal Pivots
- Parallel Opening Vents
- Lifetime Homes (LTH)

### DOOR CONFIGURATIONS

- Single Doors (Open In)
- Single Doors (Open Out)
- Double Doors (Open In)
- Double Doors (Open Out)

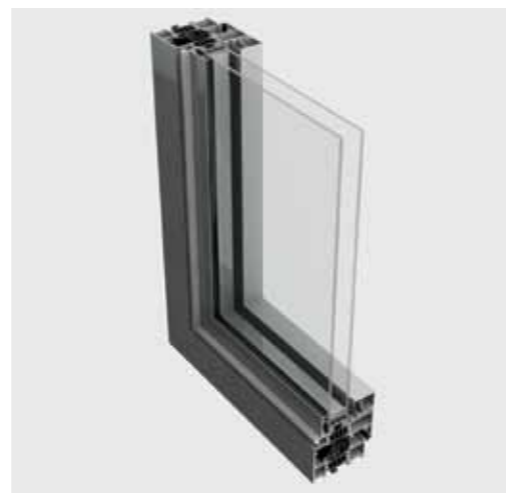

## 72BW/BD HI WINDOW AND DOOR SYSTEM TECHNICAL SPECIFICATIONS

The 72BW/BD HI window and door system provides complete flexibility alongside the ultimate in performance to meet the needs of the most demanding project. Available in a wide range of configurations, finishes and colours, the system can be adapted

and configured to complement the design of your building. All systems have received 3rd party certification under the BSI Kitemark scheme.

SPECIFICATIONS	OUTWARD OPENING	INWARD OPENING	PIVOT	PARALLEL OPENING VENT	SINGLE & DOUBLE DOOR
<b>Performance &amp; Accreditation</b>					
U-Value (Double Glazing)*	1.6 W/m²K	1.4 W/m²K	1.6 W/m²K	1.4 W/m²K	1.6 W/m²K
U-Value (Triple Glazing)**	1.3 W/m²K	1.0 W/m²K	1.3 W/m²K	1.0 W/m²K	1.2 W/m²K
Window Energy Rating (WER)	npd	npd	npd	npd	npd
Green Guide Rating	B Rated	B Rated	B Rated	B Rated	B Rated
Acoustic Performance (dB)	Rw (C;Ctr) 40 (-2;-6) dB	Rw (C;Ctr) 40 (-2;-6) dB	npd	npd	Rw (C;Ctr) 35 (-2;-5) dB
Air Tightness (Pa)	Class 4	Class 4	Class 4	Class 4	Class 4
Water Tightness (Pa)	Class E2000	Class 7a	Class 6a	Class E1950	Class E750
Wind Load (Pa)	Class 4	Class 4	Class 4	Class E2400	Class 4
Security	EN 1627	EN 1627	EN 1627	npd	npd
Secured By Design	Yes	Yes	No	No	No
<b>Configurations</b>					
<b>Opening</b>	Open Out	Open In	Open Out	Open Out	Open In & Open Out
Top Hung	●	--	--	--	--
Side Hung	●	--	--	--	--
Bottom Hung	●	●	--	--	--
Fixed Light	●	●	●	●	●
Mullight	●	--	--	--	--
Tilt & Turn	--	●	--	--	--
Life Time Homes (LTH)	--	●	--	--	--
Tilt & Slide	--	●	--	--	--
Vertical Pivot	--	--	●	--	--
Horizontal Pivot	--	--	●	--	--
Parallel Opening Vent	--	--	--	●	--
<b>Size Limits</b>					
<b>Max Vent Weight</b>	--	--	--	--	100 Kg
Top Hung	90 Kg	--	--	--	--
Side Hung	130 Kg	--	--	--	--
Bottom Hung	90 Kg	100 Kg	--	--	--
Fixed Light	250 Kg	--	--	250 Kg	--
Tilt & Turn	--	130 Kg	--	--	--
Life Time Homes (LTH)	--	100 Kg	--	--	--
Tilt & Slide	--	100 Kg	--	--	--
Vertical Pivot	--	--	120 Kg	--	--
Horizontal Pivot	--	--	180 Kg	--	--
Parallel Opening Vent	--	--	--	200 Kg	--
<b>System Features</b>					
Frame Options	72mm	72mm	72mm	105mm	72mm
Dual Colour Option	●	●	●	●	●
Multi-Point Locking	●	●	●	●	●
Glazing Options	Internal	Internal	Internal	Internal	Internal
Glazing Thickness	13mm - 57mm	18mm - 66mm	13mm - 57mm	8mm - 56mm	13mm - 57mm

### CAD CROSS SECTION AND THERMAL PROFILE

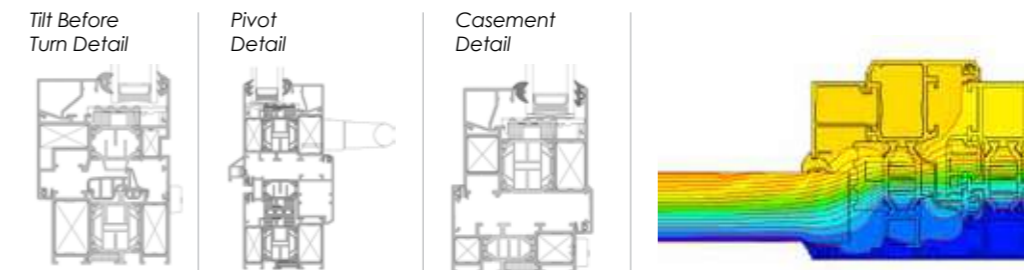

\* Window Energy Ratings and U-Values based on CEN size windows (1230mm x 1480mm) using 1.2 W/m²K double glazing with warm edge Swisspacer V bar. \*\* U-Values based on CEN size windows (1230mm x 1480mm) using 0.7 W/m²K triple glazing with warm edge Swisspacer V bar. Corresponds to the BRE Global Green Guide online generic specification for commercial windows and achieves a summary rating of B-E. [www.thegreenguide.org.uk](http://www.thegreenguide.org.uk) Element Number 831500018/831500006. Sound insulation values are Rw reduction values and are based on tests using acoustic glazing.

Please note: NBS Specifications are available for all products and BIM Components for many. Please visit [www.aluk.co.uk](http://www.aluk.co.uk) to download CAD files, BIM Components and NBS Specifications.



## 72BW/BD WINDOW AND DOOR SYSTEM

The 72BW/BD is a three chamber aluminium window and door system that offers high performance alongside a wide range of adaptable features, formats and configurations to meet the demands of your project.

### DESIGN FEATURES

- Three chamber high performance window and door system
- Windows available in three different styles (Soft Line/Flush/Picture Frame)
- Options available to increase thermal performance without changing profiles
- Both aluminium and PVC groove hardware available
- All certified under Secured by Design scheme

### OPTIONS

- Windows and doors can be manufactured to suit any configuration, style and design
- Full range of high quality hardware available
- Glazing sizes from 25mm - 65mm
- Wide range of security locking mechanisms to fully customise your window or door
- Available in single or dual colour option, polyester powder coating and anodised finishes

### WINDOW CONFIGURATIONS

- Single & Double Casement
- Side Hung & Bottom Hung (Open In)
- Tilt/Turn & Turn/Tilt
- Tilt & Slide
- Vertical & Horizontal Pivots
- Parallel opening vents
- Lifetime Homes (LTH)

### DOOR CONFIGURATIONS

- Single Doors (Open In)
- Single Doors (Open Out)
- Double Doors (Open In)
- Double Doors (Open Out)

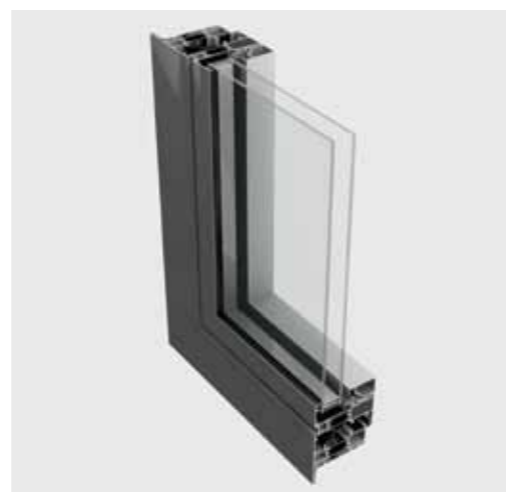

## 72BW/72BD WINDOW AND DOOR SYSTEM TECHNICAL SPECIFICATIONS

The 72BW/BD window and door system is available in a wide range of formats, configurations and styles to provide the perfect solution for your project. Combining high performance with stylish design, this fit for purpose window and door system is tried

and tested, exceeding many industry standards for safety and security. All systems have received 3rd party certification under the BSI Kitemark scheme. Anodised finishes are also available with marine grade guarantees on request.

SPECIFICATIONS	OUTWARD OPENING	INWARD OPENING	PIVOT	PARALLEL OPENING VENT	SINGLE & DOUBLE DOOR
<b>Performance &amp; Accreditation</b>					
U-Value (Double Glazing)*	1.7 W/m²K	1.7 W/m²K	1.8 W/m²K	1.7 W/m²K	1.7 W/m²K
U-Value (Triple Glazing)**	1.4 W/m²K	1.3 W/m²K	1.5 W/m²K	1.3 W/m²K	1.3 W/m²K
Window Energy Rating (WER)	npd	npd	npd	npd	npd
Green Guide Rating	B Rated	B Rated	B Rated	B Rated	B Rated
Acoustic Performance (dB)	Rw (C;Ctr) 40 (-2;-6) dB	Rw (C;Ctr) 40 (-2;-6) dB	npd	npd	Rw (C;Ctr) 35 (-2;-5) dB
Air Tightness (Pa)	Class 4	Class 4	Class 4	Class 4	Class 4
Water Tightness (Pa)	Class E2000	Class 7a	Class 6a	Class E1950	Class E750
Wind Load (Pa)	Class 4	Class 4	Class 4	Class E2400	Class 4
Security	EN 1627	EN 1627	EN 1627	npd	npd
Secured By Design	Yes	Yes	No	No	No
<b>Configurations</b>					
<b>Opening</b>	Open Out	Open In	Open Out	Open Out	Open In & Open Out
Top Hung	●	--	--	--	--
Side Hung	●	--	--	--	--
Bottom Hung	●	●	--	--	--
Fixed Light	●	●	●	●	●
Mullight	●	--	--	●	--
Tilt & Turn	--	●	--	--	--
Life Time Homes (LTH)	--	●	--	--	--
Tilt & Slide	--	●	--	--	--
Vertical Pivot	--	--	●	--	--
Horizontal Pivot	--	--	●	--	--
Parallel Opening Vent	--	--	--	●	--
<b>Size Limits</b>					
<b>Max Vent Weight</b>	--	--	--	--	100 Kg
Top Hung	90 Kg	--	--	--	--
Side Hung	130 Kg	--	--	--	--
Bottom Hung	90 Kg	100 Kg	--	--	--
Fixed Light	250 Kg	--	--	250 Kg	--
Tilt & Turn	--	130 Kg	--	--	--
Life Time Homes (LTH)	--	100 Kg	--	--	--
Tilt & Slide	--	100 Kg	--	--	--
Vertical Pivot	--	--	120 Kg	--	--
Horizontal Pivot	--	--	180 Kg	--	--
Parallel Opening Vent	--	--	--	200 Kg	--
<b>System Features</b>					
Frame Options	72mm	72mm	72mm	105mm	72mm
Dual Colour Option	●	●	●	●	●
Multi-Point Locking	●	●	●	●	●
Glazing Options	Internal	Internal	Internal	Internal	Internal
Glazing Thickness	13mm - 57mm	18mm - 66mm	13mm - 57mm	8mm - 56mm	13mm - 57mm

### CAD CROSS SECTION AND THERMAL PROFILE

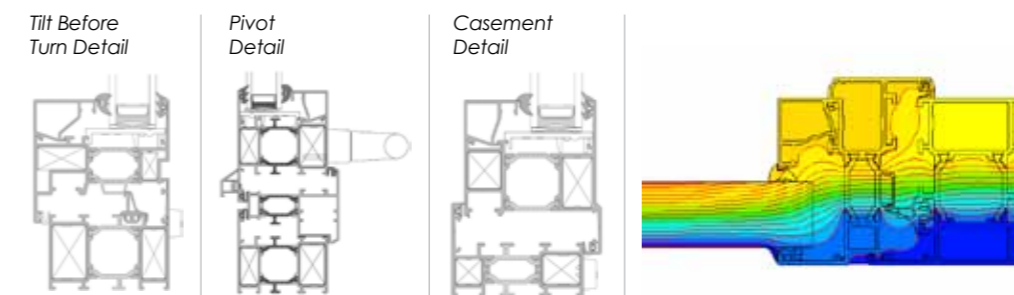

\* Window Energy Ratings and U-Values based on CEN size windows (1230mm x 1480mm) using 1.2 W/m²K double glazing with warm edge Swisspacer V bar. \*\* U-Values based on CEN size windows (1230mm x 1480mm) using 0.7 W/m²K triple glazing with warm edge Swisspacer V bar. Corresponds to the BRE Global Green Guide online generic specification for commercial windows and achieves a summary rating of B-E. [www.thegreenguide.org.uk](http://www.thegreenguide.org.uk) Element Number 831500018/831500006. Sound insulation values are Rw reduction values and are based on tests using acoustic glazing.

Please note: NBS Specifications are available for all products and BIM Components for many. Please visit [www.aluk.co.uk](http://www.aluk.co.uk) to download CAD files, BIM Components and NBS Specifications.



## 58BW/BD WINDOW AND DOOR SYSTEM

The 58BW/BD window and door system is the perfect choice for residential or commercial projects, offering a cost effective, high performance solution in a wide range of configurations and formats to suit your building design. The window system is available in Top Hung, Side Hung, Tilt before Turn, Fully Reversible and Steel Replacement formats with a range of glazing and hardware options. With clean lines and advanced functionality, this superior window and door system offers you the choice and flexibility to meet your needs.

### DESIGN FEATURES

- Windows available in internally or externally glazed options
- Flat, chamfered or Ovolo details to achieve traditional or contemporary appearances
- 58mm or 70mm frame depth to accommodate varying types of applications
- Project in or project out options, where applicable
- Integrated deep head profiles for ease of trickle ventilation
- Unique polyamide thermal break design to improve thermal performance
- Certified under Secured by Design scheme
- Door system with unique Polyamide Euro groove design
- Sculptured detail that creates a picture frame view through the door
- Accepts a full range of restrictors and access control devices
- Available as a standard door option or with PAS 23 / PAS24 upgrade
- Multi-point locking mechanisms for enhanced security
- Cloaking feature conceals lock and prevents any access to locking points

### OPTIONS

- Accommodates 24mm - 44mm glazing units for thermal and acoustic performance
- Double beaded option allow for internal glazing without the use of dummy vents
- Dedicated fixing straps for ease of installation
- Low threshold door option to comply with Part M – Building Regulation
- Full range of customisable hardware available
- Available in single or dual colour option, polyester powder coating and anodised finishes

### WINDOW CONFIGURATIONS

- Top Hung and Side Hung
- Side Hung & Bottom Hung (Open In)
- Tilt/Turn & Turn/Tilt
- Tilt & Slide
- Fully reversible
- Internally glazed beading options
- Project in or project out options
- Lifetime Homes (LTH)

### DOOR CONFIGURATIONS

- Single Doors (Open In)
- Single Doors (Open Out)
- Double Doors (Open In)
- Double Doors (Open Out)
- Lifetime Homes (LTH)



## 58BW/BD WINDOW AND DOOR SYSTEM TECHNICAL SPECIFICATIONS

The 58BW/BD window and door system has been designed to offer a high performance, narrow profile solution that has the range and flexibility to suit most projects. Windows are available in Top Hung, Side Hung, Tilt Before Turn and Fully-Reversible formats and a complete range of colours and finishes. Anodised finishes

are also available with marine grade guarantees on request. Certified under the Secured by Design scheme, and meeting all relevant standards, this competitively priced window and door system offers complete choice and flexibility.

SPECIFICATIONS	OUTWARD OPENING	INWARD OPENING	FULLY REVERSIBLE	SINGLE & DOUBLE DOOR
<b>Performance &amp; Accreditation</b>				
U-Value (Double Glazing)*	1.4 W/m <sup>2</sup> K	1.6 W/m <sup>2</sup> K	1.7 W/m <sup>2</sup> K	1.7 W/m <sup>2</sup> K
U-Value (Triple Glazing)**	1.2 W/m <sup>2</sup> K	1.2 W/m <sup>2</sup> K	--	1.4 W/m <sup>2</sup> K
Window Energy Rating (WER)	B - C	B - C	npd	npd
Green Guide Rating	A+ - A Rated	A+ - A Rated	B Rated	npd
Acoustic Performance (dB)	Rw (C;Ctr) 42 (-1;-5) dB	Rw (C;Ctr) 42 (-1;-5) dB	npd	npd
Air Tightness (Pa)	Class 4	Class 3	Class 4	Class 4
Water Tightness (Pa)	Class 9a	Class 9a	Class 6a	Class 7a
Wind Load (Pa)	Class E2400	Class E2400	Class 5	Class E2400
Security	Kitemarked to PAS 24	Kitemarked to PAS 24	Kitemarked to PAS 24	Kitemarked to PAS 24
Secured By Design	Yes	Yes	Yes	Yes
<b>Configurations</b>				
Opening	Open Out	Open In	Open Out	Open In & Open Out
Top Hung	●	--	--	--
Side Hung	●	--	--	--
Bottom Hung	●	--	--	--
Fixed Light	●	●	●	●
Multilight	●	--	--	--
Tilt & Turn	--	●	--	--
Life Time Homes (LTH)	--	●	--	--
Tilt & Slide	--	●	--	--
Top swing	--	--	●	--
Side Swing	--	--	●	--
<b>Size Limits</b>				
Max Vent Weight	--	--	--	90 Kg
Top Hung	90 Kg	--	--	--
Side Hung	55 Kg	--	--	--
Bottom Hung	60 Kg (3 Hinges)	100 Kg	--	--
Fixed Light	250 Kg	--	--	--
Tilt & Turn	--	100 Kg	--	--
Life Time Homes (LTH)	--	100 Kg	--	--
Tilt & Slide	--	100 Kg	--	--
Top swing	--	--	60 Kg	--
Side Swing	--	--	50 Kg	--
<b>System Features</b>				
Frame Options	58mm & 70mm	58mm & 70mm	70mm	58mm & 70mm
Dual Colour Option	●	●	●	●
Multi-Point Locking	●	●	●	●
Glazing Options	Internal & External	Internal	Internal	Internal
Glazing Thickness	24mm - 44mm	24mm - 44mm	28mm	24mm - 44mm

### CAD CROSS SECTIONS AND THERMAL PROFILE

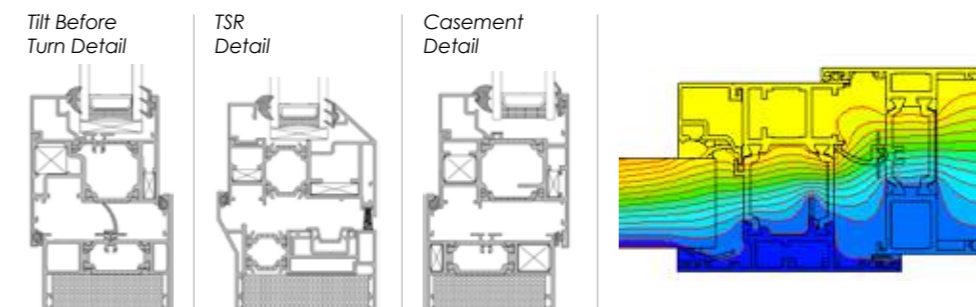

\* Window Energy Ratings and U-Values based on CEN size windows (1230mm x 1480mm) using 1.2 W/m<sup>2</sup>K double glazing with warm edge Swisspacer V bar. \*\* U-Values based on CEN size windows (1230mm x 1480mm) using 0.7 W/m<sup>2</sup>K triple glazing with warm edge Swisspacer V bar. Corresponds to the BRE Global Green Guide online generic specification for domestic windows and achieves a summary rating of B-C. [www.thegreenguide.org.uk](http://www.thegreenguide.org.uk) Element Number 813100001/813100007. \* Door U-Values based on CEN size ≤ 3600mm<sup>2</sup> using 1.2 W/m<sup>2</sup>K double glazing with warm edge Swisspacer V bar. \*\* U-Values based on CEN size ≤ 3600mm<sup>2</sup> using 0.7 W/m<sup>2</sup>K triple glazing with warm edge Swisspacer V bar. All weather test data taken from BS EN 6375-1 (Part of Pas 23) based upon highest performing door configuration. Sound insulation values are Rw reduction values and are based on tests using acoustic glazing.

Please note: NBS Specifications are available for all products and BIM Components for many. Please visit [www.aluk.co.uk](http://www.aluk.co.uk) to download CAD files, BIM Components and NBS Specifications.



## 58BW ST STEEL REPLACEMENT WINDOW SYSTEM

The 58BW ST window system provides an ideal solution for the replacement of existing steel windows. The system is available in a range of styles and can be top, bottom or side hung to meet the needs of your project. The design replicates the narrow sight lines associated with steel windows whilst providing superior performance and security.

### DESIGN FEATURES

- Slim sightlines to match existing steel windows
- Internally beaded for ease of site glazing on high-rise applications
- Unique polyamide thermal break design to improve performance
- Integrated deep head profiles for ease of trickle ventilation
- Accommodates standard hardware including friction stays and shoot bolt locking
- Certified under the Secured by Design scheme

### OPTIONS

- Accommodates 24mm - 28mm glazing units for thermal and acoustic performance
- Double beaded option allows internal glazing without the use of dummy vents
- Dedicated fixing straps for ease of installation
- Full range of customisable hardware available
- Available in single or dual colour option, polyester powder coating and anodised finishes

### CONFIGURATIONS

- Top, Bottom or Side Hung
- Outward Opening
- Fixed Lights



## 58BW ST STEEL REPLACEMENT WINDOW SYSTEM TECHNICAL SPECIFICATIONS

Designed to replace and complement existing steel windows, the 58BW ST window range has been developed to retro fit mansion blocks, warehouses and similar buildings where steel windows have been traditionally fitted. They are available in a wide

range of standard colours as well as any RAL colour and include hardware that is sympathetic to the traditional steel window designs. Anodised finishes are also available with marine grade guarantees on request.

SPECIFICATIONS	
<b>Performance &amp; Accreditation</b>	
U-Value (Double Glazing)*	1.4W/m²K
Uf-Value (Triple Glazing)**	--
Window Energy Rating (WER)	A - B
Green Guide Rating	A+ - A Rated
Acoustic Performance (dB)	npd
Air Tightness (Pa)	Class 4
Water Tightness (Pa)	Class 9a
Wind Load (Pa)	Class E2400
Security	Kitemarked to PAS 24
Secured By Design	Yes
<b>Configurations</b>	
Opening	Open Out
Top Hung	●
Side Hung	●
Bottom Hung	●
Fixed Light	●
Multilight	●
Tilt & Turn	--
Life Time Homes (LTH)	--
Tilt & Slide	--
Top swing	--
Side Swing	--
<b>Size Limits</b>	
Max Vent Weight	--
Top Hung	50 Kg
Side Hung	24 Kg
Bottom Hung	60 Kg (3 Hinges)
Fixed Light	250 Kg
Tilt & Turn	--
Life Time Homes (LTH)	--
Tilt & Slide	--
Top swing	--
Side Swing	--
<b>System Features</b>	
Frame Options	58mm
Dual Colour Option	●
Multi-Point Locking	●
Glazing Options	Internal
Glazing Thickness	24mm - 28mm



Flat Line Vent



Steel Look Putty Line Vent



Steel Look Stepped Edge Vent

### CAD CROSS SECTIONS AND THERMAL PROFILE

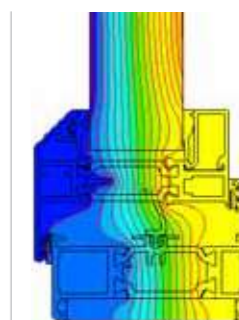
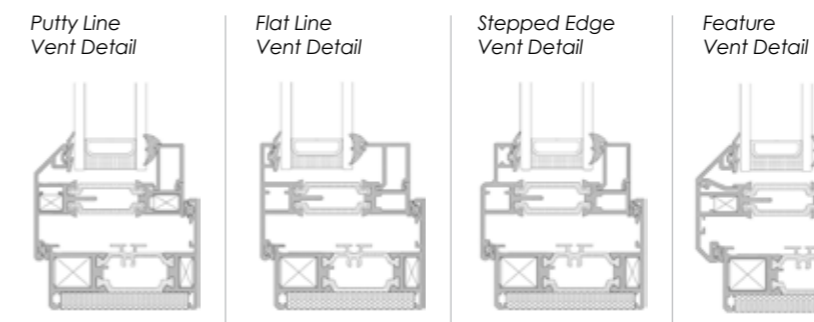

\* Window Energy Ratings and U-Values based on CEN size windows (1230mm x 1480mm) using 1.2 W/m²K double glazing with warm edge Swisspacer V bar. Corresponds to the BRE Global Green Guide online generic specification for domestic windows and achieves a summary rating of B-C. [www.thegreenguide.org.uk](http://www.thegreenguide.org.uk) Element Number 813100001/813100007. Sound insulation values are Rw reduction values and are based on tests using acoustic glazing. Corresponds to the BRE Global Green Guide online generic specification for commercial windows and achieves a summary rating of A+/A-. [www.thegreenguide.org.uk](http://www.thegreenguide.org.uk) Element Number 831500018/831500006. Sound insulation values are Rw reduction values and are based on tests using acoustic glazing.

Please note: NBS Specifications are available for all products and BIM Components for many. Please visit [www.aluk.co.uk](http://www.aluk.co.uk) to download CAD files, BIM Components and NBS Specifications.



## GT55 TB THERMALLY BROKEN COMMERCIAL DOOR SYSTEM

The GT55 TB commercial door system provides the ultimate combination of security and performance. It also includes thermal break profiles for improved performance. It is ideal for a range of heavy duty commercial and public sector applications including offices, hospitals, schools, warehousing and other industrial applications.

### DESIGN FEATURES

- Anti-finger trap styles
- Thermal break technology for enhanced thermal performance
- Unique security and safety features
- DDA compliant overhead closer options using Dorma RTS 87
- Structurally enhanced door framing
- Fully glazed, commercial swing door
- Incorporates high security mechanical dead lock
- Mechanical and electro-mechanical multi-point locking options
- Dual colour

### OPTIONS

- Available with a full range of security and customisable hardware
- Electronic and manual access systems easily integrated
- Glazed or non-glazed options
- Available in single or dual colour option, polyester powder coating and anodised finishes
- Standard or DDA compliant overhead closer

### CONFIGURATIONS

- Single Doors (Open In)
- Single Doors (Open Out)
- Double Doors (Open In)
- Double Doors (Open Out)



## GT55 TB THERMALLY BROKEN COMMERCIAL DOOR SYSTEM TECHNICAL SPECIFICATIONS

GT55 TB is one of the most robust thermally broken commercial door systems available on the market. The system has been fully tested and can be integrated with our GT55 ground floor treatment system. This robust and low maintenance door provides complete

flexibility in entrance solutions and is available in a wide range of colours and finishes to suit any project.

SPECIFICATIONS	SINGLE & DOUBLE THERMALLY BROKEN DOOR
<b>Performance &amp; Accreditation</b>	
U-Value (Double Glazing)*	2.0 W/m <sup>2</sup> K
U-Value (Triple Glazing)**	-
Green Guide Rating	C Rated
Acoustic Performance (dB)	npd
Air Tightness (Pa)	npd
Water Tightness (Pa)	npd
Wind Load (Pa)	npd
Security	npd
<b>Configurations</b>	
Opening	Open Out & Open In
Top Hung	--
Side Hung	--
Fixed Light	--
Tilt & Turn	--
Single Door	•
Double Door	•
Sliding Door	•
<b>Design Features</b>	
Max Vent Weight	80 Kg
Top Hung	--
Side Hung	--
Fixed Light	--
Tilt & Turn	--
<b>Size Limits</b>	
Frame Options	110mm
Dual Colour Option	--
Single Point Locking	•
Multi-Point Locking	•
Electro Mechanical Locking	•
Glazing Options	Internal
Glazing Thickness	24mm - 40mm



Thermally broken door system

## CAD CROSS SECTIONS AND THERMAL PROFILE

Threshold Detail

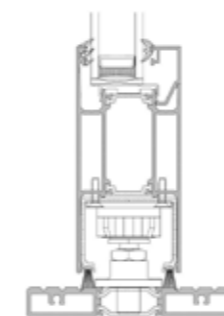

Transom Detail

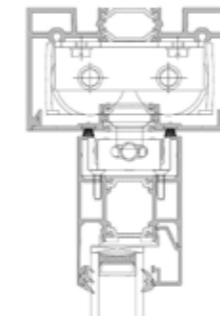

Lock Stile Detail

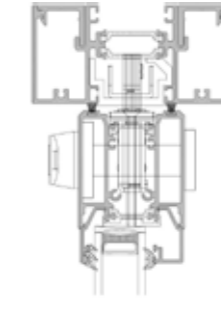

AFT Hinge Stile Detail

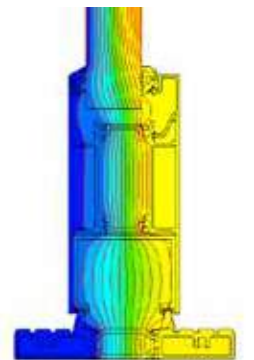
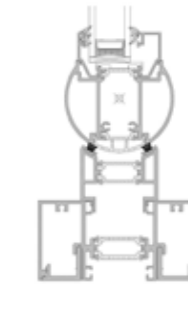

U-Values based on 14351 size door (1000mm x 2180mm) using 1.1 W/m<sup>2</sup>K double glazing with warm edge Swisspacer V bar. \*\* U-Values based on 14351 size door (2000mm x 2180mm) using 0.7 W/m<sup>2</sup>K triple glazing with warm edge Swisspacer V bar. All weather test data taken from BS EN 6375-1 (Part of Pas 23) based upon highest performing door configuration. Sound insulation values are Rw reduction values and are based on tests using acoustic glazing.

Please note: NBS Specifications are available for all products and BIM Components for many. Please visit [www.aluk.co.uk](http://www.aluk.co.uk) to download CAD files, BIM Components and NBS Specifications.



## GT55 NI NON-INSULATED DOOR SYSTEM

The GT55 NI commercial door system provides the ultimate in security, certified to LPS 1175 (SR2) and by Secured by Design at a competitive price point. It does not include insulation and thus is ideal for a range of high traffic applications in the commercial and public sector including retail outlets, offices, hospitals, schools, warehousing as well as other industrial applications. This system is also available as a traditional commercial doorset.

### DESIGN FEATURES

- Unique security and safety features
- Ultra secure, specialist glazing
- Structurally enhanced door framing
- Fully glazed, commercial swing door
- Incorporates the Adams Rite Sentinel 6 mechanical dead lock
- Integrated with GT55 ground floor treatment system

### OPTIONS

- Available with a full range of security and customisable hardware
- Electronic and manual access systems easily integrated
- Glazed or non-glazed options
- Available in single or dual colour option, polyester powder coating and anodised finishes
- SBD LP51175 & PAS 24 compliant

### CONFIGURATIONS

- Single Doors (Open In)
- Single Doors (Open Out)
- Double Doors (Open In)
- Double Doors (Open Out)

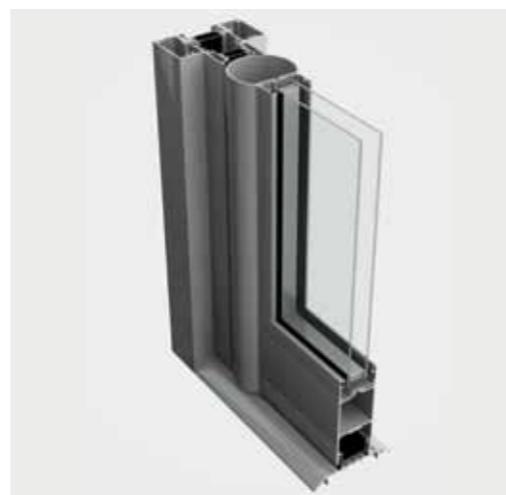

## GT55 NI NON-INSULATED DOOR SYSTEM TECHNICAL SPECIFICATIONS

Available in standard, PAS 24 and LPS1175 (SR2) options, the GT55 NI aluminium door system is one of the most secure swing doors available on the market. The system has been fully tested with full glazing, no use of steel reinforced panels, as well as

with semi-glazing and can be integrated with our ground floor treatment systems. It suited to high traffic environments where no insulation is required.

SPECIFICATIONS	SINGLE & DOUBLE NON-INSULATED DOOR
<b>Performance &amp; Accreditation</b>	
U-Value (Double Glazing)*	3.1 W/m²K
U-Value (Triple Glazing)**	--
Green Guide Rating	C Rated
Acoustic Performance (dB)	npd
Air Tightness (Pa)	npd
Water Tightness (Pa)	npd
Wind Load (Pa)	npd
Security	LPS1175 SR2 / PAS 24
<b>Configurations</b>	
Opening	Open Out & Open In
Top Hung	--
Side Hung	--
Fixed Light	--
Tilt & Turn	--
Single Door	•
Double Door	•
Sliding Door	•
<b>Design Features</b>	
Max Vent Weight	80 Kg
Top Hung	--
Side Hung	--
Fixed Light	--
Tilt & Turn	--
<b>Size Limits</b>	
Frame Options	110mm
Dual Colour Option	--
Single Point Locking	•
Multi-Point Locking	--
Electro Mechanical Locking	•
Glazing Options	Internal
Glazing Thickness	24mm - 28mm



Non-insulated door system

## CAD CROSS SECTION AND THERMAL PROFILE

Transom Detail

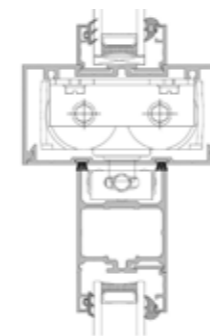

Lock Stile Detail

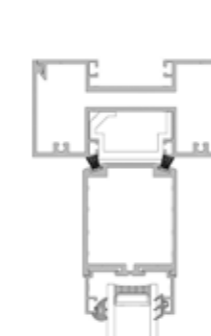

Threshold Detail

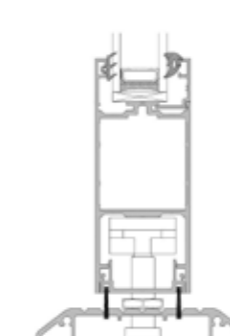

AFT Hinge Stile Detail

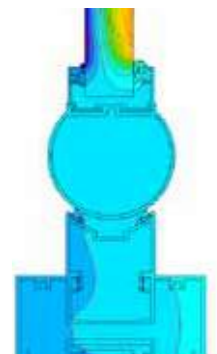
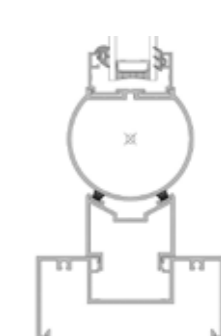

U-Values based on 14351 size door (1000mm x 2180mm) using 1.1 W/m²K double glazing with warm edge Swisspacer V bar. All weather test data taken from BS EN 6375-1 (Part of Pas 23) based upon highest performing door configuration. Sound insulation values are Rw reduction values and are based on tests using acoustic glazing.

Please note: NBS Specifications are available for all products and BIM Components for many. Please visit [www.aluk.co.uk](http://www.aluk.co.uk) to download CAD files, BIM Components and NBS Specifications.