

DETAIL 1/414

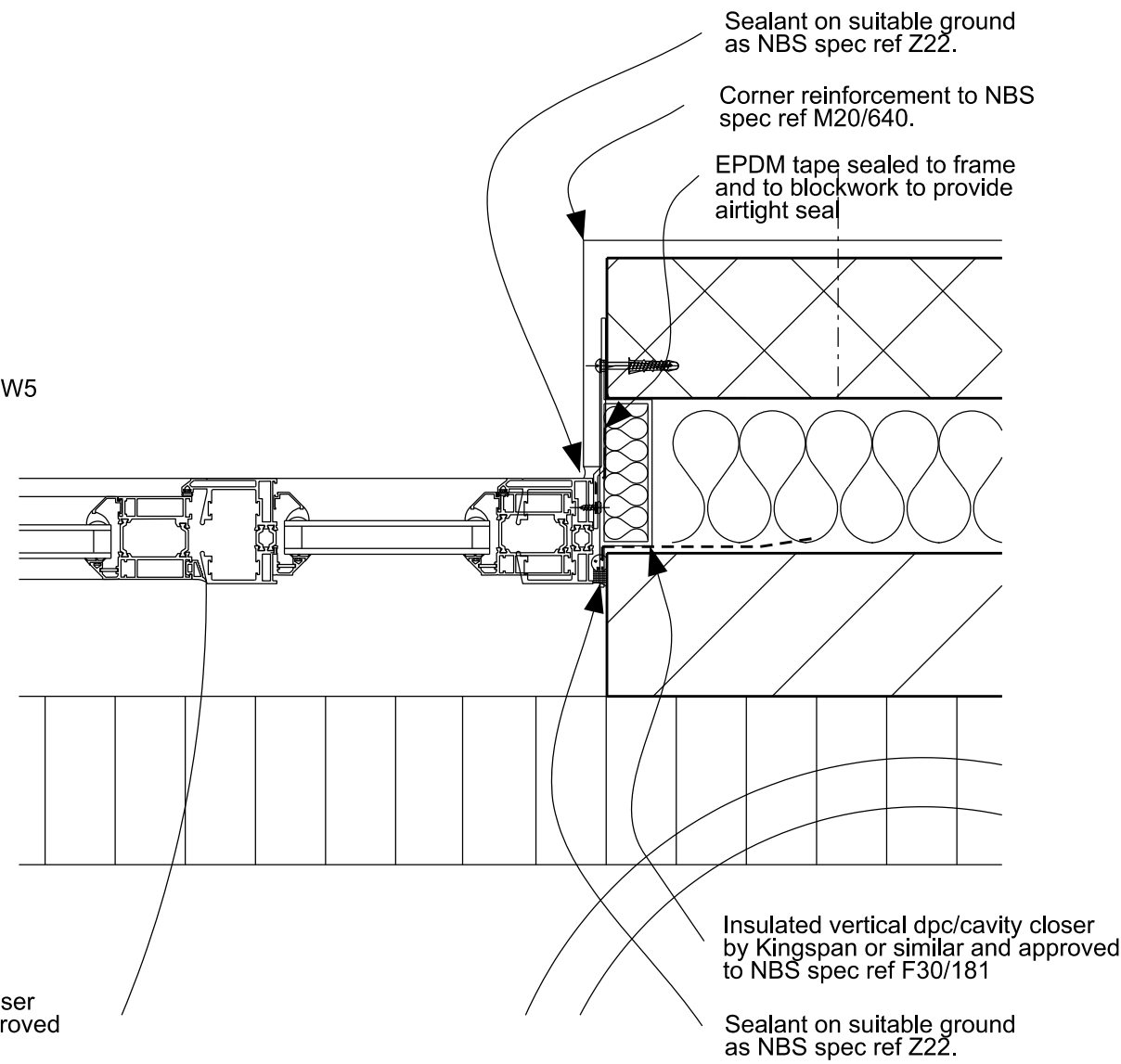

DETAIL 2/414

CONSTRUCTION ISSUE

PROJECT  
BUNGALOW AT BROOKFIELD HOUSE  
FOR MR C FREEMAN

DWG NO  
BBH.17.414A

SCALE  
1:5 @ A3

DATE  
SEP 2017

REVISED  
A 29.06.18 Cavity closer details revised



ARCHITECTS  
INTERIOR  
+ URBAN  
DESIGNERS  
DAVID RICHMOND  
AND PARTNERS LTD

The Studio  
1 Southwood  
Lawn Road  
London N6 5SD  
T 07803 084 788  
E david@dr-p.co.uk

THIS DRAWING  
IS COPYRIGHT  
ALL DIMENSIONS TO  
BE CHECKED ON SITE  
DO NOT SCALE