

DETAIL 1/411

100mm full fill cavity insulation NBS F30/150 in 110mm cavity with s.s. cavity ties at 450ctrs.
 Brickwork to NBS F10/110 with black mortar to NBS Z21

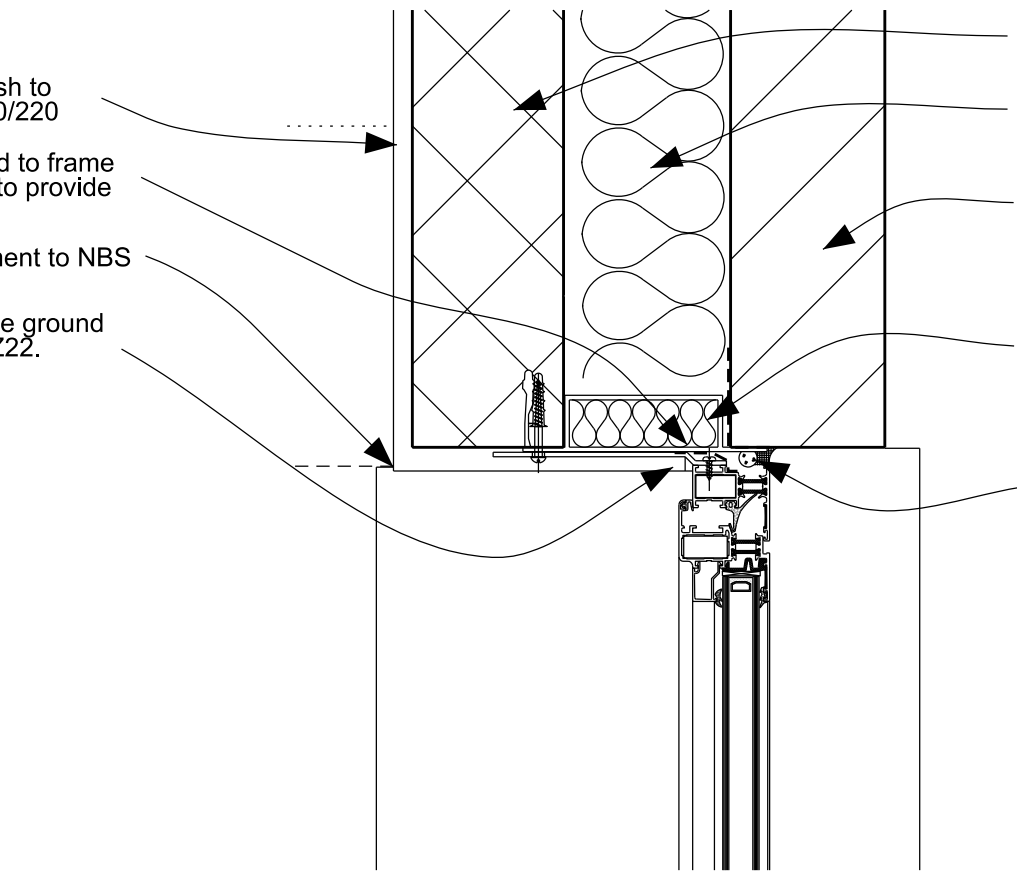

DETAIL 3/411

100mm Tarmac Toplite GTI concrete blockwork NBS F10/355
 100mm full fill cavity insulation NBS F30/150 in 110mm cavity with s.s. cavity ties at 450ctrs.
 Brickwork to NBS F10/110 with black mortar to NBS Z21
 Insulated vertical dpc/cavity closer by Kingspan or similar and approved to NBS spec ref : F30/181
 Sealant on suitable ground as NBS spec ref Z22.

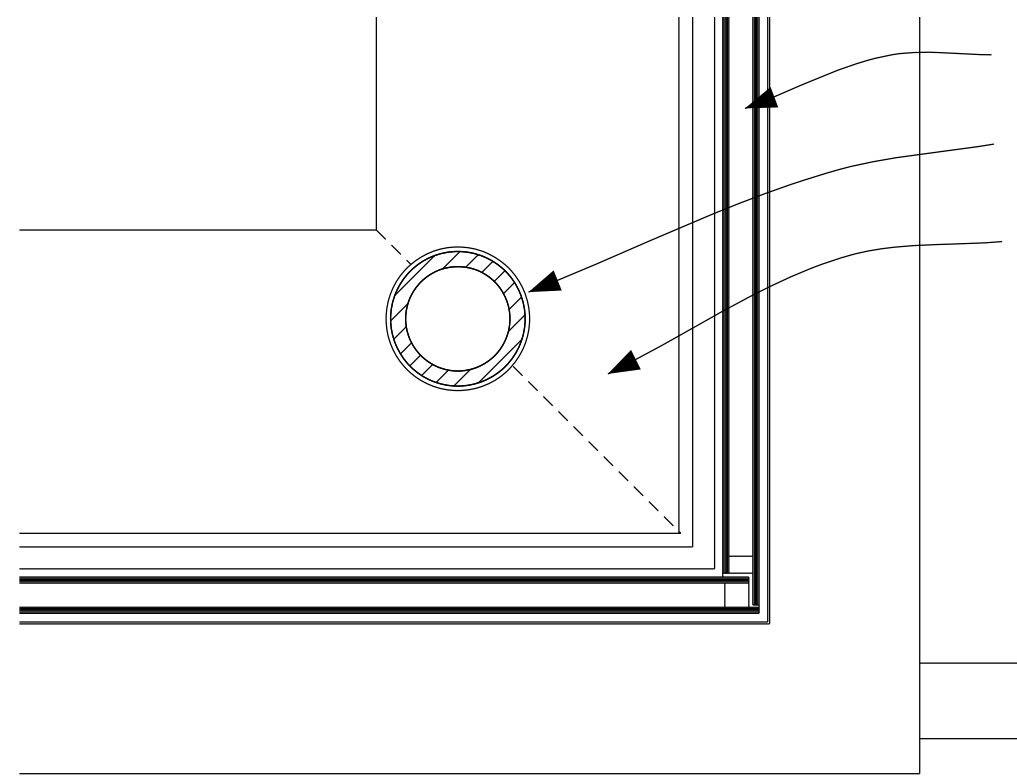

DETAIL 2/411

For detail of corner window W2 refer to drg BBH.17.501.
 Painted steel CHS to Structural Engineers spec
 Painted WBP grade MDF window cill board neatly cut around CHS post with 3mm gap filled with flexible sealant to match paint colour.

PROJECT
 BUNGALOW AT BROOKFIELD HOUSE
 FOR MR C FREEMAN

DWG NO
 BBH.17.411A

SCALE
 1:5 @ A3

DATE
 SEP 2017



ARCHITECTS
 INTERIOR
 + URBAN
 DESIGNERS
 DAVID RICHMOND
 AND PARTNERS LTD

The Studio
 1 Southwood
 Lawn Road
 London N6 5SD
 T 07803 084 788
 E david@dr-p.co.uk

THIS DRAWING
 IS COPYRIGHT
 ALL DIMENSIONS TO
 BE CHECKED ON SITE
 DO NOT SCALE

REVISIONS
 A 29.06.18 Cavity closer detail revised

TITLE
 PLAN DETAILS OF KITCHEN WINDOW W2

CONSTRUCTION ISSUE