



Architectural Specification Manual

CONTENTS

SECTION		PAGE
1	INTRODUCTION	
1.1	Background	1
1.2	Westcrowns Contracting Services Ltd.	1
1.3	Glossary of Terms	2
2	PRODUCT DESCRIPTION	
2.1	Components	3
2.2	Glass Types and Sizes	5
2.3	Standard Glass Types	6
2.4	Available Glass Types	7
2.5	Physical Properties	8
2.6	Performance Tables	9
2.7	Testing	10
2.8	Glass Finishes	11
3	SCHEDULE OF COMPONENTS	
3.1	Normal Profile Glass Profiles	12
3.2	Normal Profile Aluminium Frames	13
3.3	Normal Profile Thermal Break Aluminium Frames	14
3.4	Special Profile Glass Profiles	15
3.5	Special Profile Aluminium Frames	16
3.6	Special Profile Thermal Break Aluminium Frames	17
3.7	Plastic Insert	19
4	INSTALLATION DESIGN OPTIONS	
4.1	Installation Options	20
4.2	Admissible Span Design Charts	23
5	INSTALLATION DETAILS	
5.1	Normal Profile Head and Base Details – For Internal Glazing	24
5.2	Normal Profile Jamb Detail – For Internal Glazing	25
5.3	Normal Profile Head and Base Details – For External Glazing	26
5.4	Normal Profile Jamb Detail – For External Glazing	27
5.5	Special Profile Head and Base Details – For External Glazing	28
5.6	Special Profile Jamb Detail – For External Glazing	29
5.7	Special Profile Horizontal Base Detail – For External Glazing	30
5.8	Special Profile Horizontal Head Detail – For External Glazing	31
5.9	Special Profile Horizontal Jamb Detail – For External Glazing	32
6	SPECIFICATIONS	
6.1	For Use in Internal Partitions	33
6.2	For Use in External Screens	34
7	BIBLIOGRAPHY	35

Profilit™ is a trademark of Pilkington.as

The data quoted within this publication is relevant only to the performance of the Pilkington Profilit™ glass system.

The manufacturer reserves the right to change or discontinue any specification or products without notification. All goods are subject to availability.

This publication gives a general description of the product and materials and should be used as a guide only. It is the responsibility of the user of this document to ensure that the use of Pilkington Profilit™ system is appropriate for any particular application, and that such applications comply with all the relevant local and national legislation, standards, codes of practice and other requirements. Reglit Glass Architecture hereby disclaim all liability, howsoever arising, from any error in or omission from this publication and the consequences of relying upon it.

SECTION 1 - INTRODUCTION

1.1 Background

The Pilkington **Profilit™** Glass has been produced in Germany for over 35 years and is accepted as a standard building component for large-scale construction projects. The glass channel is a cast glass formed through computer-controlled furnaces, consistently producing glass of the highest quality and to accurate dimensions.

The U-shape configuration of the glass produces a high structural strength within the channel, allowing it to be installed at high level or in large units without the need for additional horizontal or vertical supports. The system offers outstanding performance giving high levels of light permeability, exceptional sound and heat insulation.

Pilkington, who are the world leader in profiled glass manufacture, have centralized their production within **Pilkington Bauglasindustrie**, one of their main facilities in Germany. This company now produces the full range of products for the profiled glass system and currently the annual production is approximately 1 million m² of glass each year.

The two production types of profiled glass – the Reglit® and **Profilit™** Glass systems – amalgamated in 1996 within **Pilkington Bauglasindustrie**. This restructuring resulted in the use, throughout Europe, of the two brand names - Reglit® and **Profilit™**. Within the UK the brand name used for the last 10 years has been Reglit®, however, in line with **Pilkington's** recent rationalization of all of the company's products under single brand names the **Profilit™** name has replaced the previous brand name of Reglit®.

1.2 Reglit/Westcrowns Contracting Services Ltd.

Reglit Glass Architecture, a division of the independent Westcrowns Contracting Services Ltd, are the exclusive distributors of the Pilkington **Profilit™** glazing system in the United Kingdom and Ireland. The Westcrowns Group was established in 1873 and has over 135 years experience within the glazing industry. Reglit, the Westcrowns Group and Pilkington enjoy a unique and successful relationship, which stretches over 125 years.

With over 14 years experience in the design and specification of the Pilkington **Profilit™** System, the Reglit team are acknowledged as the experts in their field. With qualified engineers, off-site and on-site testing experience and CAD facilities, we offer the project team unique design expertise and advice on a variety of technical issues.

From design to completion of the works, we strive to exceed the levels of professionalism expected from our company, allowing the designer the Freedom to Design in Glass.

SECTION 1 - INTRODUCTION

1.3 Glossary of terms

- Plank – A length of Pilkington **Profilit™**.
- Vertical Assembly – A Pilkington **Profilit™** glazing system where the individual planks are installed at 90° to the horizontal. (See Figure 1)
- Horizontal Assembly – A Pilkington **Profilit™** glazing system where the individual planks are installed horizontally. (See Figure 2)
- Vertical Glazing – Glazing installed at true vertical or 10° degrees either side of true vertical.
- Sloping Glazing – Glazing installed between horizontal and 75° from horizontal.

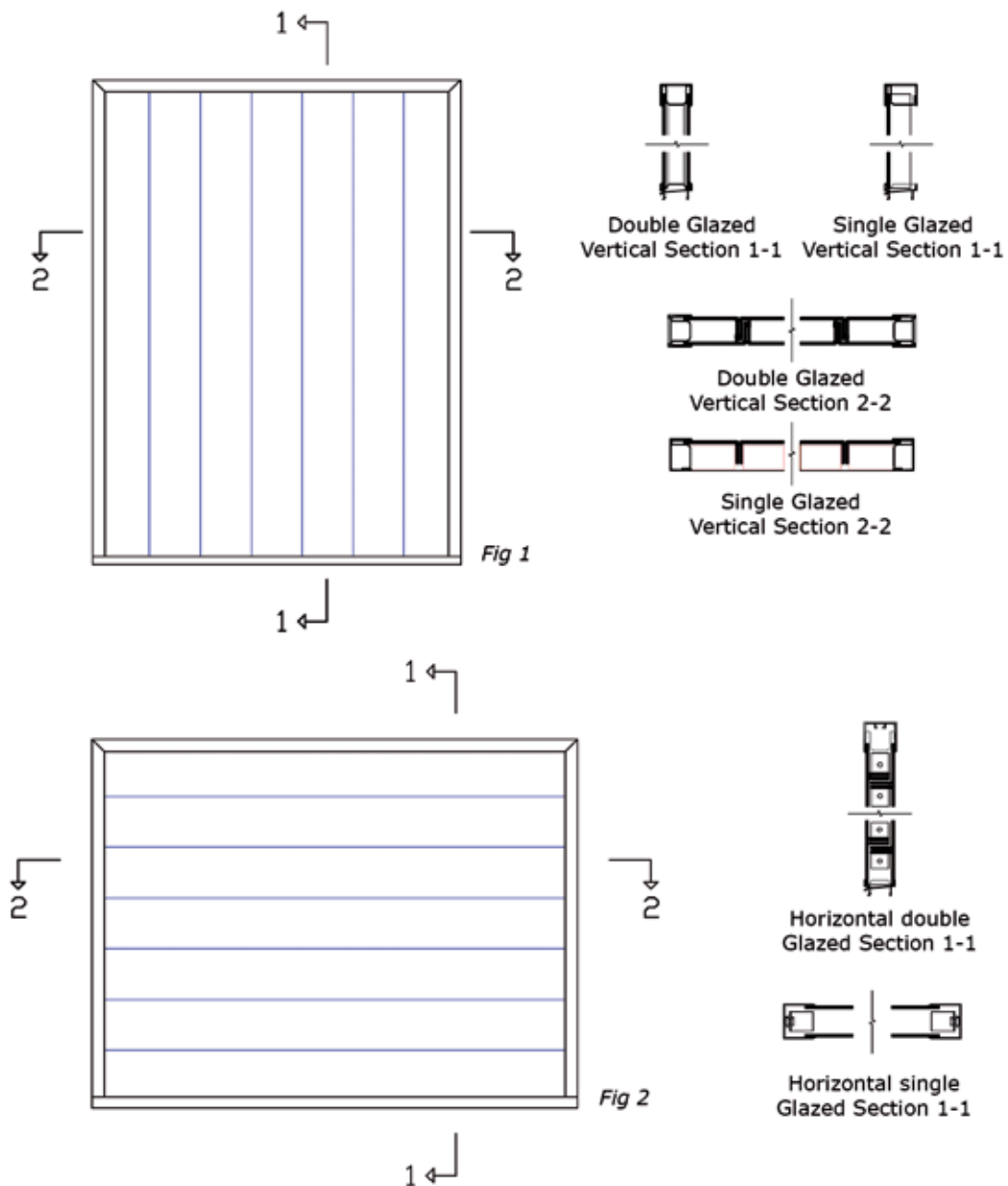

Section 2 - PRODUCT DESCRIPTION

2.1 Components - The Pilkington Profilit™ System

This simple concept of self-supporting glass channels within an extruded aluminium perimeter frame enables the creation of many innovative and exciting architectural designs. With few components and a practical design process, the Pilkington Profilit™ system combines versatility with exceptional performance to produce an outstanding glazing product.

Glass

Two main ranges of the glass are available - the Normal Profile (NP) system for standard glazing applications and the Special Profile (SP) system where the installation must withstand high lateral loads. By varying the profile in width, flange depth and thickness, the correct profile can be found for most installation. All glass types are available with or without stainless steel, longitudinal wires, providing a level of safety and security properties appropriate for the application.

All coated or uncoated Pilkington Profilit™ glass is manufactured to comply with EN 572-7. The product supplied is **CE** marked in accordance with EN 572-9.

Pilkington Profilit™ Standard	Standard glass channels formed with a cast outer surface, which diffuses incoming light, creating a slight green colouring to the glass.
Pilkington Profilit™ Amethyst	Amethyst coloured coated glass with a cast outer surface.
Pilkington Profilit™ Clear	Non-coloured glass with no ornamentation to the outer surface, providing greater transparency.
Pilkington Profilit™ Clear Amethyst	Blue coated glass with no ornamentation to the outer surface.
Pilkington Profilit™ Plus	Low emissivity glass type, producing efficient U-values with a cast outer surface.
Pilkington Profilit™ Clear Plus	Low emissivity glass type, producing efficient U-values with no ornamentation to the outer surface.
Pilkington Profilit™ Antisol	Bronze coated, solar coated glass, reducing heat transmission.



Section 2 - PRODUCT DESCRIPTION

2.1 Components - The Pilkington Profilit™ System (continued)

Aluminium

The aluminium perimeter framework consists of a simple periphery channel system incorporating a locating plastic insert for the glass. The complete aluminium profile range is extruded from high-grade aluminium, which allows for easy curving of the system. The frames can also be anodised or powder coated in a full range of architectural colours.

The profiles are available in two main ranges to fit both the NP and SP glass types, with a large variety of extrusions to suit any installation condition. Profiles that incorporate a thermal break to prevent cold bridging through the glazing system are also available. The impact and weather resistant plastic retaining insert locates the glass within the aluminium frame thus preventing glass to metal contact. The simplicity of the aluminium framework, with the small number of components, allows for a quick and easy installation process.

Silicone

The silicone sealant used is a high quality translucent silicone, which picks up the natural tint of the glass. The sealant is applied to all joints, i.e. glass to glass, glass to aluminium and aluminium to structure, providing a completely weather tight seal to the system. The silicone recommended is a one-part moisture curing sealant. The sealant has outstanding durability, resisting chemical and atmospheric deterioration.

Impact Gasket

The impact gasket is used to enhance the acoustic and safety properties of the glass in the system. To improve the acoustical properties to a maximum, gaskets #165 and #166 should be used.

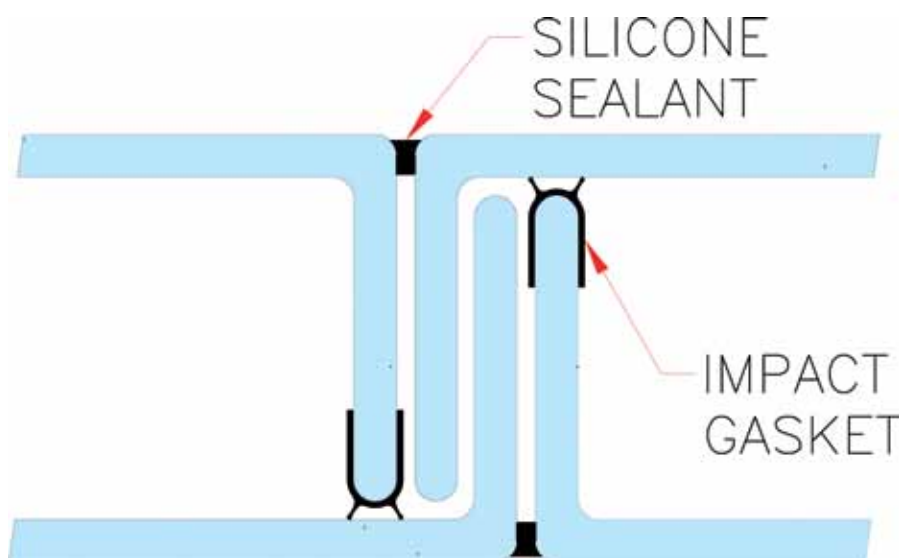

For glass sizes please see diagram on page 6

Section 2 - PRODUCT DESCRIPTION

2.2 Glass Types and Sizes

To identify the most suitable glass type for a particular application, the following criteria must be taken into account: -

- Structural and wind loading requirements
- Performance requirements
- Aesthetic considerations

Structural and wind loading requirements

Two main ranges of Pilkington **Profilit™** glass are available - Normal Profile (NP) for standard glazing applications and Special Profile (SP) where the system must either withstand high lateral loads or be installed in large spans. Please refer to the Installation Design Options section for the wind load and admissible span tables.



Performance requirements

The Requirements of Part L (England and Wales) and Part J (Scotland) of the Building Regulations can be complied with by using Pilkington **Profilit™** Plus that uses a hard, low-e pyrolytic surface coating applied to the internal surface of the glass channel. This provides improved thermal insulation properties giving a U-value of 1.8W/m²K that will meet the 2.2W/m²K requirement of the Building Regulations.

The Requirements of Building Regulations relating to human impact safety, e.g. Part N (England and Wales) and Part P (Scotland), can be met by using Pilkington **Profilit™** that incorporates longitudinal, stainless steel wires within the body of the glass channels. The use of the wire-line product together with the impact gaskets ensures that the risk of injury is reduced.

For performance tables please see page 9

Section 2 - PRODUCT DESCRIPTION

Aesthetic considerations

Surface coating - Specific metal oxide coatings may be applied to the internal surface of the glass channels to provide decorative or coloured finishes i.e. Pilkington **Profilit™** Amethyst.

Sandblasting - To provide a more translucent finish to all non-coated standard glass types. All standard glass types are available with a sandblasted finish to the internal surface of the glass channel. This will give a more opaque finish and we recommend using sandblasted where you require light transmission but do not want to see through the glass.

Painting - For a more bespoke range of colours, it is possible to apply a 'wash coat' of translucent enamel paint to the sandblasted surface. This procedure creates a coloured tint to the glass but still allows for light transmission through the glass channels. *We have previously used this technique to create coloured walls of glass and specific logos and designs.*

Filming – Adhesive backed polymeric films can be applied to the inner surface of the channel glass. The films can offer solar control performance, improved u-value, as well as safety and security.

2.3 Standard Pilkington Profilit™ Glass types

The standard Pilkington **Profilit™** glass types have a roughcast pattern to the outer surface of the glass channel. This pattern diffuses incoming light, creating a slight green tint to the glass.

STANDARD GLASS TYPES	Normal Profile		Special Profile		
	NP26	NP3*	SP2	SP26	SP3*
Width (w) mm	262	331	232	262	331
Flange height (h) mm	41	41	60	60	60
Glass thickness (t) mm	6	6	7	7	7
Weight kg/m ² .	19	18.2	25.5	24.5	22.5
Number of longitudinal wires at 25mm centres	8	10	7	8	10
Number of longitudinal wires at 15mm centres	16			16	
Maximum Lengths in metres	7	7	7	7	7

* Please contact our technical department regarding the feasibility of using these glasses on particular projects via freedom@reglit.com.

Tolerances

w	+/- 2.0mm
h	+/- 1.0mm
t	+/- 0.2mm

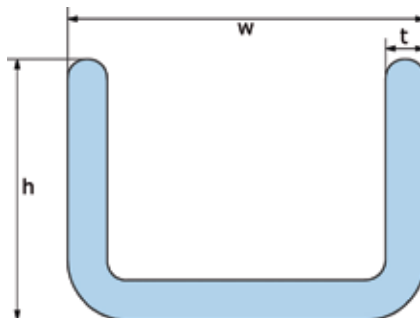

The glass is available in a variety of different stock lengths - from 2 metres to 7 metres, in 0.5 metre increments. The height of the glazing is dependent upon the type of installation, i.e. whether horizontal or vertical, internal or external, and the anticipated wind loading. A guide to the admissible heights is contained within the Installation Design Options section.

Section 2 - PRODUCT DESCRIPTION

2.4 Available Pilkington Profilit™ Glass Types

GLASS TYPES	NORMAL PROFILE		SPECIAL PROFILE		
	NP26	NP3	SP2	SP26	SP3
Profilit™ Standard Wired	Y	Y	Y	Y	Y
Profilit™ Standard Non-wired	Y	Y	Y	Y	Y
Profilit™ Amethyst (blue) Wired	Y	N	N	Y	N
Profilit™ Amethyst (blue) Non-wired	Y	S	N	Y	N
Profilit™ Clear (no surface ornamentation) Wired	S	N	N	S	N
Profilit™ Clear (no surface ornamentation) Non-wired	S	N	N	S	N
Profilit™ Clear Amethyst (no surface ornamentation) Wired	S	N	N	S	N
Profilit™ Clear Amethyst (no surface ornamentation) Non-wired	S	N	N	S	N
Profilit™ Plus (thermal insulating) Wired	Y	S	Y	Y	S
Profilit™ Plus (thermal insulating) Non-wired	Y	S	Y	Y	S
Profilit™ Clear Plus (thermal insulating) Wired	S	N	N	S	N
Profilit™ Clear Plus (thermal insulating) Non-wired	S	N	N	S	N
Profilit™ Antisol (solar control) Wired	S	S	S	S	N
Profilit™ Antisol (solar control) Non-wired	S	S	S	S	N
Profilit™ Standard Wired Low Iron	S	S	S	S	S
Profilit™ Standard Non-wired Low Iron	S	S	S	S	S
Profilit™ Clear Wired Low Iron	S	S	S	S	S
Profilit™ Clear Non-wired Low Iron	S	S	S	S	S
Profilit™ Wave	Y	N	N	Y	N
Profilit™ Macro	Y	N	S	Y	N
Profilit™ Slimline	Y	N	S	Y	N

KEY Y Standard Production
 S Special Production
 N Currently Unavailable

For further information and to check availability of these glass types please contact our technical department.

Section 2 - PRODUCT DESCRIPTION

2.5 Physical Properties

Optical

As natural light is an essential factor in the internal environment of a building, the incorporation of the Pilkington **Profilit**[™] system is therefore ideal to transmit the maximum amount of daylight, without compromising the thermal or weathering performance of the external skin. The light transmission levels of uncoated Pilkington **Profilit**[™] glass are between 86% and 75% depending on whether the system is single or double-glazed. The use of coated versions would reduce the light transmission.

The absence of any intermediate horizontal and vertical framing sections ensures that the Pilkington **Profilit**[™] system will always provide the maximum light transmitting surface area for any glazed opening, with the cast surface of the glass allowing the light through to the designated area.

For increased vision through the system, glass type Pilkington **Profilit**[™] Clear can be incorporated. This specially produced, smooth surfaced glass can provide a higher level of vision, whilst not quite producing the same level of transparency as float glass.

Acoustic

Noise is recognised as a serious health hazard within the working environment. The Pilkington **Profilit**[™] system using SP double glazing with gaskets #165 and #166 can provide a sound insulation level of up to 41 dB, which compares favourably with any high specification glazing system.

Thermal Insulation

With over 95% of the Pilkington **Profilit**[™] system consisting of glass, the issue of excessive heat loss through the glazed areas must be addressed. A system has therefore been developed by the manufacturers - Pilkington - to provide a high level of thermal insulation. The normal profile system (NP), when double glazed, will provide a U-value of 2.8 W / m²K with the special profile system (SP) providing a U-value of 2.7 W / m²K. By introducing one layer of the specially coated glass type Pilkington **Profilit**[™] Plus into the double glazing and using thermally broken aluminium framing, the U-value can be substantially reduced.

Pilkington **Profilit**[™] Plus incorporates a hard pyrolytic surface coating - (low emissivity), which reduces heat loss through the glass and can provide in double glazing an optimal thermal insulation value of 1.8 W / m²K. The introduction of this coating with the thermally broken frame can also significantly reduce the incidence of condensation.

Safety

At Reglit Glass Architecture we ensure that every installation is assessed to identify any risk of breakage and personal injury and that the design complies with all applicable building regulations and standards. In conjunction with Pilkington, we continually undertake extensive testing of the product range to ensure that it meets the current safety standards and legislation.

The Pilkington **Profilit**[™] system, when installed in the appropriate formats, has been tested in accordance with BS 6206: 1981 and can give performance equivalent to Class B or Class C. Please refer to the Product Testing Section for further information on the test reports. If a performance equivalent to Class A is required please contact our Technical Department for details on thermally toughened glass.

Section 2 - PRODUCT DESCRIPTION

2.6 Performance Tables

Pilkington Profilit™	U- value in W/(m ² K)	g-value	Light - Transmission
Single glazed without coating	5.7	0.79	0.86
Double glazed without coating	2.8	0.68	0.75
Double glazed with Pilkington Profilit™ standard + Pilkington Profilit™ Plus 1,7	1.8	0.63	0.70
Double glazed with Pilkington Profilit™ standard + Pilkington Profilit™ Antisol	2.8	0.49	0.43
Double glazed with Pilkington Profilit™ Antisol + Pilkington Profilit™ Plus 1,7	1.8	0.45	0.41
Double glazed with Pilkington Profilit™ Amethyst	2.8	0.46	0.40
Double glazed with Pilkington Profilit™ Amethyst + Pilkington Profilit™ Plus 1,7	1.8	0.49	0.51
Double glazed with Pilkington Profilit™ Low Iron without coating	2.8	Contact technical department	

U_g Heat Transmission coefficient according to EN 673
g total radiation permeability according to EN 410

GLASS TYPES	SINGLE GLAZED		DOUBLE GLAZED	
	NP	SP	NP	SP
Sound Insulation RW Value(dB) (vertical)	22	25	38(1)	41(1)
U-Value (W/m ² k) Pilkington Profilit™ Standard Glass	5.6	5.52	2.8	2.7
U-Value (W/m ² k) Pilkington Profilit™ Plus Glass(2)			1.8(3)	1.8(3)
Light Transmission (Ave %) Pilkington Profilit™ Standard Glass	86%	86%	75%	75%
Heat Transmisson Pilkington Profilit™ Standard Glass	78%	78%	68%	68%

(1) These sound insulation figures are using PVC isolating gaskets. Without the gaskets the dB values are 36 and 40 respectively.

(2) Double glazed Pilkington **Profilit™** is compliant with Documents L and J if the Pilkington **Profilit™ Plus** glass is incorporated.

(3) The double glazed configuration consists of one plank of Pilkington **Profilit™ Plus** glass and one plank of Pilkington **Profilit™**.

Section 2 - PRODUCT DESCRIPTION

2.7 Testing

The Pilkington **Profilit™** Glazing System has been installed throughout the world for 40 years and has been tested in the United States, Great Britain and Germany. The main areas of testing have been: air permeability, water tightness and structural performance, sound reduction, thermal performance and impact resistance.

● Double-Glazed

Product testing was undertaken at the UKAS accredited testing laboratory - Taywood Engineering Ltd during August 2000. The system was tested in accordance with the Centre for Window and Cladding Technology (CWCT) Standard Test Methods for Curtain Walling.

The system specimen satisfied the following test requirements of the CWCT Standard:-

Air, water and Structural Performance

Air Permeability - 600 Pascals

Watertightness using static pressure - 600 Pascals

Watertightness using dynamic pressure - 600 Pascals

Wind resistance - serviceability and safety - 1300 Pascals

The system was also tested to the requirements of the new European Dynamic Watertightness Test – DD ENV 13050: 2001. **The system specimen satisfied the requirements for a design wind pressure of 1300 Pascals.**

● Single-Glazed

The test was carried out at UKAS accredited testing laboratory - Wintech Engineering Ltd. on a sample size of 2000mm x 2000mm.

Full CWCT test conducted on a sample panel and all requirements were met. A copy of the report is available on request.

● Impact Testing

The Pilkington **Profilit™** glazing system has been tested, by Pilkington plc and Reglit, using the test methodology as set out in BS 6206: 1981. . The tests subjected the Pilkington **Profilit™** glazing system to the pendulum impact test and then appraised the post impact performance, i.e. safe breakage, using the 76mm diameter sphere and the force gauge.

The following glass profiles installed in a double-glazed format satisfies the requirement of Part N (England and Wales) and Part P (Scotland) i.e. reducing the risk of cutting and piercing injuries, by either breaking safely during the test or not breaking at all.

Impacted at a drop height of 305mm – (Equivalent to BS 6206 Class C)

NP26 Double-Glazed 8 wires - Fitted with Impact Gasket

SP2 Double-Glazed 7 wires - Fitted with Impact Gasket

SP26 Double-Glazed 8 wires - Fitted with Impact Gasket

Impacted at drop heights of 305 and 457mm – (Equivalent to BS6206 Class B)

NP26 Double-Glazed 16 wires - Fitted with Impact Gasket

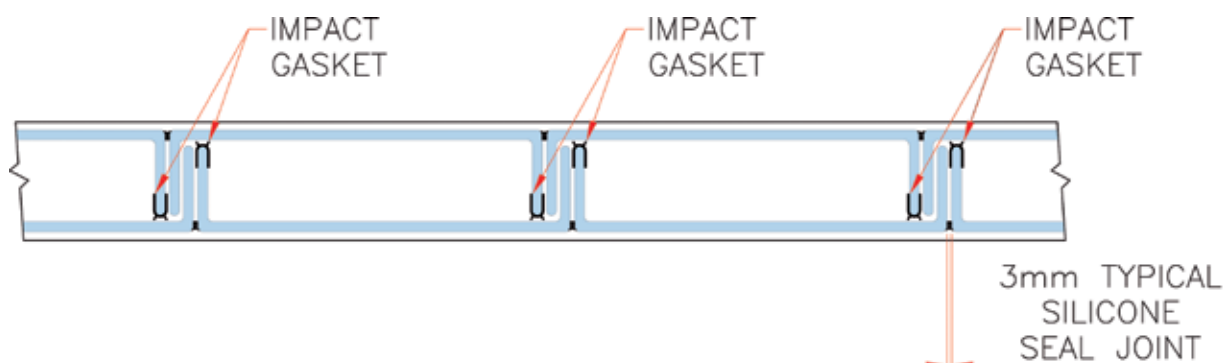

Section 2 - PRODUCT DESCRIPTION

2.8 Glass Finishes



Amethyst Unwired



Amethyst Wired



Cast 16 Wires



Cast Unwired



Cast Unwired
Antisol



Cast Unwired
Plus



Cast Unwired
Plus 17



Cast Unwired
Sandblasted



Cast Unwired
Sandblasted
Low Iron



Cast Wave



Cast Wired
Sandblasted
Low Iron



Clear Unwired



Clear Unwired
Sandblasted

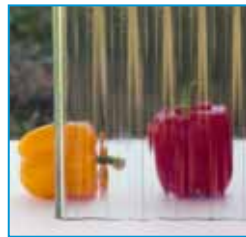

Clear Wave
Wired



Clear Wired



Wave Unwired
Sandblasted



Macro Sandblasted



Slimline



Slimline
Sandblasted



Wave Unwired
Low Iron

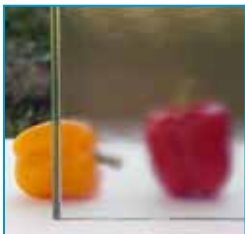

Macro



Cast Wired



Cast Unwired
Low Iron

Our glass is available in an almost infinite combination of finishes, above are some examples. For more information or to receive sample glass panels, please contact our technical department on 0141 613 6060.

Section 3 - SCHEDULE OF COMPONENTS

3.1 Normal Profile (NP) - Glass Profiles

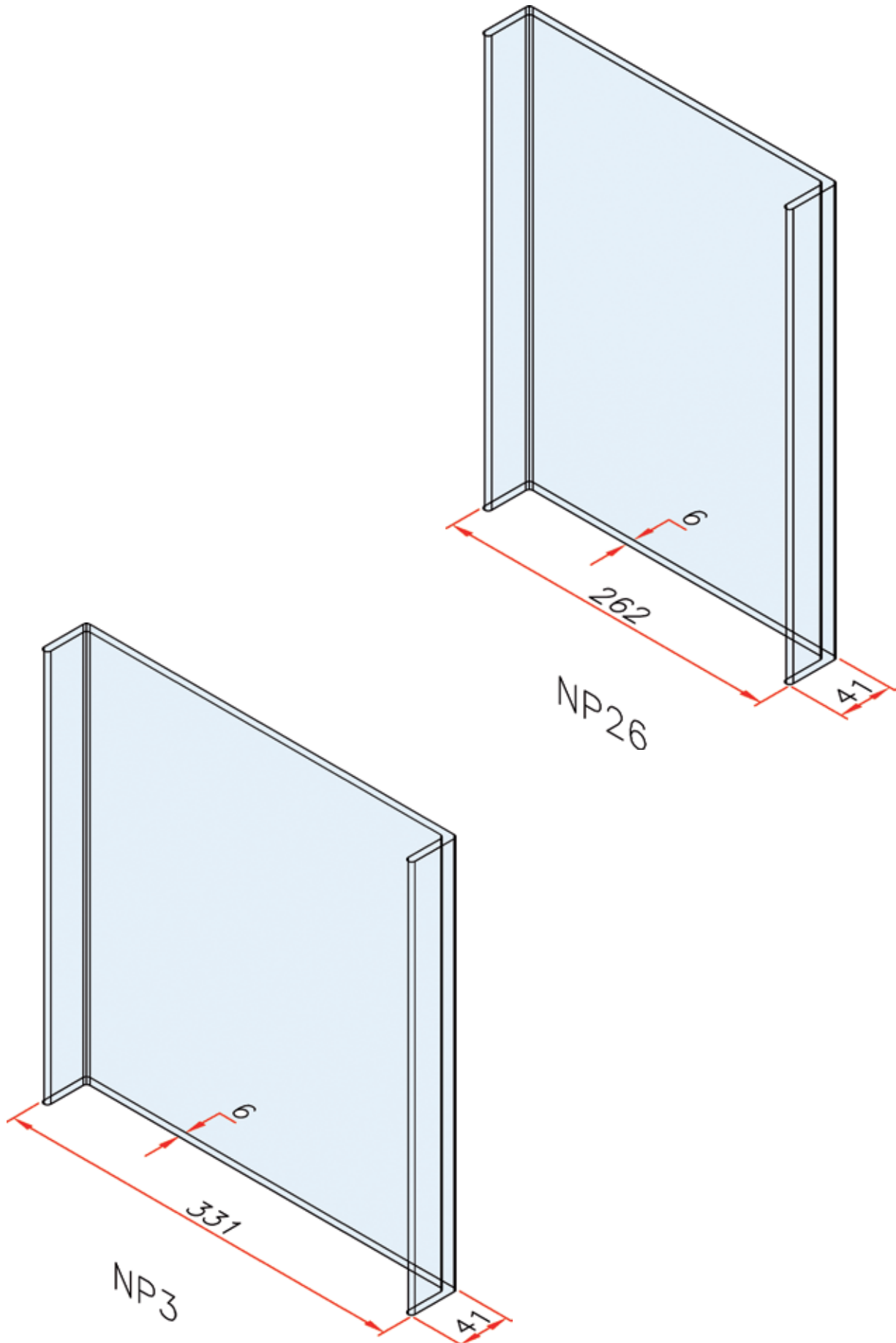

Section 3 - SCHEDULE OF COMPONENTS

3.2 Normal Profile (NP) - Aluminium Frames

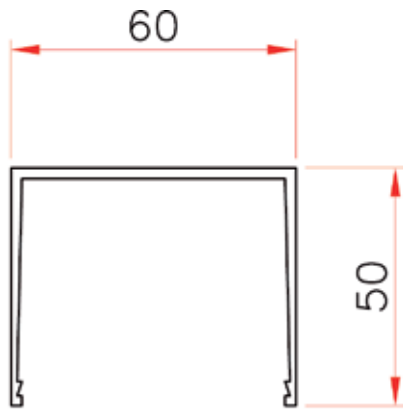

950S FRAME
HEAD, JAMB OR
CILL SECTION

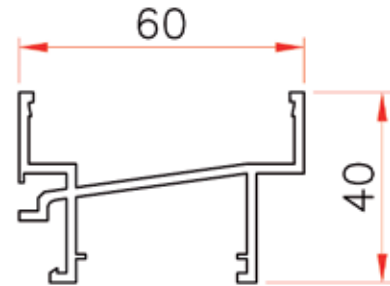

961 FRAME
CILL SECTION

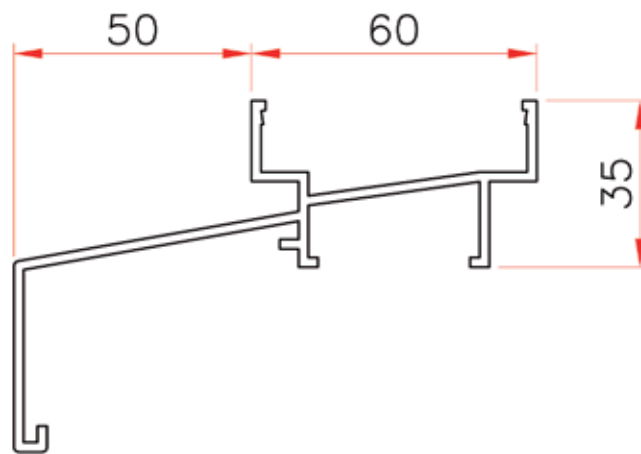

961/50 FRAME
CILL SECTION
ALSO AVAILABLE AS
961/80, 961/100,
961/120, 961/150
& 961/180.

Section 3 - SCHEDULE OF COMPONENTS

3.3 Normal Profile (NP) - Thermal Break Aluminium Frames

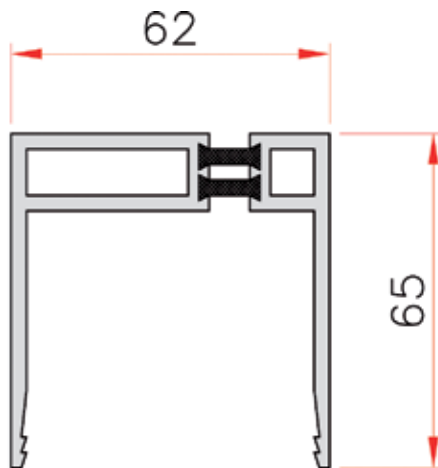

950TB FRAME
HEAD & JAMB SECTION
FOR VERTICAL GLAZING

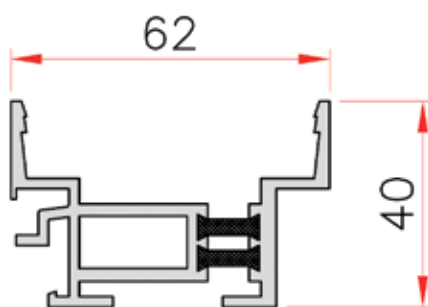

961TB FRAME
CILL SECTION
FOR VERTICAL GLAZING

Section 3 - SCHEDULE OF COMPONENTS

3.4 Special Profile (SP) - Glass Profiles

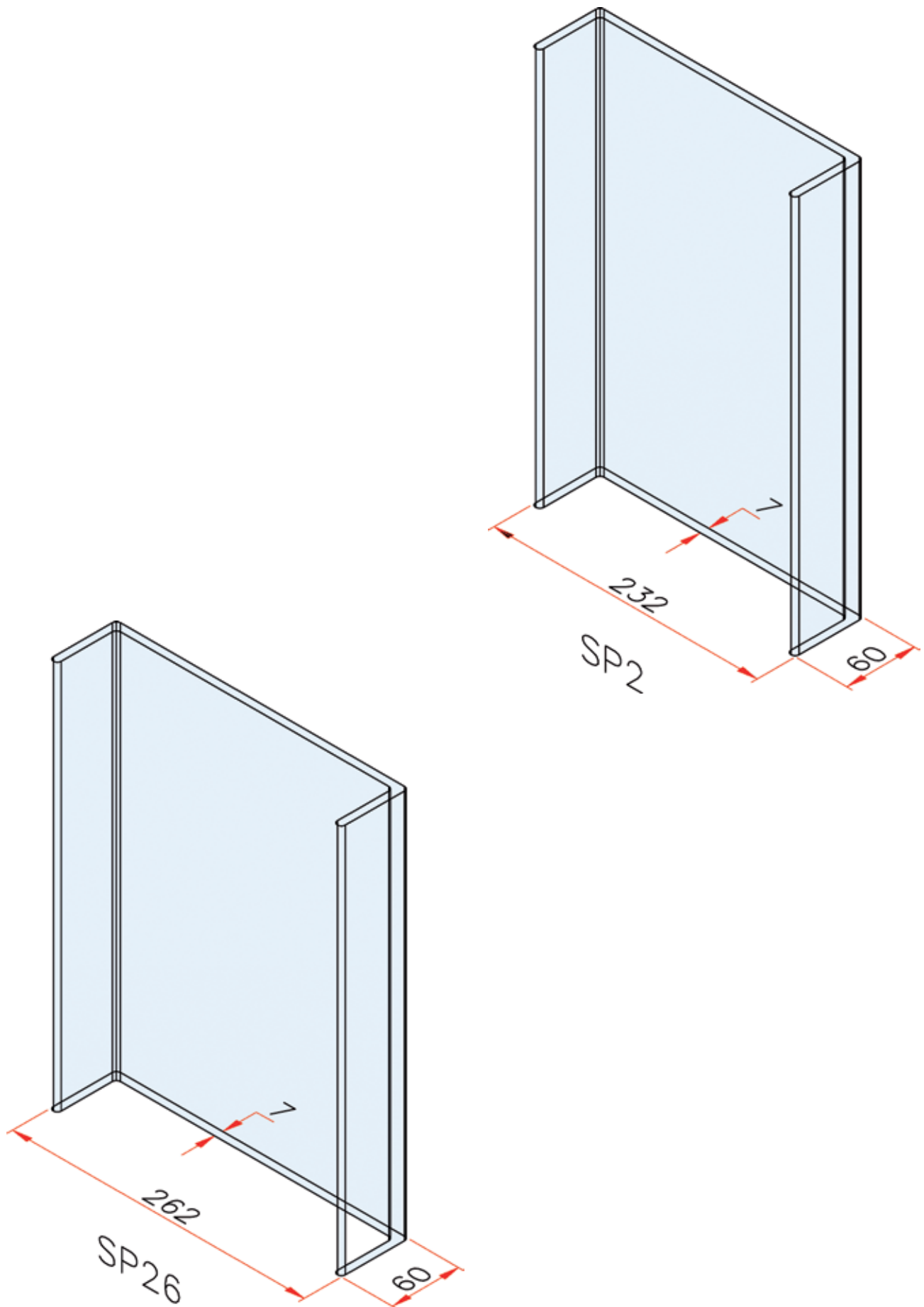

Section 3 - SCHEDULE OF COMPONENTS

3.5 Special Profile (SP) - Aluminium Frames

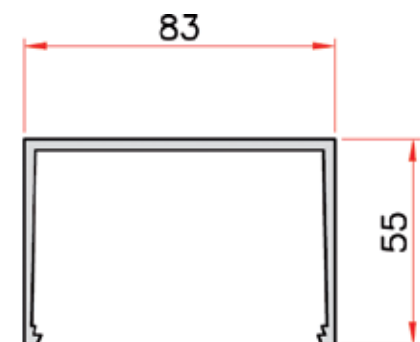

980 FRAME
HEAD, JAMB OR
CILL SECTION

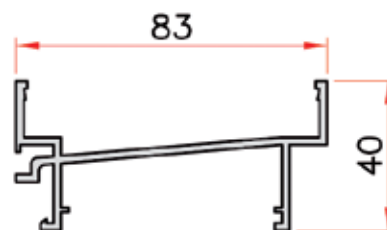

981 FRAME
CILL SECTION

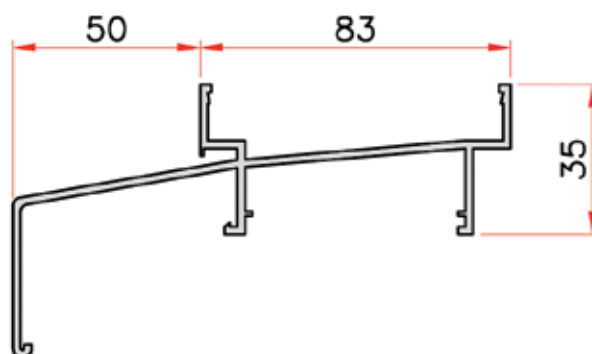

981/50 FRAME
CILL SECTION
ALSO AVAILABLE AS
961/100.

Section 3 - SCHEDULE OF COMPONENTS

3.6 Special Profile (SP) - Thermal Break Aluminium Frames

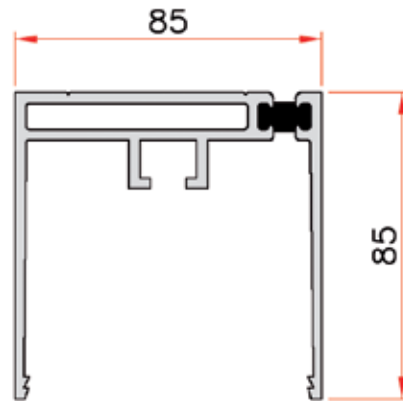

984TB FRAME
HEAD & JAMB FOR HORIZONTAL GLAZING
USED ON STRAIGHT SCREENS

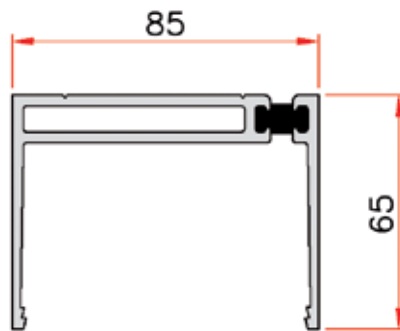

980CF FRAME
HEAD & JAMB FOR VERTICAL GLAZING
USED ON STRAIGHT SCREENS

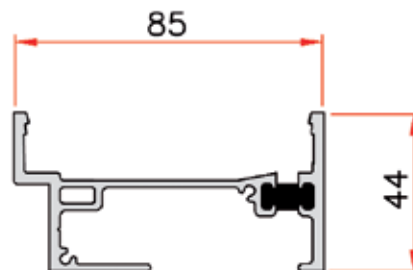

982CF FRAME
CILL FOR HORIZONTAL & VERTICAL GLAZING
USED ON STRAIGHT SCREENS

Section 3 - SCHEDULE OF COMPONENTS

3.6 Special Profile (SP) - Thermal Break Aluminium Frames (continued)

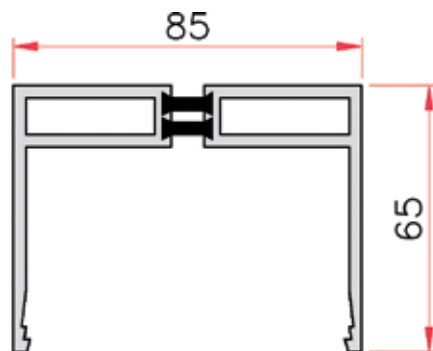

980TB FRAME
HEAD & JAMB FOR VERTICAL GLAZING
USED ON CURVED SCREENS

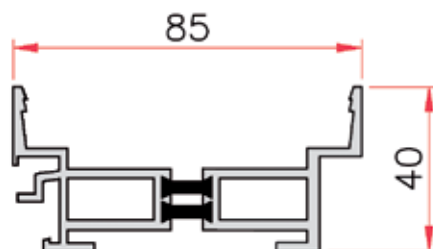

981TB FRAME
CILL FOR VERTICAL GLAZING
USED ON CURVED SCREENS

Section 3 - SCHEDULE OF COMPONENTS

3.7 Normal Profile (NP) - Plastic Insert

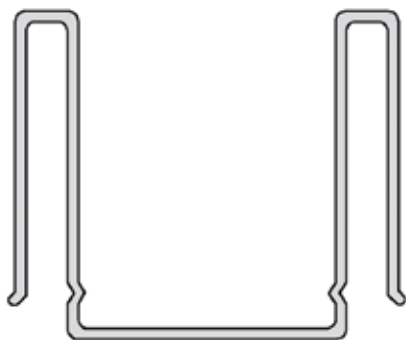

Type 962/2

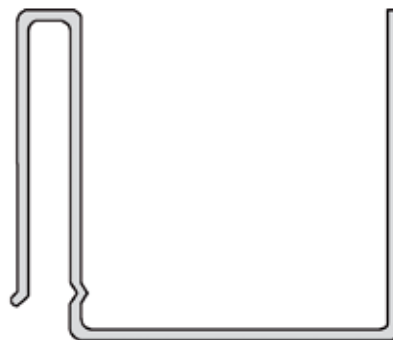

Type 962/1



Type 961/2



Type 961/1

3.7 Special Profile (SP) - Plastic Insert



Type 980/1

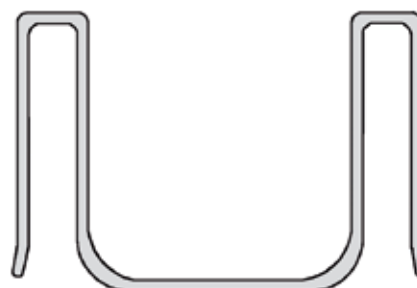

Type 980/2



Type 981/1



Type 981/2

Section 4 - INSTALLATION DESIGN OPTIONS

4.1 Installation Options

The installation of the Pilkington **Profilit**[™] system is a quick and simple process, with all components capable of being cut to size, efficiently reducing the site measurement time. Pilkington **Profilit**[™] can be installed in double or single glazed format in both vertical assemblies and horizontal assemblies.

Vertical Assembly – Double Glazing

By using this popular method, the main properties of the Pilkington **Profilit**[™] System can be realised, with large installation lengths, optimal U-values and maximum sound insulation levels being achievable.

With double-glazing, the inner and outer shell should be of the same profile, however by using different combinations of colours, pattern or sandblasting attractive architectural effects can be achieved.

When using Pilkington **Profilit**[™] Plus glass; this specially coated glass must be installed as the internal layer of the screen to achieve the required U-value.

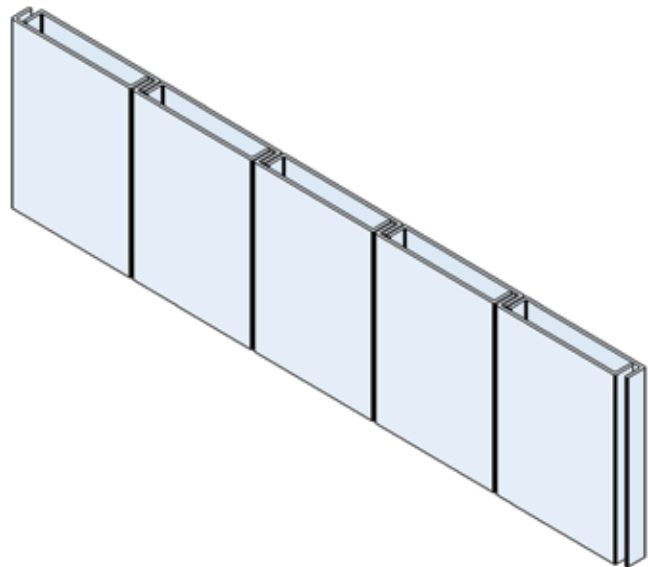

Vertical Assembly – Single Glazing

This method is the most economical and allows the maximum transmission of light into a building. However it is restricted in installation height and does not have efficient U-value properties or good acoustic values. It is primarily used as high-level clerestory glazing, with the flanges installed to the inside.

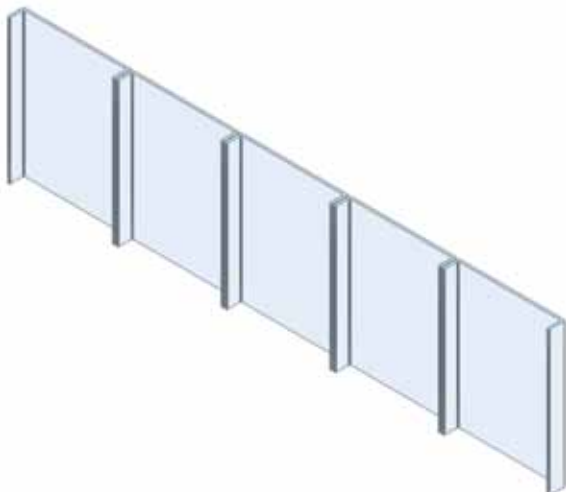

Section 4 - INSTALLATION DESIGN OPTIONS

Curved Glazing

Whether single or double-glazed, the Pilkington **Profilit**™ system can effectively create curved walls of glass. The channels are simply faceted into a curved aluminium framing.

The slimmer the glass panel used the more effective the appearance. Radii to a minimum of 2.5 metres can be achieved for internal applications. The use of a specially adapted framework allows radii of 1.6m to be achieved for external applications.

Please contact our Technical Department regarding the feasibility of particular projects via freedom@reglit.com.



Horizontal Assembly - Glazing

The horizontal assembly glazing method is an alternative but attractive installation technique where continuous vertical strips of glazing can be achieved e.g. staircase cladding.

The glass channels are installed horizontally constructing vertical strips of glazing without divisions; the glazing can be either single or double-glazed, with each channel supported separately within the periphery frame using an aluminium bracketed system.

In this installation format the dead load of the system is transferred to the structure via the vertical framework. For details see the Installation Details section.



Section 4 - INSTALLATION DESIGN OPTIONS

Glass Corners

With the double-glazed and single-glazed options, it is possible to construct all-glass corners. The glass corners are decorative, inexpensive and present no sealing problems, however, it must be borne in mind that corner and edge zones are subject to higher wind loads and appropriate design measures should therefore be taken into account.

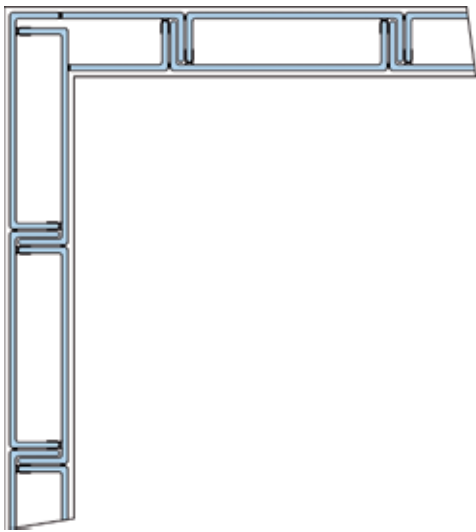

Wind Anchors

If the installation heights required are higher than the admissible installation height, a wind rail system may be fitted behind the glazed screen.

Secondary steelwork has to be fitted behind the glazing to absorb the horizontal wind forces. A specially designed wind anchor is used to anchor the Pilkington **Profilit**[™] glass planks to the wind rail.

Section 4 - INSTALLATION DESIGN OPTIONS

4.2 Admissible Span Design Charts

Wind pressure N/m ²	Maximum span for double glazing in metres				
	NP26	NP3	SP2	SP26	SP3
500	4.49	4.04	7.36	7.1	6.38
750	3.67	3.3	6.01	5.8	5.21
1000	3.18	2.85	5.21	5.02	4.51
1250	2.84	2.55	4.66	4.49	4.04
1500	2.59	2.33	4.25	4.1	3.69
1750	2.4	2.16	3.93	3.8	3.41
2000	2.25	2.02	3.68	3.55	3.19
2250	2.12	1.9	3.47	3.35	3.01
2500	2.01	1.81	3.29	3.18	2.86
3000	1.83	1.65	3.01	2.9	2.61

Wind pressure N/m ²	Maximum span for single glazing in metres				
	NP26	NP3	SP2	SP26	SP3
500	3.18	2.85	5.31	5.02	4.5
750	2.59	2.33	4.33	4.1	3.69
1000	2.25	2.02	3.75	3.55	3.19
1250	2.01	1.81	3.36	3.18	2.86
1500	1.83	1.64	3.06	2.9	2.61
1750	1.7	1.53	2.84	2.68	2.41
2000	1.59	1.43	2.65	2.51	2.26
2250	1.5	1.35	2.5	2.37	2.13
2500	1.42	1.28	2.37	2.25	2.02
3000	1.3	1.17	2.17	2.05	1.84

These tables give the maximum installation lengths in metres for vertically installed Pilkington **Profilit**[™] Glass within closed buildings. These figures should be used as a guide only; all design details should be confirmed by Reglit Glass Architecture's technical department.

If greater lengths are required wind anchors are available.

Horizontal double glazed wired

	NP26	SP2	SP26
Wind Pressure			
600	3.5	4.5	4.5
1000	3.5	4.5	4.5
2000	2.5	4	3.75

This table gives the maximum installation lengths in metres for horizontally installed Pilkington **Profilit**[™] wired glass within closed buildings. These figures should be used as a guide only; all design details should be confirmed by Reglit Glass Architecture's Technical Department.

Please Note:

These installation lengths may be subject to change. We would recommend contacting our Technical Department via freedom@reglit.com to confirm installation lengths for individual projects.

Section 5 - INSTALLATION DETAILS

5.1 Normal Profile (NP) Head and Base Details – For Internal Glazing

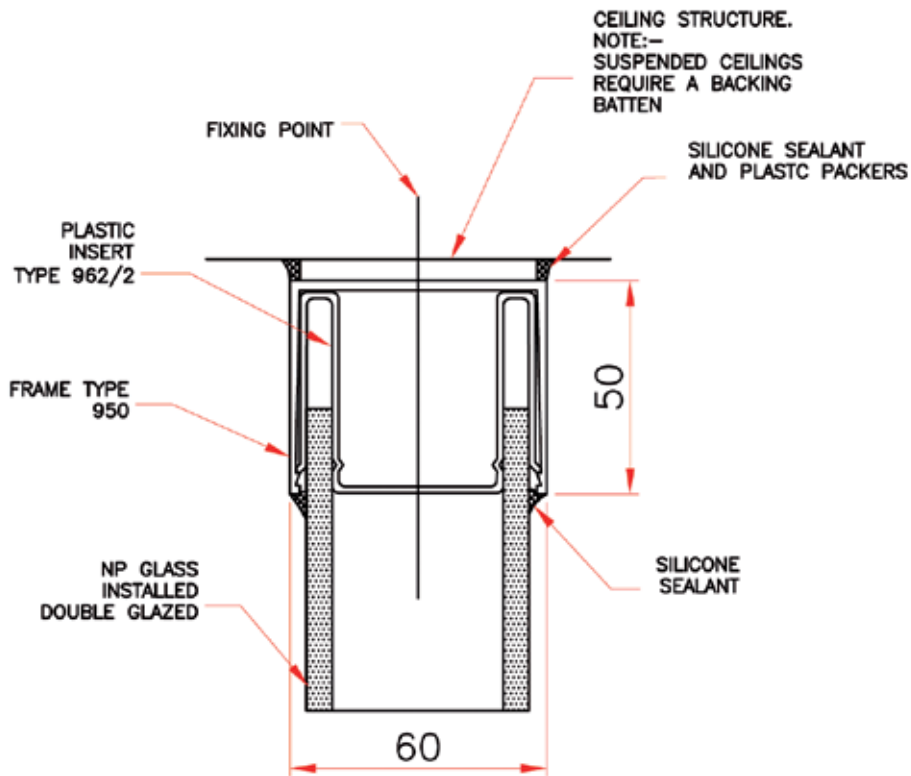

HEAD DETAIL

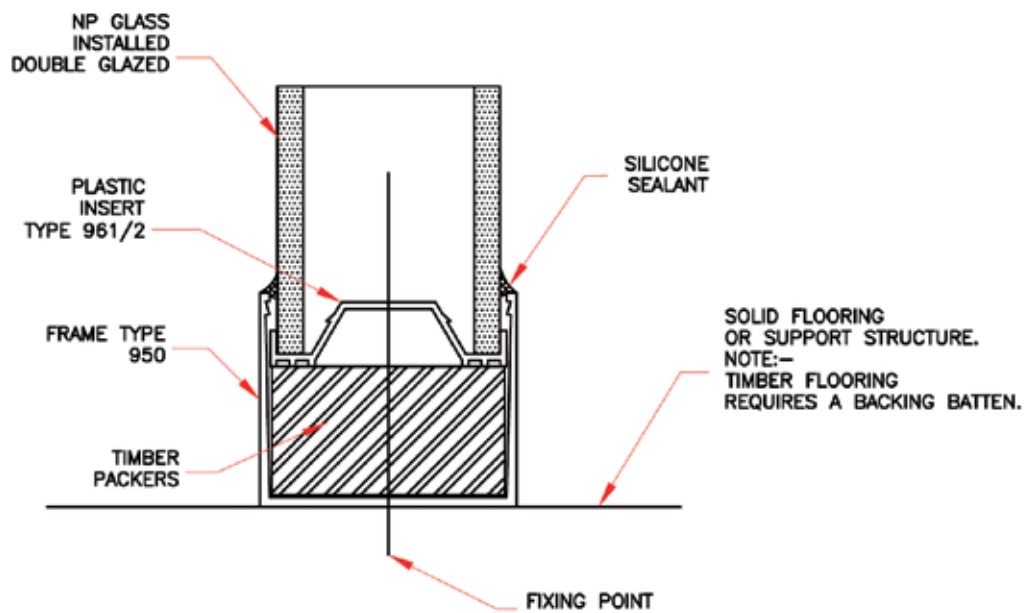

CILL DETAIL

Section 5 - INSTALLATION DETAILS

5.2 Normal Profile (NP) Jamb Detail – For Internal Glazing

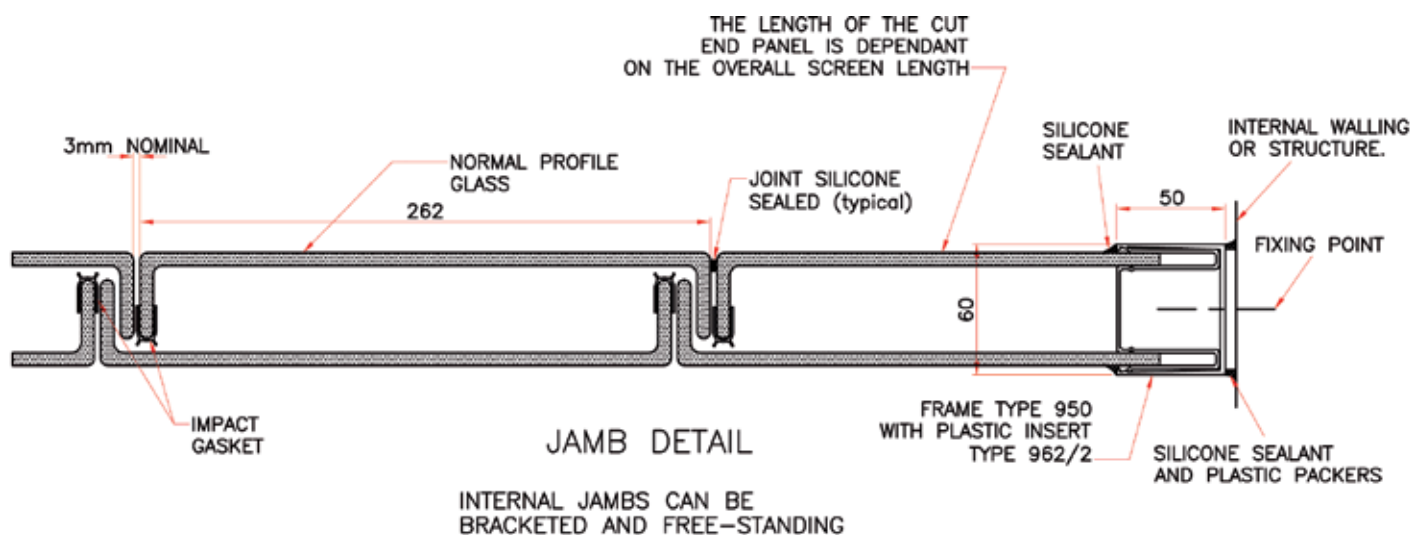

Section 5 - INSTALLATION DETAILS

5.3 Normal Profile (NP) Head and Base Details – Thermally Broken For External Glazing

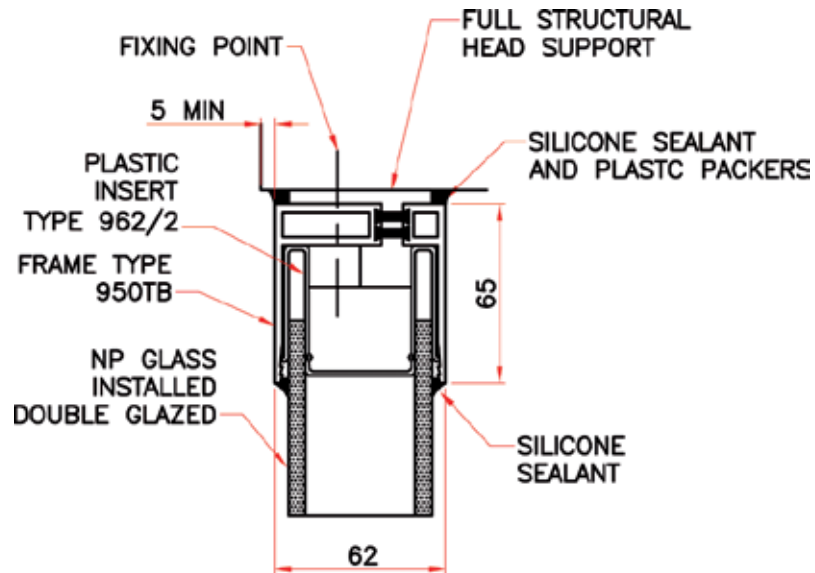

HEAD DETAIL

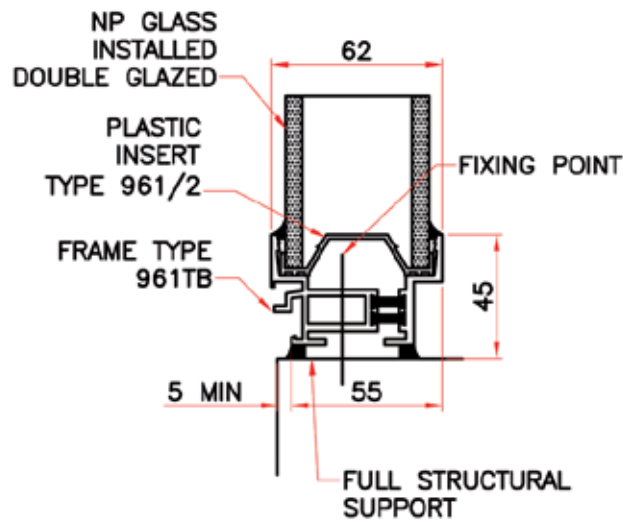

CILL DETAIL

Section 5 - INSTALLATION DETAILS

5.4 Normal Profile (NP) Jamb Detail – Thermally Broken For External Glazing

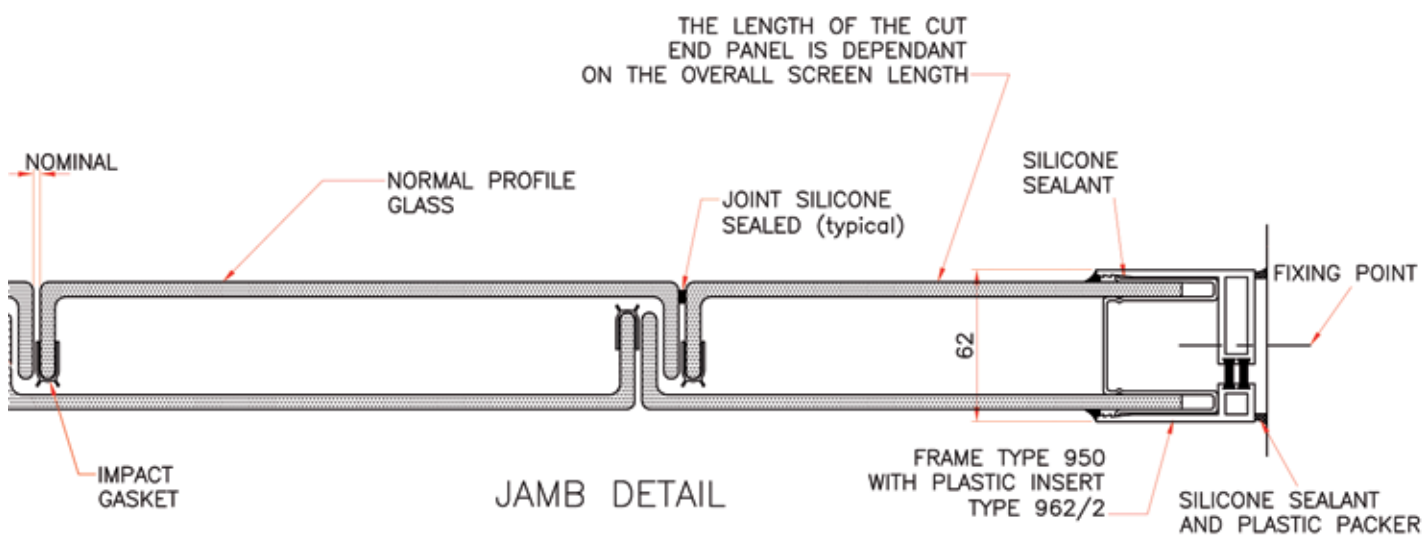

Section 5 - INSTALLATION DETAILS

5.5 Special Profile (SP) Head and Base Details – Thermally Broken For External Glazing

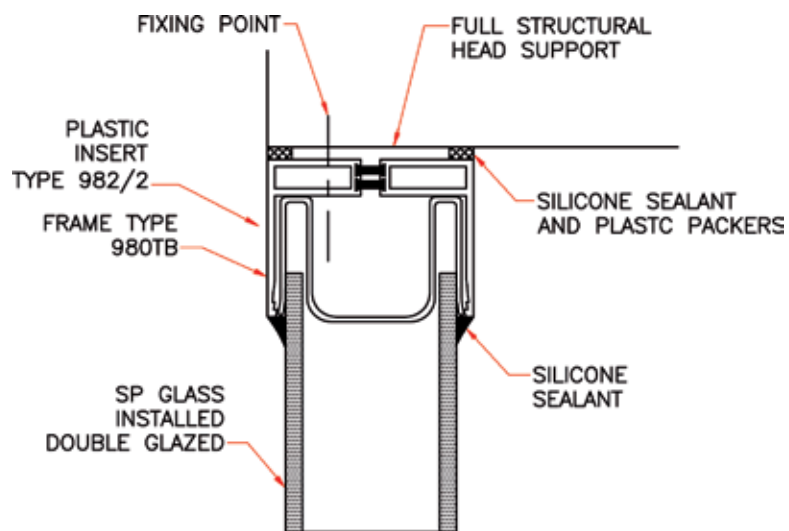

HEAD DETAIL

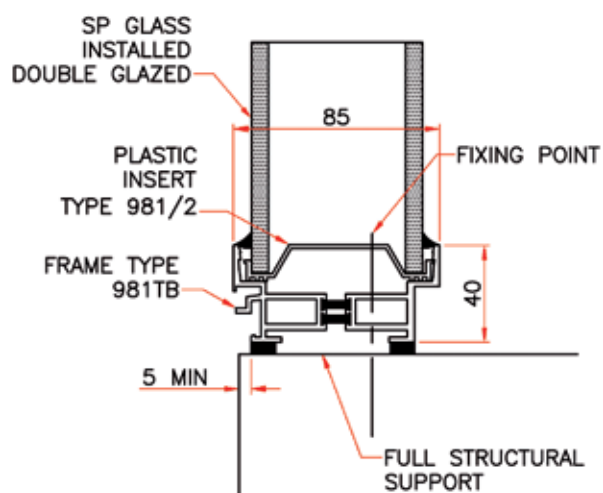

CILL DETAIL

Section 5 - INSTALLATION DETAILS

5.6 Special Profile (SP) Jamb Detail – For External Glazing

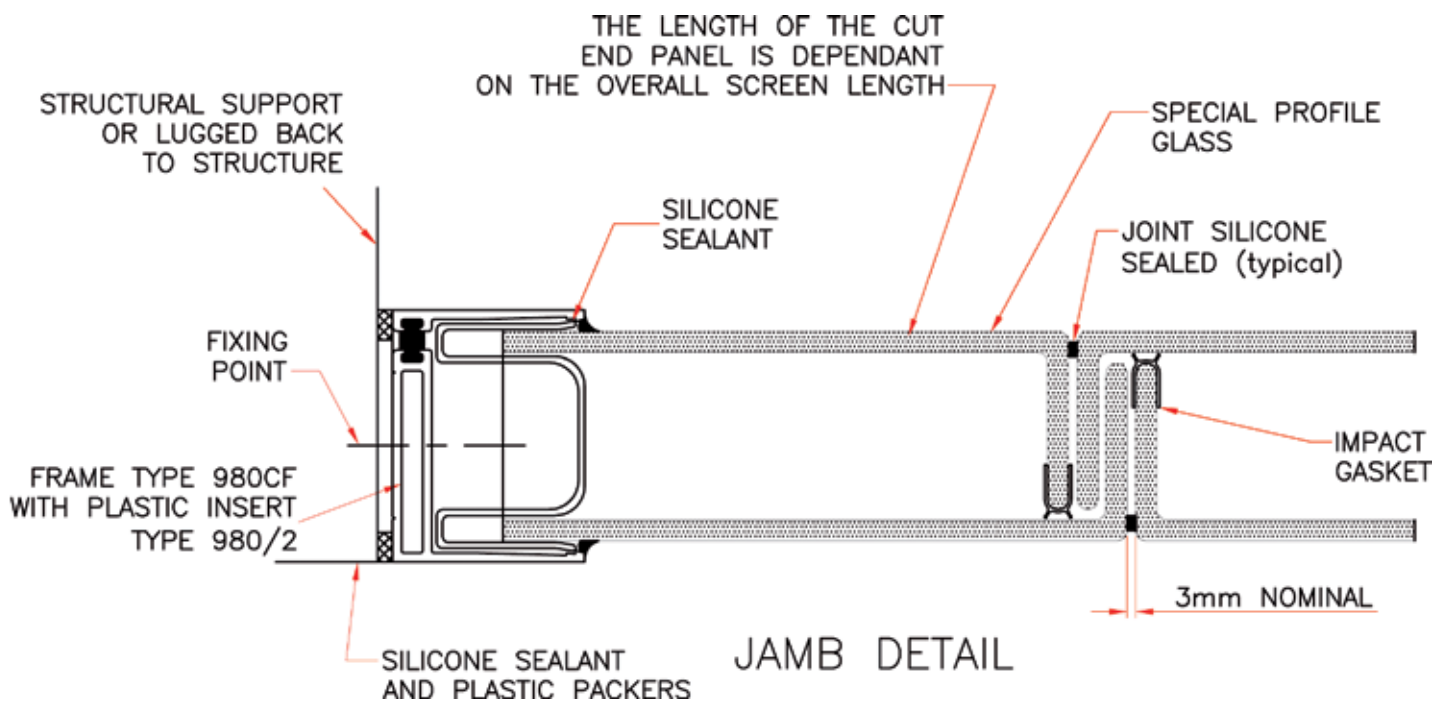

Section 5 - INSTALLATION DETAILS

5.7 Special Profile (SP) Horizontal Base Detail – For External Glazing

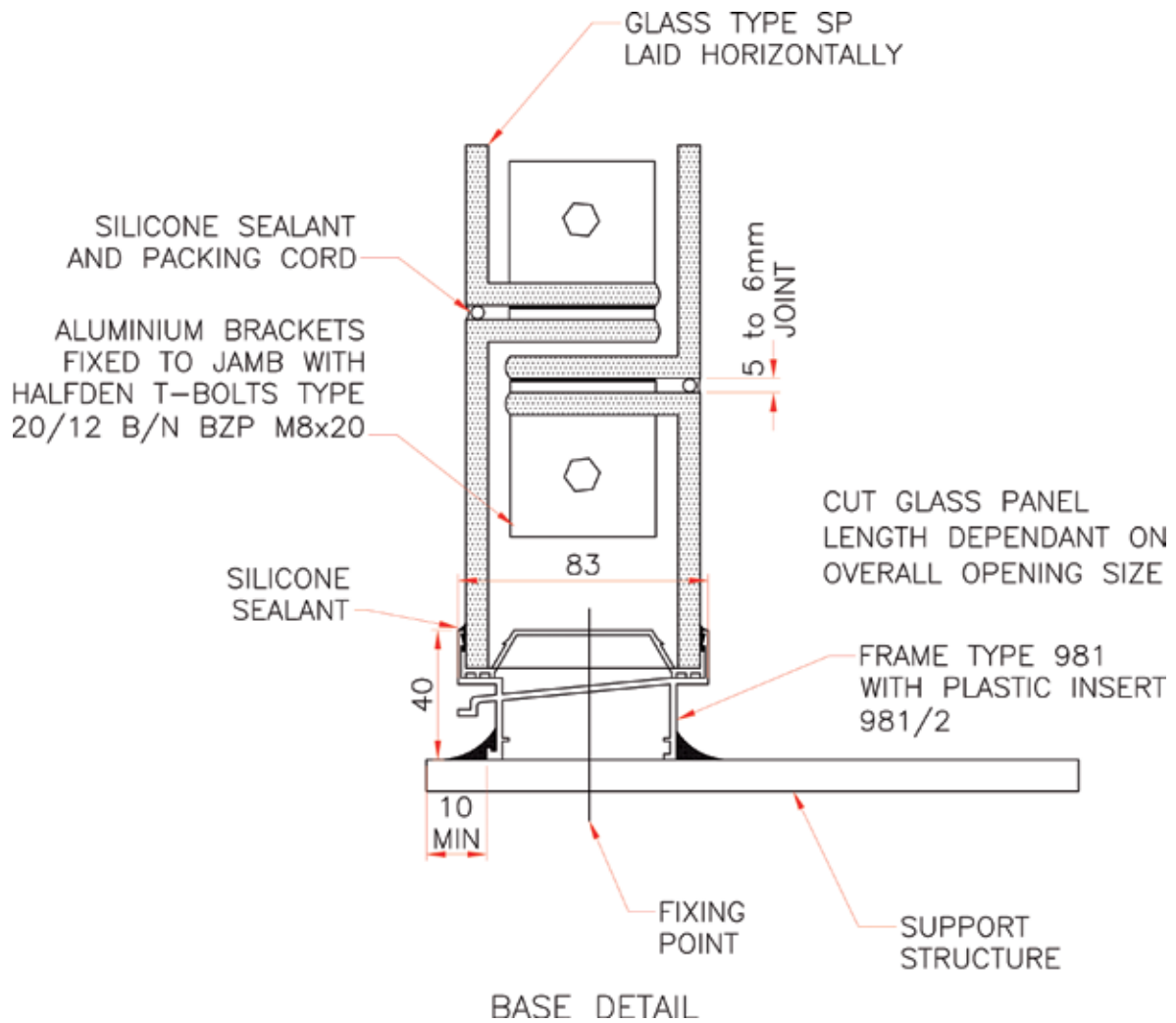

Section 5 - INSTALLATION DETAILS

5.8 Special Profile (SP) Horizontal Head Detail – For External Glazing

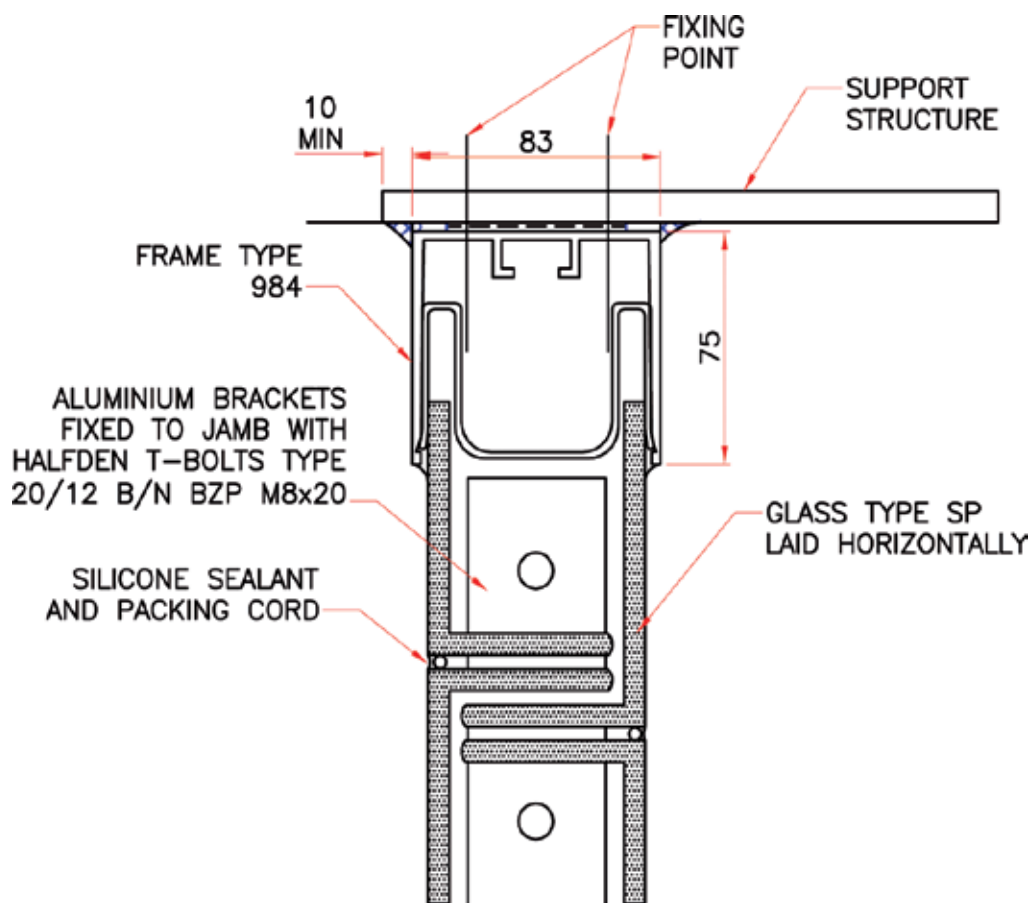

HEAD DETAIL

Section 5 - INSTALLATION DETAILS

5.9 Special Profile (SP) Horizontal Jamb Detail – For External Glazing

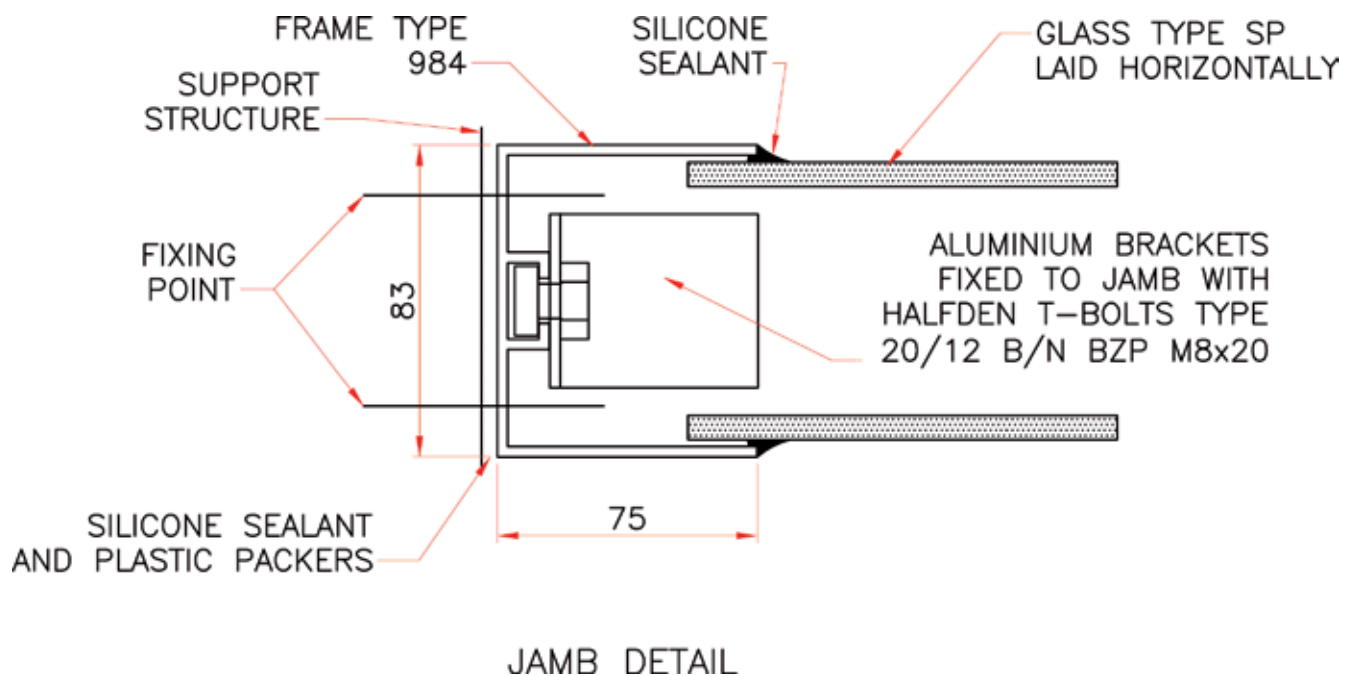

Section 6 - SPECIFICATIONS

6.1 For Use in Internal Partitions

H13 STRUCTURAL GLASS ASSEMBLIES - For Use in Internal Partitions

To be read with Preliminaries / General Conditions

Type(s) of Glass Assembly: Pilkington **Profilit™** Glazing System

Drawing references: Architect's drawings.

Supporting structure: As shown on Engineers drawings.

System type: Glass type - NP26 wired, <glass colour and finish>¹ with <number>² number stainless steel wires, installed double-glazed with impact gasket type 166. Glass manufactured in accordance with EN 572-7.

Glass channel size: 262 x 41 x 6mm thick.
Aluminium frame type: 950 to head, base and jamb.
Plastic insert types: 961/2 to base.
962/2 to head and jamb.

Manufacturer: Pilkington Bauglasindustrie

Distributed By: Reglit Glass Architecture

E- mail: freedom@reglit.com
Web site: www.reglit.com

Impact resistance: Installed system must meet the requirements for glazing in critical locations as stipulated within Approved Document N of the England & Wales Building Regulations.

Fire resistance: No rating required.

Method of assembly: Pilkington **Profilit™** glass channels fitted vertically with impact gasket type 166, double-glazed into proprietary aluminium perimeter framing system.

Aluminium frame to be fixed to the support structure, around full extent of structural opening.

All materials to be site cut. All glass to glass; glass to aluminium joints to be sealed with silicone sealant. Glazing system to be installed in conjunction with the manufacturer's recommendations.

Weight: 45 kg/m²

1 Glass colour and finish - for example, Blue Amethyst, Clear, Clear Amethyst and sand-blasted
2 The glass has been tested in the double-glazed format using the methodology of BS6206: 1981. The impact performance is dependant upon the number of wires.

For 305mm drop height –	(Equivalent to Class C)	8 number wires
For 457mm drop height –	(Equivalent to Class B)	16 number wires
For 1219mm drop height –	(Equivalent to Class A)	Please contact Reglit Glass Architecture's Technical Department.

Section 6 - SPECIFICATIONS

6.2 For Use in External Screens

H13 STRUCTURAL GLASS ASSEMBLIES - For Use in External Screens

To be read with Preliminaries / General Conditions

Type(s) of Glass Assembly. Pilkington **Profilit™** Glazing System

Drawing references: Architect's drawings.

Supporting structure: As shown on Engineers drawings.
System type: Glass type SP26 wired, <glass colour and finish>³ with <number>⁴ number stainless steel wires, installed double-glazed with impact gasket type 166.
Glass manufactured in accordance with EN 572-7.

Glass channel size: 262 x 60 x 7mm thick.
Aluminium frame type: 980 to head and jamb. 981/50 to base.
Plastic insert types: 981/2 to base.
980/2 to head and jamb.

Manufacturer: Pilkington Bauglasindustrie

Distributed By: Reglit Glass Architecture

E- mail: freedom@reglit.com
Web site: www.reglit.com

Impact resistance: Installed system must meet the requirements for glazing in critical locations as stipulated within Approved Document N of the England & Wales Building Regulations.

Fire resistance: No rating required.

Method of assembly: Pilkington **Profilit™** glass channels fitted vertically with impact gasket type 166, double-glazed into proprietary aluminium perimeter framing system. Aluminium frame to be fixed to the support structure, around full extent of structural opening. All materials to be site cut. All glass to glass; glass to aluminium joints to be sealed with silicone sealant. Glazing system to be installed in conjunction with the manufacturer's recommendations.

Weight: 60 kg/m²

Weather resistance: External glazing, including jointing and fixing, must be wind and water tight under all conditions with full allowance made for permissible deflections. Integrity Calculate glass sizes, thickness, spans, frame types and location of fixings in accordance with manufacturer's recommendation and BS6399: Part 2:1997 Standard Method (making due allowance for any internal pressure) to ensure that the glazing will resist all dead loads and design live loads, and accommodate all deflections and thermal movements without damage. For admissible spans see the Design Installation Options Section.

3 Glass colour and finish - for example, Blue Amethyst, Plus, Clear Amethyst and sand-blasted
4 The glass has been tested in the double-glazed format using the methodology of BS6206: 1981. The impact performance is dependant upon the number of wires.

For 305mm drop height –	(Equivalent to Class C)	8 number wires
For 457mm drop height –	(Equivalent to Class B)	16 number wires
For 1219mm drop height –	(Equivalent to Class A)	Please contact Reglit Glass Architecture's Technical Department.

Section 7 - BIBLIOGRAPHY

BSEN 572 – 7: 2004; Glass in building – Basic soda lime silicate glass product – Part 7: Wired or unwired channel shaped glass

BSEN 572 – 9: 2004; Glass in building – Basic soda lime silicate glass product – Part 9: Evaluation of conformity/Product standard

BS 6206: 1981; Specification for the impact performance requirements for flat safety glass and safety plastics for use in buildings

BS 6399 – 2: 1997; Loading for buildings – Part 2: Code of practice for wind loads

DD ENV 13050: 2001 – Curtain walling. - Water tightness. - Laboratory test under dynamic condition of air pressure and water spray

EN 410; Glass in building – Determination of levels and solar characteristics of glazing

EN 673; Glass in building – Determination of thermal transmission.

EN 1096 -1; (U-Values) – Calculation method

EN 1096 - 4; Glass in building – Coated Glass - Part 4 evaluation of conformity / product standard Part 1 glass building coated glass, Part 1 Deformation and classification.

Photography

Cover - Elmgrove House, Architect Alan Camp Architects, Contractor Galliford Try Partnership, Photographer Simon Warren.

Page 3 - Imperial College London, Architect AEM Studios, Contractor Interior plc.

Page 5 - Southbank Youth Centre London, Architect London Borough of Lambeth.

Page 20 - North Hertfordshire College Stevenage, Architect Dyer Associates, Contractor Wilmot Dixon Construction, © David Barbour and Dyer Associates.

Page 20 - Airbus Assembly Centre Broughton Flintshire, Architects Faulkner Browns, Contractor Laing O'Rourke, © Ian Lawson & Faulkner Browns.

Page 21 - Tabard Square, Architects Rolfe Judd, Contractor Laing O'Rourke, Photographer Simon Warren.

Page 21 - Arsenal Emirates Stadium, Architects HOK Sports, Contractor Sir Robert McAlpine, Photographer Simon Warren.

Ashbury House
6 Ashton Road
Rutherglen
Glasgow
G73 1UB
Scotland

t. +44 (0)141 613 6060 f. +44 (0)141 613 6061

www.reglit.com

freedom@reglit.com