

PROJECT REF:	STAND RANGE
UNIT REF:	N/A
FOOT PRESSURE:	N/A
UDL:	N/A

Material grade: BS EN 10219-1:2006 (S235JR). Welding standard: BS EN ISO 15614-1. Galvanizing standard: BS EN ISO 1461:2009  
Reference specification document "Custom Fabrication Specification" (BF-SPEC-050411) for further information

		Mini Split Stand Range						VRF/VRV Stand Range							
Part Number		B5550	B5551	B5552	B5553	B5554	B5555	B5562	B5556	B5557	B5558	B5559	B5560	B5561	
Description		Mini Split Low	Mini Split High	Mini Split Tower	MS Low Extension	MS High Extension	MS Riser Kit 4 Pack	MS Riser Kit 2 Pack	VRF/VRV 990	VRF/VRV 1290	VRF/VRV 1450	VRF/VRV 990 Extension	VRF/VRV 1290 Extension	VRF/VRV 1450 Extension	
Number of Feet		4	4	4	2	2	-	-	4	4	4	2	2	2	
A	Overall Length	mm	700	700	700	1060	1060	n/a	n/a	1230	1530	1690	1030	1330	1490
		inches	27 9/16	27 9/16	27 9/16	41 3/4	41 3/4	n/a	n/a	48 1/2	60 1/4	66 1/2	40 1/2	52 3/8	58 5/8
B	Overall Width	mm	1125	1125	1125	1125	1125	n/a	n/a	1360	1360	1360	1360	1360	1360
		inches	44 1/4	44 1/4	44 1/4	44 1/4	44 1/4	n/a	n/a	53 1/2	53 1/2	53 1/2	53 1/2	53 1/2	53 1/2
C	Distance Between Feet	mm	300	300	300	775	775	n/a	n/a	830	1130	1290	830	1130	1290
		inches	11 13/16	11 13/16	11 13/16	30 1/2	30 1/2	n/a	n/a	32 5/8	44 1/2	50 3/4	32 5/8	44 1/2	50 3/4
D	Crossbar Length	mm	475	475	475	950	950	n/a	n/a	990	1290	1450	990	1290	1450
		inches	18 11/16	18 11/16	18 11/16	37 2/5	37 2/5	n/a	n/a	39	50 3/4	57	32 5/8	44 1/2	50 3/4
	Height	mm	305	450	305/1000	305	450	152	152	305	305	305	305	305	305
		inches	12	17 11/16	12/39 3/8	12	17 11/16	6	6	12	12	12	12	12	12
	Frame Weight	kg	20	22	35	18	19	1.5	0.75	35	38	41	25	28	31
		lbs	44	49	77	40	42	3	2	77	84	90	55	62	68
	Design Load	kg	175	175	300	175	175	-	-	600	500	400	600	500	400
		lbs	385	385	661	385	385	-	-	1323	1102	882	1323	1102	882

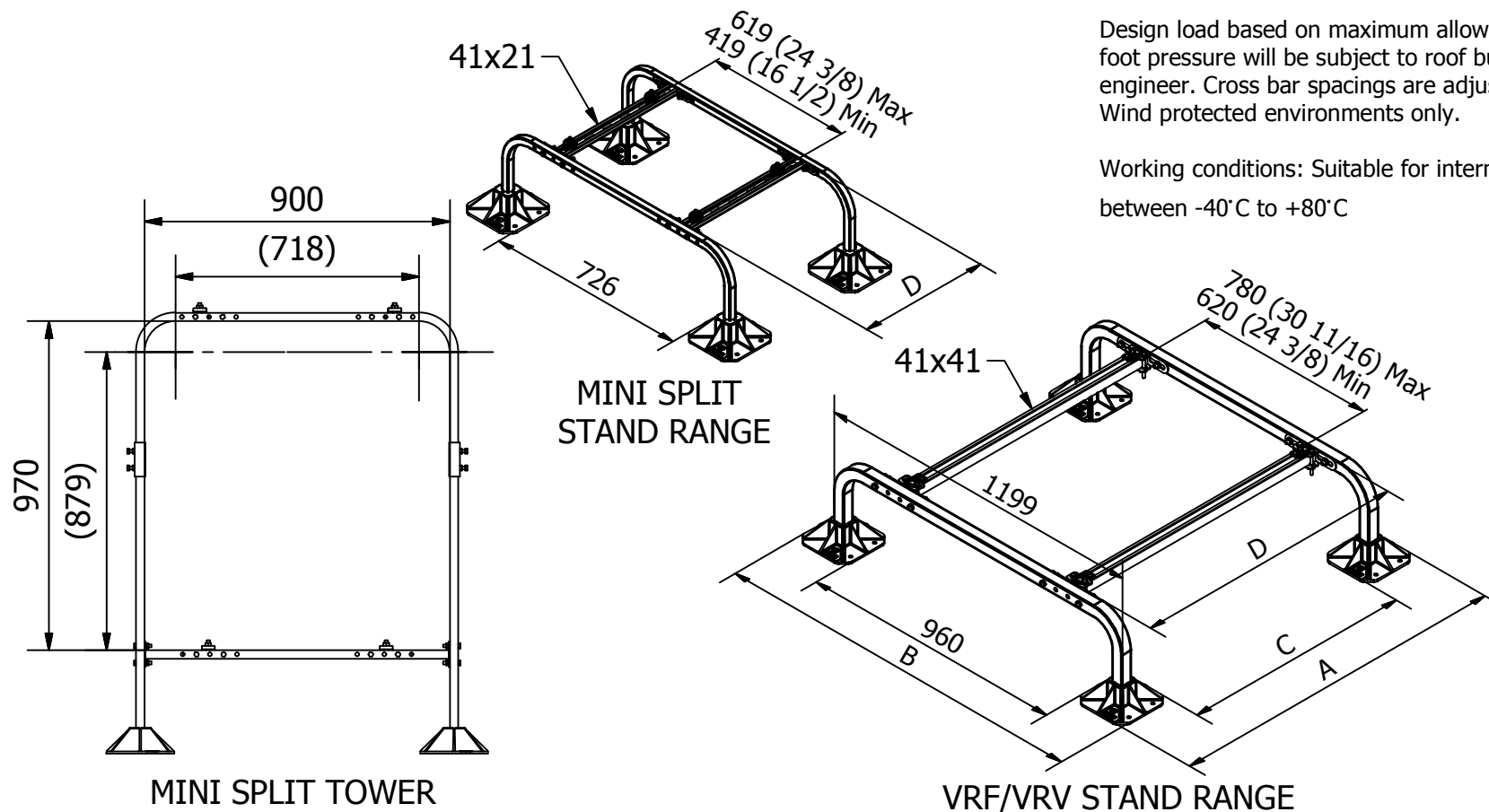
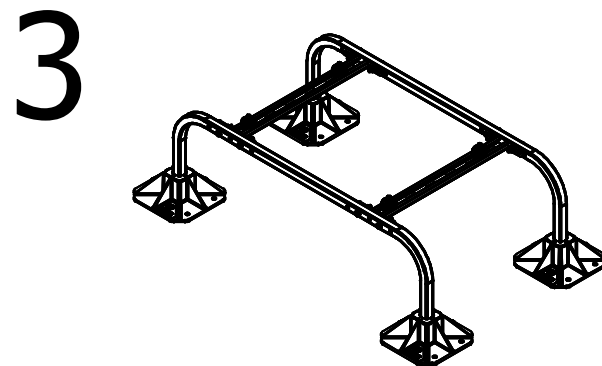
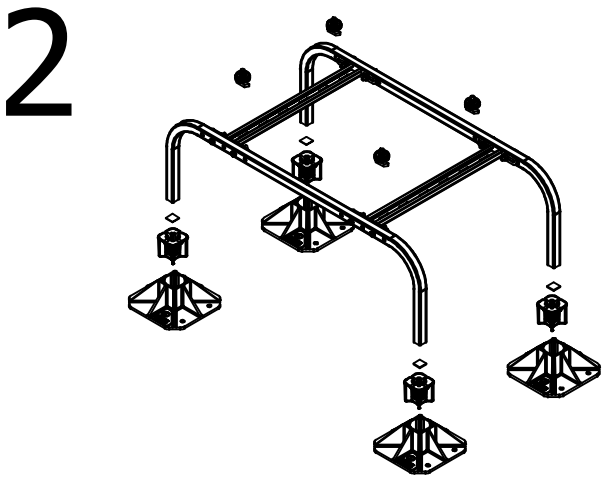
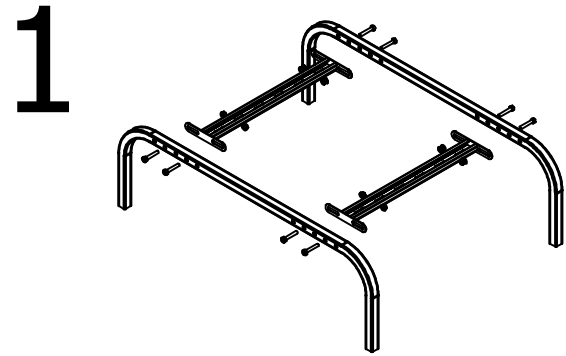

Design load based on maximum allowable deflection on cross members. Allowable foot pressure will be subject to roof build-up, typically detailed by a structural engineer. Cross bar spacings are adjustable to accommodate various unit sizes. Wind protected environments only.

Working conditions: Suitable for internal or external applications in temperatures between -40°C to +80°C



13 (x2) & 17mm  
30Nm on frame bolts  
10Nm on unit mounting bolts

Installation and application considerations should include health, safety and environmental needs, regulations and standards, codes of practice, climate conditions, installation location, product orientation, evaluation of the roof structure, composition, surface and condition, ancillary and complimentary products and materials. Big Foot Systems recommend that all rooftop products are handled and installed by suitably qualified persons. All scheme designs are based on the use of Big Foot Systems' products and materials only. Terms and conditions available on request

REV	DATE:	19/10/2016	SCALE: 1 : 15	A3
	DRAWN:	A SIMMANS		
	CHECKED:	S BIRCH		
			DIMENSIONS IN mm U.O.S	
			TOLERANCES: 0.0 ± 0.5mm U.O.S	
			SHEET 1 OF 1	

TITLE:	Stand Range Product Information Sheet
DWG No.	BFP-SR.dwg
THIS DRAWING IS COPYRIGHT AND THE PROPERTY OF BIG FOOT SYSTEMS LIMITED	

