

# Data Sheet

2016 v1.0

## SMARTRAIL X835 DIN Rail Multifunction Power Meter

- Single & Three Phase Networks
- Import / Export kWh
- Built In Pulsed Outputs
- Built In RS485 Modbus RTU
- 1A or 5A Programmable CT Input



## SMARTRAIL X835 Multifunction Power Meter

The SMARTRAIL X835 is a new generation modern design power monitor that will measure and display electrical power quality parameters. It has been engineered to cover most applications (Single Phase and Three Phase networks / Built in Pulsed and RS485 Modbus / Import and Export kWh), replacing the need for several different models of this power meter.

The SMARTRAIL X835 is produced to the highest quality and utilizes the latest microprocessor and technology. It has a blue backlit display and 16 different measuring parameters. This includes a negative power reading to indicate reversal of CT installation or connection. With built in pulsed outputs and RS485 Modbus RTU it is fully compatible for integration with BMS and remote monitoring systems.

This specific model from the SMARTRAIL range is configured to work in conjunction with a configurable 1A or 5A CT secondary.

## Parameters

- Phase to Neutral Voltage (V)
- Phase Current (A)
- Voltage Total Harmonic Distortion (U%THD)
- Current Total Harmonic Distortion (I%THD)
- Frequency (Hz)
- Power Factor (PF)
- Current Max Demand (MD A)
- Power Max Demand (MD kW)
- Active Power (kW)
- Reactive Power (kVAR)
- Apparent Power (kVA)
- Import Active Energy (kWh)
- Export Active Energy (kWh)
- Total Active Energy (kWh)
- Import Reactive Energy (kVARh)
- Export Reactive Energy (kVARh)
- Total Reactive Energy (kVARh)

# Specifications

## Measured Parameters

The unit can monitor and display the following parameters of a single phase two wire (1P2W), three phase three wire (3P3W) or three phase four wire (3P4W) system.

## Voltage and Current

- Phase to neutral voltages 100 to 289V AC (not for 3P3W supplies).
- Voltages between phases 173 to 500V AC (3p supplies only).
- Percentage total voltage harmonic distortion (THD%) for each phase to N ( not for 3P3W supplies).
- Percentage voltage THD% between phases (three phase supplies only).
- Current THD% for each phase

## Power factor and Frequency and Max. Demand

- Frequency in Hz
- Instantaneous power:
- Power 0 to 3600 MW
- Reactive power 0 to 3600 MVar
- Volt-amps 0 to 3600 MVA
- Maximum demanded power since last Demand reset Power factor
- Maximum neutral demand current, since the last Demand reset (for three phase supplies only)

## Energy Measurements

Imported/Exported active energy	0 to 9999999.9 kWh
Imported/Exported reactive energy	0 to 9999999.9 kVarh
Total active energy	0 to 9999999.9 kWh
Total reactive energy	0 to 9999999.9 kVarh

## Measured Inputs

Voltage inputs through 4-way fixed connector with 2.5mm<sup>2</sup> stranded wire capacity. single phase two wire(1P2W), three phase three wire(3P3W) or three phase four wire(3P4W) unbalanced. Line frequency measured from L1 voltage or L3 voltage. Three current inputs (six physical terminals) with 2.5mm<sup>2</sup> stranded wire capacity for connection of external CTs. Nominal rated input current 5A or 1A AC Rms.

Nominal Voltage Input	(Ph+N) 100 to 289V (Ph+Ph) 173 to 500V
Max Continuous Voltage	120% of nominal
Nominal Input Current	0.25-5A(6)A AC rms
Max Continuous Current	120% of nominal
Nominal Input Current Burden	0.5VA
Frequency	50Hz ±10%

## Accuracy

Voltage	0-5% of range maximum
Current	0-5% of nominal
Frequency	0-2% of mid-frequency
Power factor	1% of unity (0.01)
Active power (W)	±1% of range maximum
Reactive power (VAr)	±1% of range maximum
Apparent power (VA)	±1% of range maximum
Active energy (Wh)	Class 1 IEC 62053-21
Reactive energy (VARh)	±1% of range maximum
Total harmonic distortion	1% up to 31st harmonic
Response time to step input	1s, typical, to >99% of final reading, at 50 Hz.

## Auxiliary Supply

Two-way fixed connector with 2.5mm<sup>2</sup> stranded wire capacity. 85-275V AC 50Hz  $\pm 10\%$  or 120-380V DC  $\pm 20\%$ . Consumption <2W 10VA.

Operating range
87...275VAC $\pm 10\%$ / 120...380VDC $\pm 20\%$

## Interfaces for External Monitoring

Three interfaces are provided:

- RS485 communication channel that can be programmed for Modbus RTU protocol
- Relay output indicating real-time measured energy (configurable)
- Pulse output 3200IMP/kWh (not configurable)

The Modbus configuration (baud rate etc.) and the pulse relay output assignments (kW/kVAh, import/export etc.) are configured through the set-up screens.

## Pulse Output

Opto-coupler with potential free SPST-NO Contact (Contact rating - Voltage: 5-27V DC, Current: Imin 2mA and Imax 27mA DC). The pulse output can be set to generate pulses to represent kWh or kVAh.

Rate can be set to generate 1 pulse per:

0.01 = 10 Wh/VArh  
0.1 = 100 Wh/VArh  
1 = 1 kWh/kVAh  
10 = 10 kWh/kVAh  
100 = 100 kWh/kVAh

Pulse width 200/100/60 ms.

## RS485 Output for Modbus RTU

For Modbus RTU, the following RS485 communication parameters can be configured from the set-up menu:

**Baud Bate:** 2400, 4800, 9600, 19200, 38400

**Parity:** None (default) / Odd / Even

**Stop Bits:** 1 or 2

**RS485 Network Address:** 3 Digit Number - 001 to 247

**Modbus™ Word order** Hi/Lo byte order is set automatically to normal or reverse. It cannot be configured from the set-up menu.

## Reference Conditions of Influence Quantities

Influence Quantities are variables that affect measurement errors to a minor degree. Accuracy is verified under nominal value (within the specified tolerance) of these conditions.

Ambient temperature	23°C $\pm 1^\circ\text{C}$
Input waveform	50 or 60Hz $\pm 2\%$
Input waveform	Sinusoidal (distortion factor < 0.005)
Auxiliary supply voltage	Nominal $\pm 1\%$
Auxiliary supply frequency	Nominal $\pm 1\%$
Auxiliary supply waveform (if AC)	Sinusoidal (distortion factor < 0.05)
Magnetic field of external origin	Terrestrial flux

## Environment

Operating temperature	-25°C to +55°C*
Storage temperature	-40°C to +70°C*
Relative humidity	0 to 95%, non-condensing
Altitude	Up to 3000m
Warm up time	1 minute
Vibration	10Hz to 50Hz, IEC 60068-2-6, 2g
Shock	30g in 3 planes

\*Maximum operating and storage temperatures are in the context of typical daily and seasonal variation.

## Mechanics

DIN rail dimensions	72 x 94.5 mm (WxH) per DIN 43880
Mounting	DIN rail (DIN 43880)
Sealing	IP51 indoor
Material	Self-extinguishing UL 94 V-0

## Dimensions

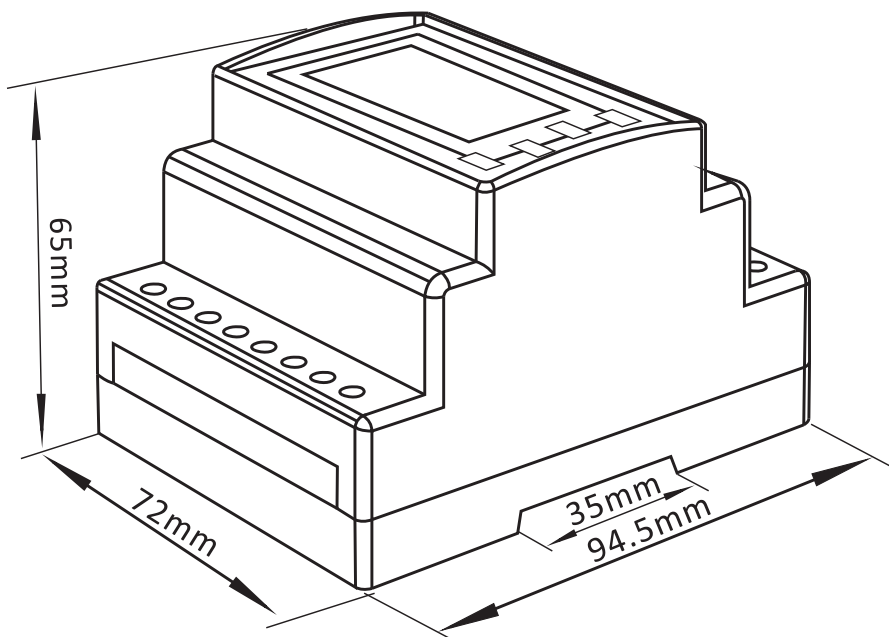

## Installation

