

PROPOSED GROUND FLOOR PLAN

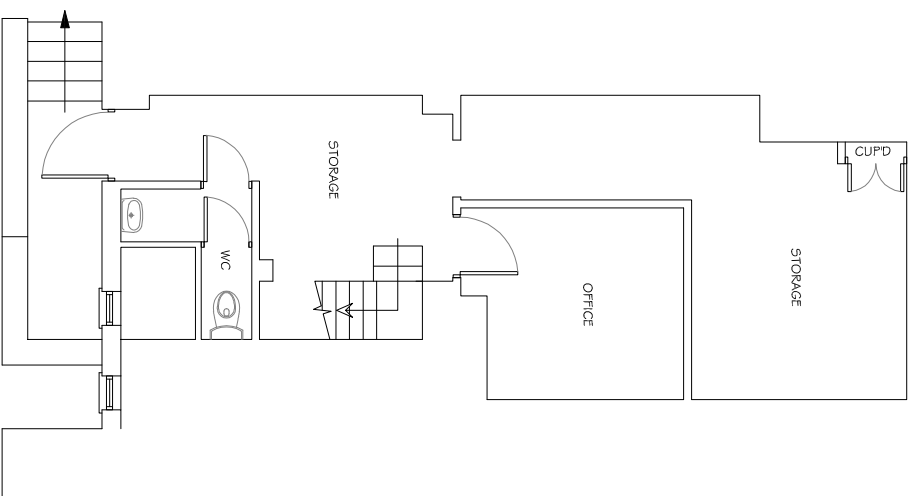

PROPOSED BASEMENT FLOOR PLAN (NO CHANGE)

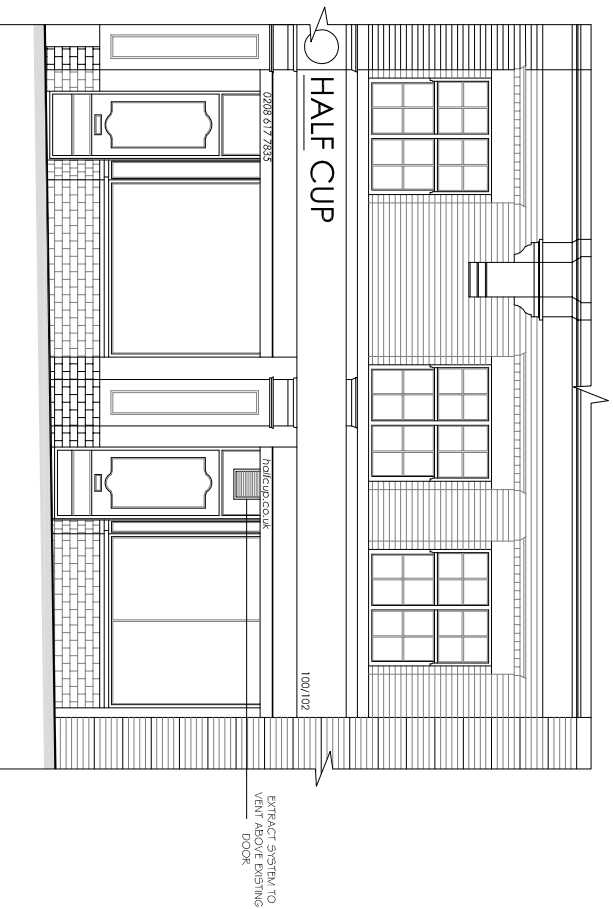

PROPOSED FRONT ELEVATION

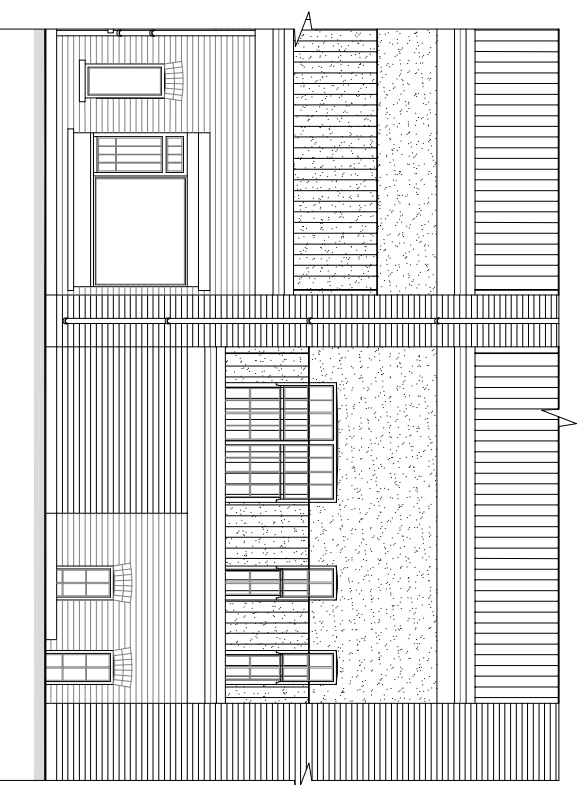

PROPOSED REAR ELEVATION (NO CHANGE)



INDICATIVE
BLOCK
PLAN
1:500

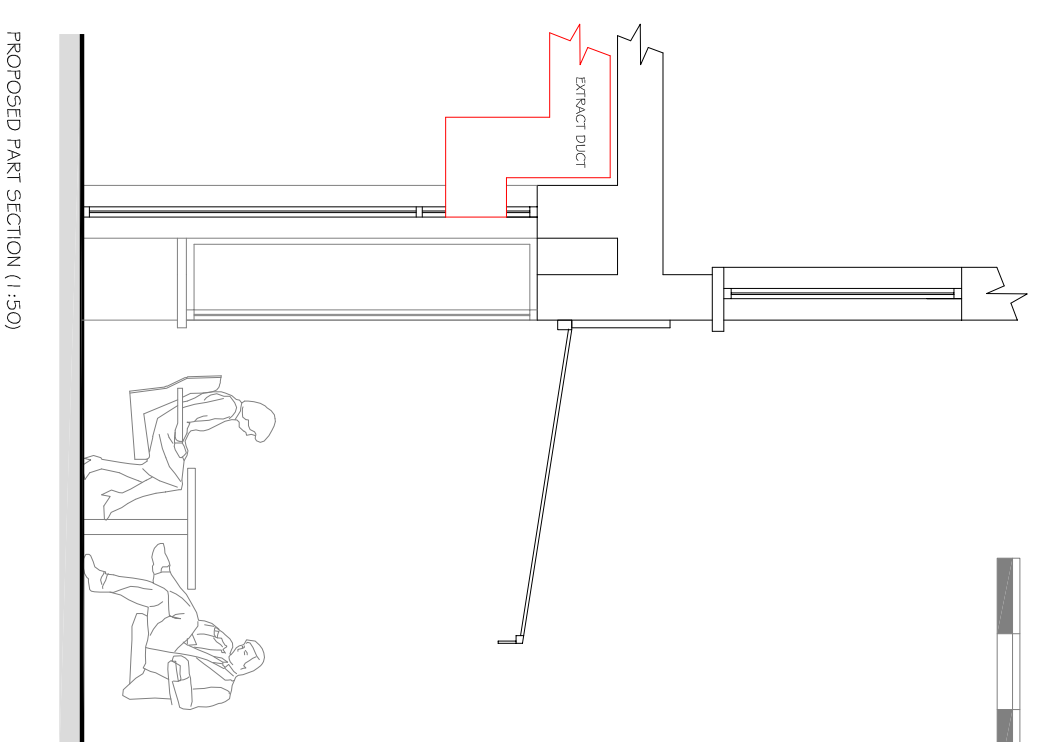

PROPOSED PART SECTION (1:50)

REVISION NOTES:

REV:	DATE:	NOTES:
A	21/06/2018	ALTERATIONS TO TITLE BLOCK

DRAWING TITLE:
PROPOSED FLOOR PLANS & ELEVATIONS
INC BLOCK PLAN & SECTION

CLIENT:
KUMARI MORAK

PROJECT NO:
926

PROJECT ADDRESS:
HALF CUP
100 - 102 JUDD STREET
LONDON
WH1H 9NT

DATE:
JAN 2018

SCALE:
1:50 1:100 1:500

DRAWING NUMBER:
02A

CHANGE THE USE
2 WEST STREET
EWELL
SURREY
KT17 1UU

change
theuse.co.uk

From The Planning Gurus

t: 0208 393 2675
m: info@changeuse.co.uk
w: www.changeuse.co.uk