

Client **Mr Johathan Kemp**  
 Job **Traditional Box Sash Window - Slimlite type Acoustic glass - Viewed from outside**  
 Ref **WC2H 9JN Kemp 1947**

	<p><b>Sliding Sash</b></p> <p>Living-room-front - Traditional Box sash window - Sash frame narrow profile sections - No sash horns                  Box frame - Ovolo Section - DGU                  Traditional Box Frame</p> <p>Accoya                  Slim Light Double Glazed Units 6.8mm - 4mm black spacer - 4mm</p>	<p><b>KP1</b></p> <p><b>x1</b></p>
	<p><b>Sliding Sash</b></p> <p>Bedroom-front - Traditional Box sash window - Sash frame special narrow profile sections - No sash horns                  Box frame - Ovolo Section - DGU                  Traditional Box Frame</p> <p>Accoya                  Slim Light Double Glazed Units 6.8mm - 4mm black spacer - 4mm</p>	<p><b>KP2</b></p> <p><b>x1</b></p>
	<p><b>Sliding Sash</b></p> <p>Bedroom-rear - Traditional Box sash window - Sash frame special narrow profile sections - No sash horns                  Box frame - Ovolo Section - DGU                  Traditional Box Frame</p> <p>Accoya                  Slim Light Double Glazed Units 6.8mm - 4mm black spacer - 4mm</p>	<p><b>KP3</b></p> <p><b>x1</b></p>
	<p><b>Sliding Sash</b></p> <p>Kitchen-rear - Traditional Box sash window - Top sash 1/3rd height top give same layout glass panes as on current window - Sash frame special narrow profile sections - No sash horns                  Box frame - Ovolo Section - DGU                  Traditional Box Frame</p> <p>Accoya                  Slim Light Double Glazed Units 6.8mm - 4mm black spacer - 4mm</p>	<p><b>KP4</b></p> <p><b>x1</b></p>
	<p><b>Sliding Sash</b></p> <p>Bathroom-rear - Traditional Box sash window - Sash frame special narrow profile sections - No sash horns - Clear glass                  Box frame - Ovolo Section - DGU                  Traditional Box Frame</p> <p>Accoya                  Slim Light Double Glazed Units 6.8mm - 4mm black spacer - 4mm</p>	<p><b>KP5</b></p> <p><b>x1</b></p>







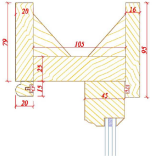

--	--	--	--

Job number <b>1947</b>	Job reference <b>WC2H 9JN Kemp 1947</b>	14:57 12-05-18	1 of 11
---------------------------	--	----------------	---------

Client **Mr Johathan Kemp**

Job **Traditional Box Sash Window - Slimlite type Acoustic glass - Viewed from outside**

Ref **WC2H 9JN Kemp 1947**

	<p><b>Frame/ Door Sections</b></p> <p>Box Sash Frame Section 141mm Deep with Slimlite type glass Sashes have Lambs Tongue moulding internally Sashes 40mm wide and 45mm deep with 9.5mm rebate for glass</p>	<p><b>SECTION</b></p> <p><b>x1</b></p>
	<p><b>Glass</b></p> <p>Clear glass - High performance double glazed slimlite type unit with acoustic glass 14.8mm unit consisting of 4 mm Planitherm - 4 mm black spacer with argon fill – 6.8 mm stadip silence laminated</p>	<p><b>GLASS</b></p> <p><b>x1</b></p>
	<p><b>Conservation Bars</b></p> <p>20mm Wide Glazing Bars - Externally angled 8mm x 8mm putty profile timber beads each side - Internally has Lambs Tongue Moulding</p>	<p><b>BARS</b></p> <p><b>x1</b></p>
	<p><b>Paint Colours</b></p> <p>Standard Semi-Gloss White Inside and Out</p>	<p><b>FINISH</b></p> <p><b>x1</b></p>
	<p><b>Window Hardware Polished Brass</b></p> <p>Pulleys Polished Brass</p>	<p><b>PULLEYS</b></p> <p><b>x20</b></p>
	<p><b>Window Hardware Polished Brass</b></p> <p>Polished Brass Brighton Fastener Croft 1826</p>	<p><b>FURNITURE</b></p> <p><b>x5</b></p>
	<p><b>Window Hardware Polished Brass</b></p> <p>Polished Brass Sash Lifts Croft 2845, 2 per window</p>	<p><b>FURNITURE</b></p> <p><b>x10</b></p>
	<p><b>Window Hardware Polished Brass</b></p> <p>Polished Brass Stop Locks with locked and 100mm ventilation Postion - 1 each side on each opening window</p>	<p><b>FURNITURE</b></p> <p><b>x5</b></p>

Job number

**1947**

Job reference



**WC2H 9JN Kemp 1947**

14:57 12-05-18

**2 of 11**

## Customer Order Summary

Client **Mr Johathan Kemp**  
 Job **Traditional Box Sash Window - Slimlite type Acoustic glass - Viewed from outside**  
 Ref **WC2H 9JN Kemp 1947**

	<p><b>Internal Components</b>                  Architrave No 535 (94mm x 28mm) Internally to Sides and Head                  4 alternative profiles to choice from - Or additional option of Special architrave</p>	<p><b>ARCHITRAVE</b>  <b>x3</b></p>
	<p><b>Internal Components</b>                  Linings to sides and head internally</p>	<p><b>LININGS</b>  <b>x3</b></p>
	<p><b>Internal Components</b>                  Internal Sill Boards long round both ends</p>	<p><b>SILLBOARD</b>  <b>x1</b></p>

--	--	--

Client **Mr Johathan Kemp**

Job **Traditional Box Sash Window - Slimlite type Acoustic glass - Viewed from outside**

Ref **WC2H 9JN Kemp 1947**

### 1 X Sliding Sash - KP1 (Living-room-front)

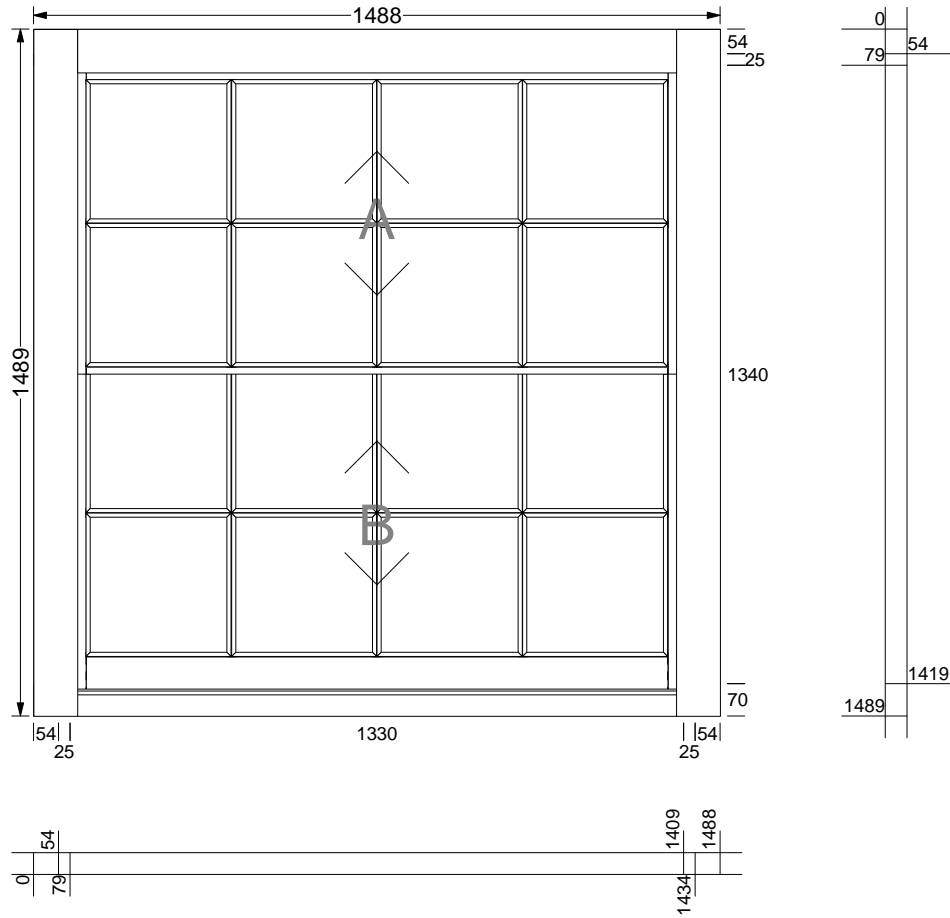

#### KP1 Top sliding sash

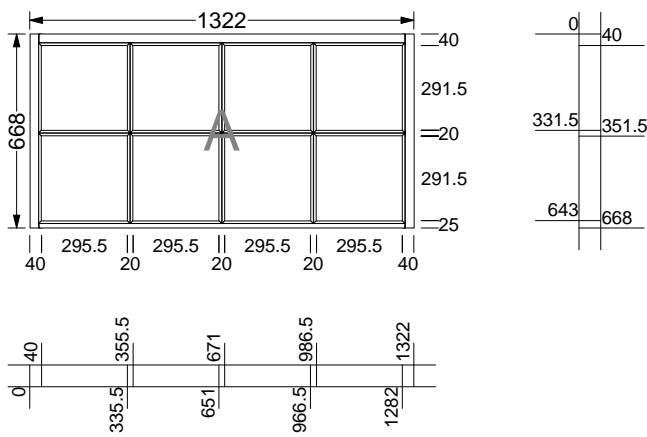

#### KP1 Bottom sliding sash

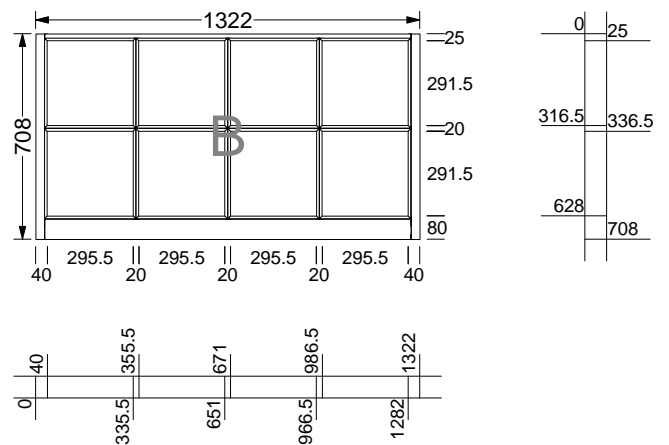

### 1 X Sliding Sash - KP2 (Bedroom-front)

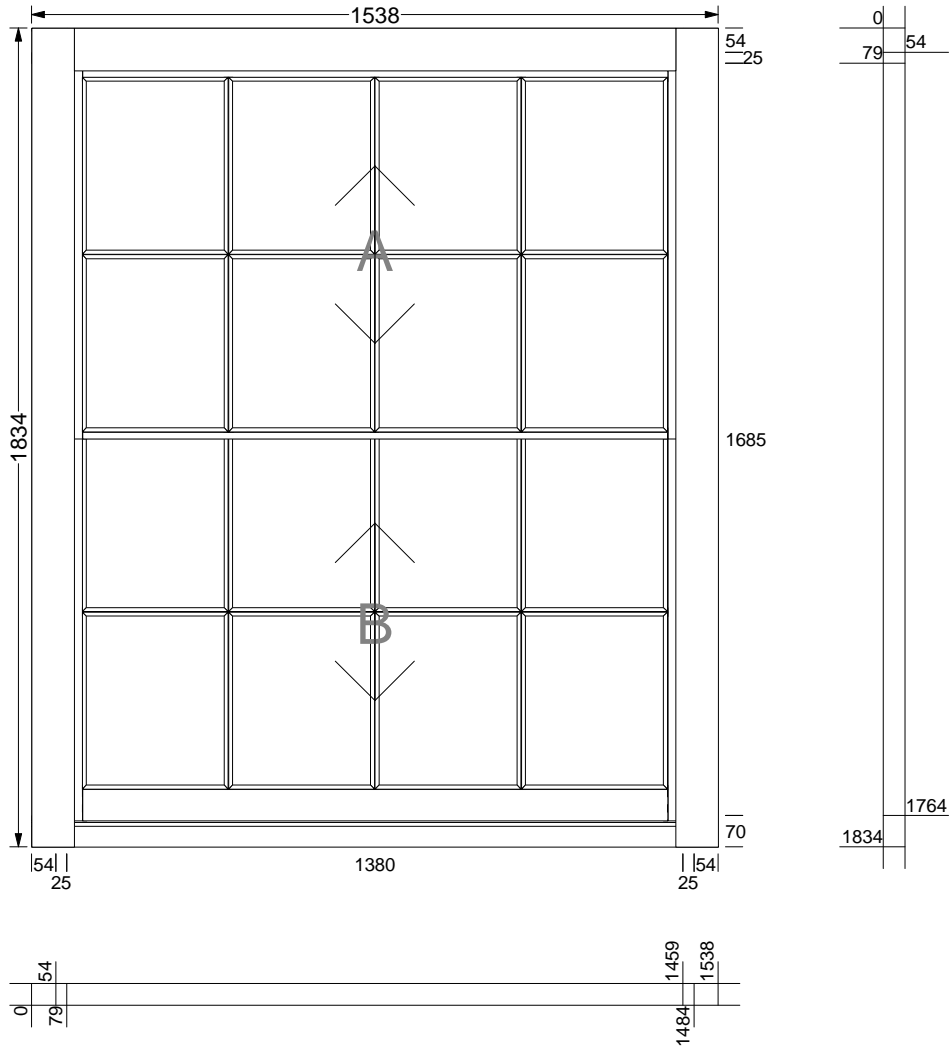

#### KP2 Top sliding sash

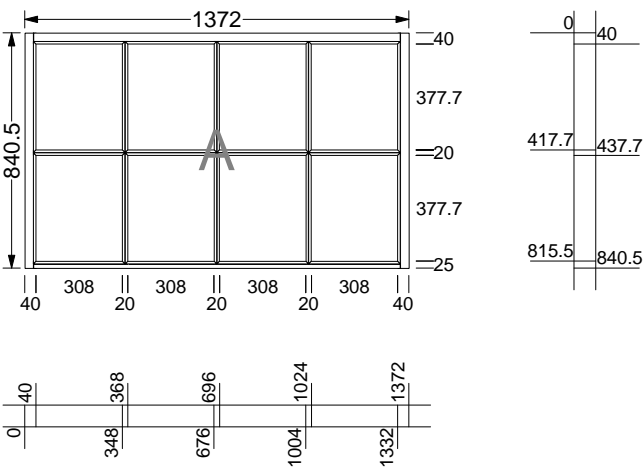

#### KP2 Bottom sliding sash

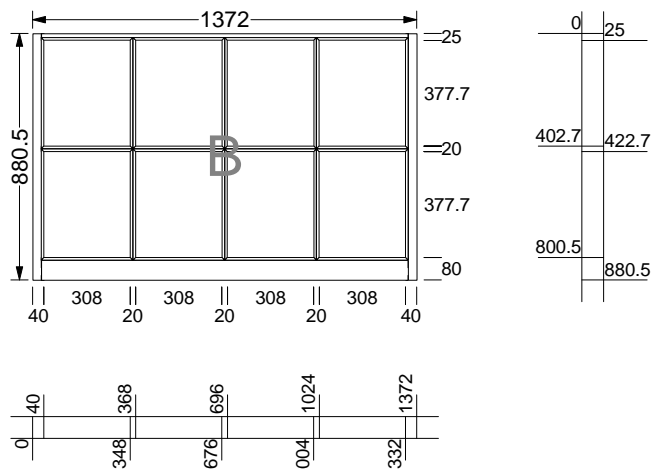

### 1 X Sliding Sash - KP3 (Bedroom-rear)

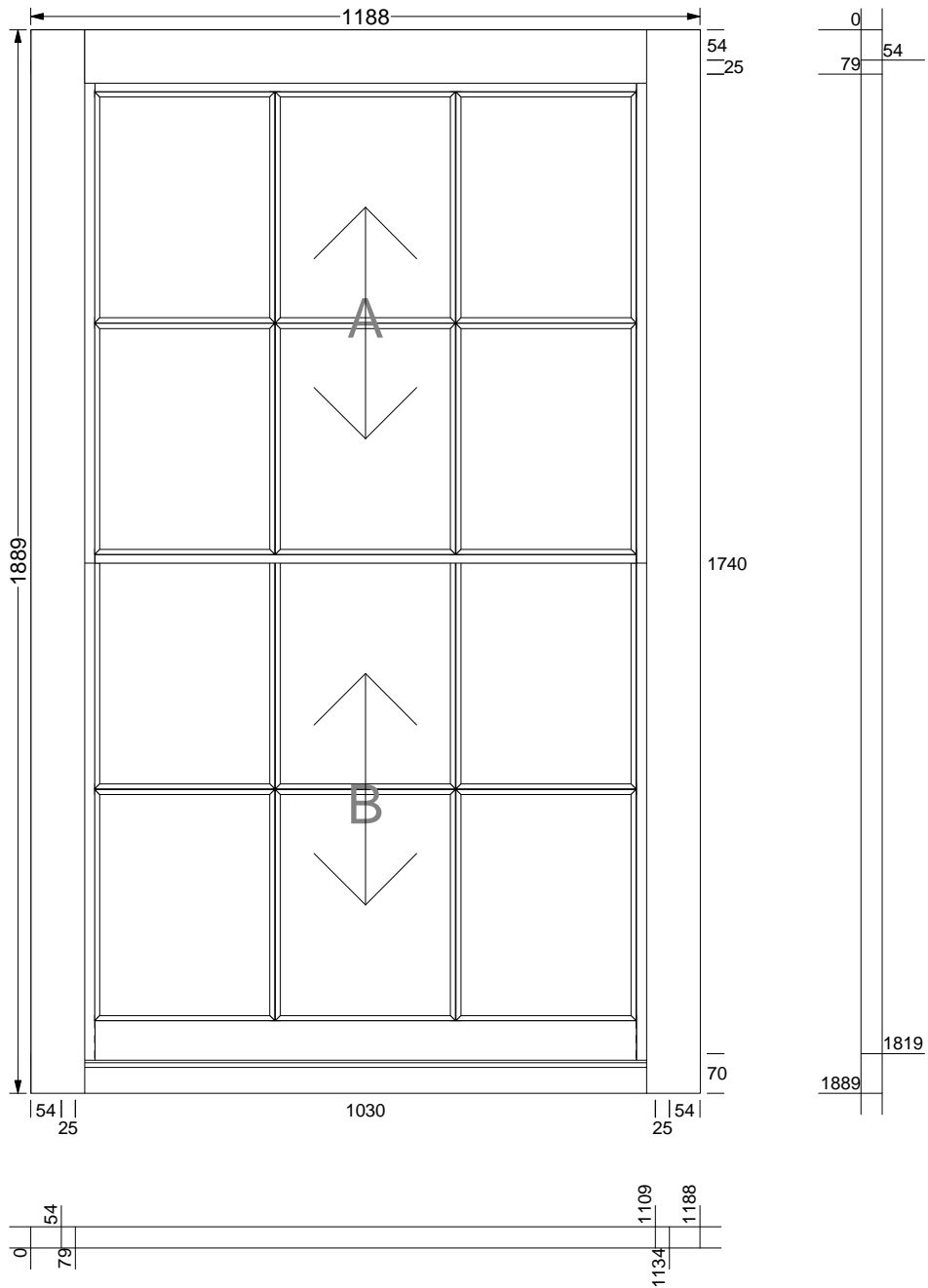

KP3  
Top sliding sash

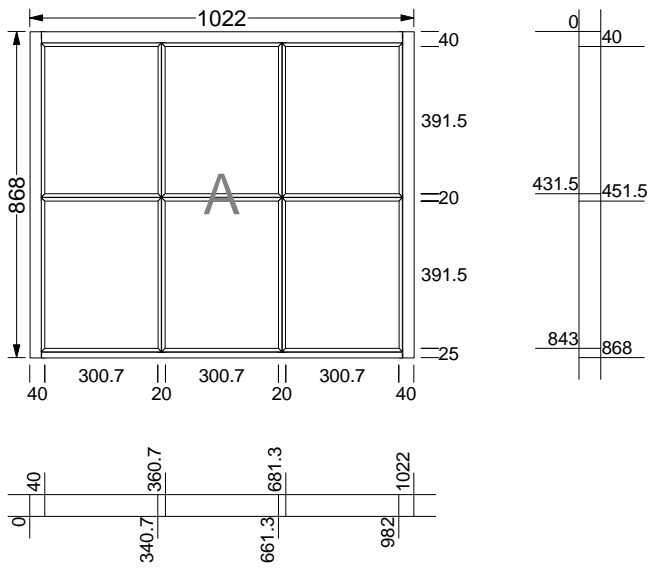

KP3  
Bottom sliding sash

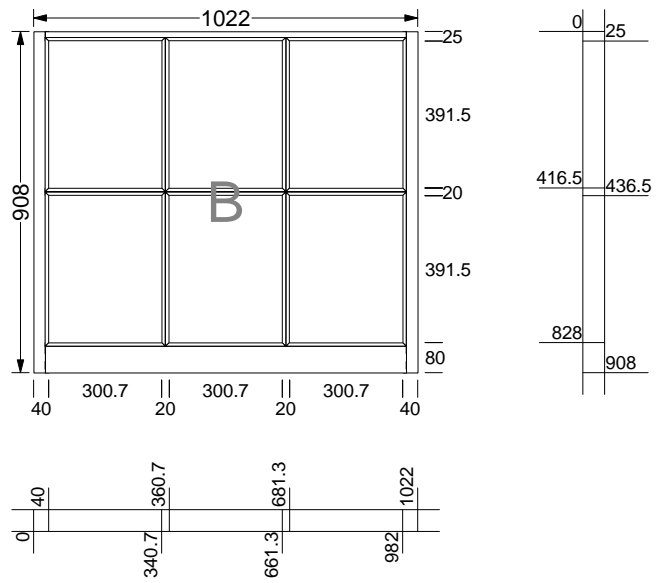

### 1 X Sliding Sash - KP4 (Kitchen-rear)

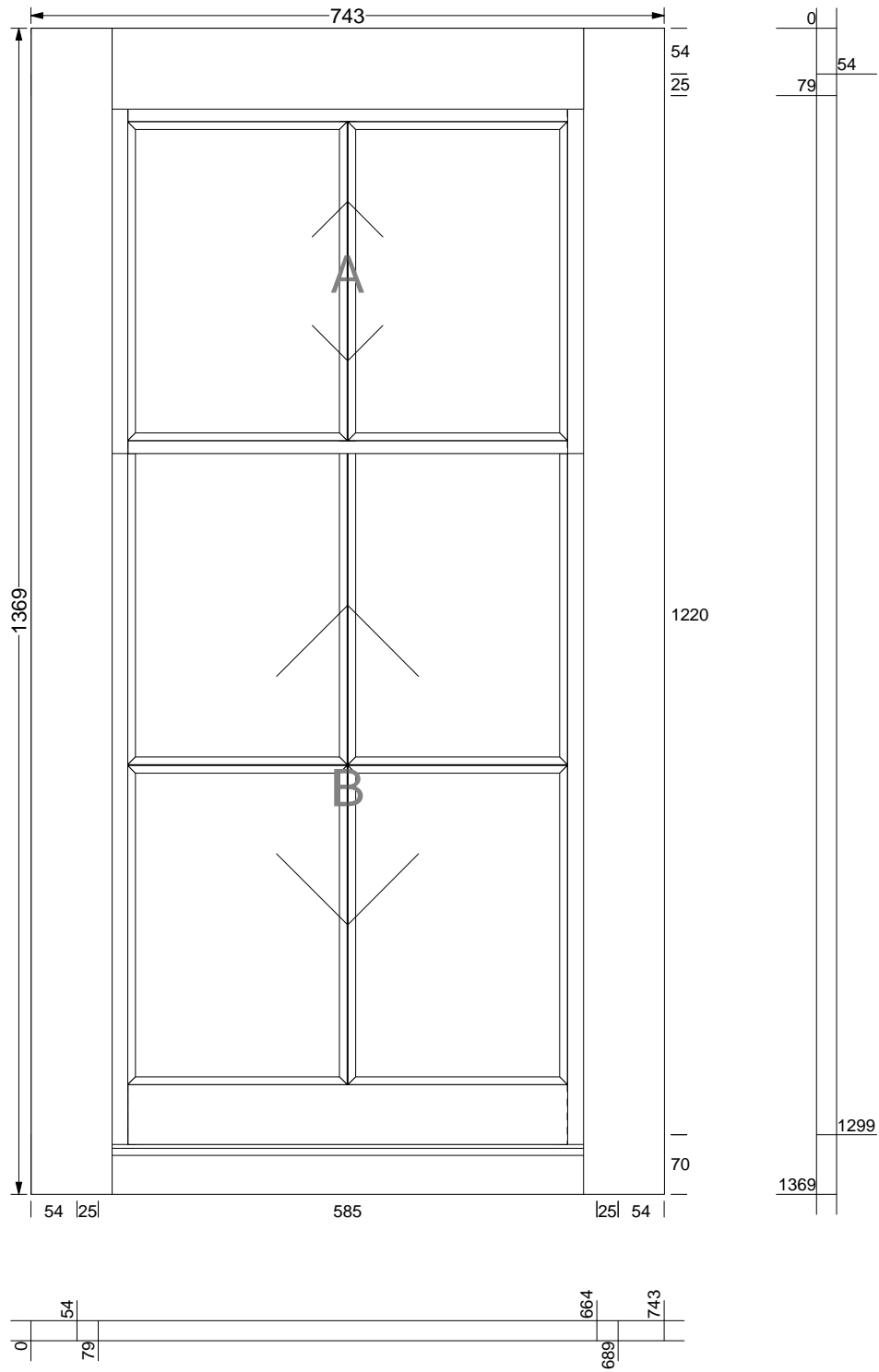



KP4  
Top sliding sash

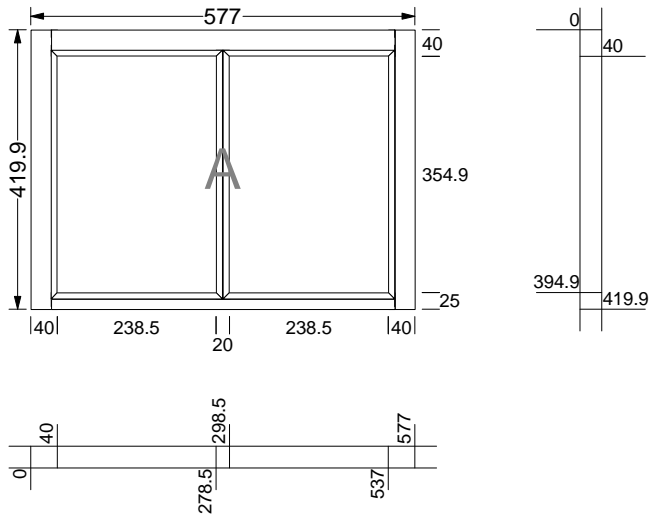

KP4  
Bottom sliding sash

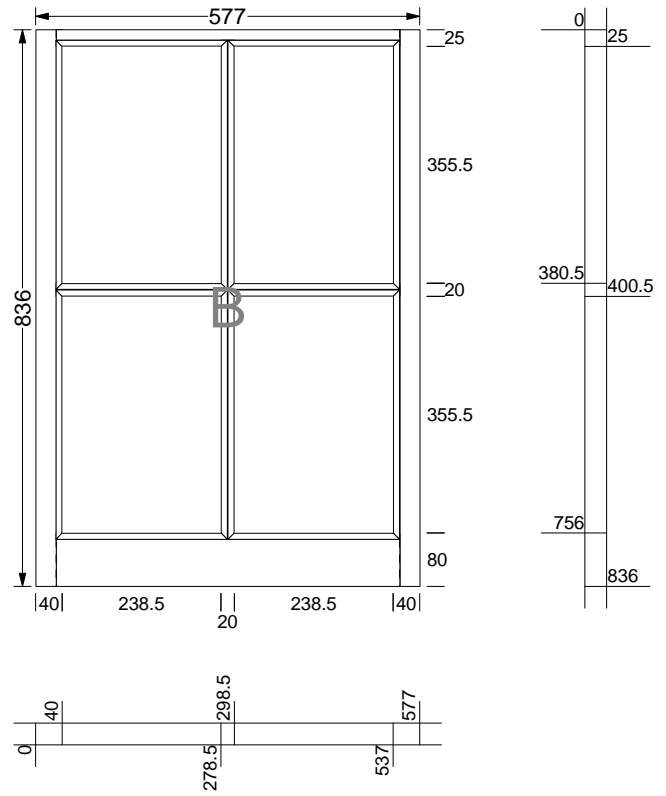

### 1 X Sliding Sash - KP5 (Bathroom-rear)

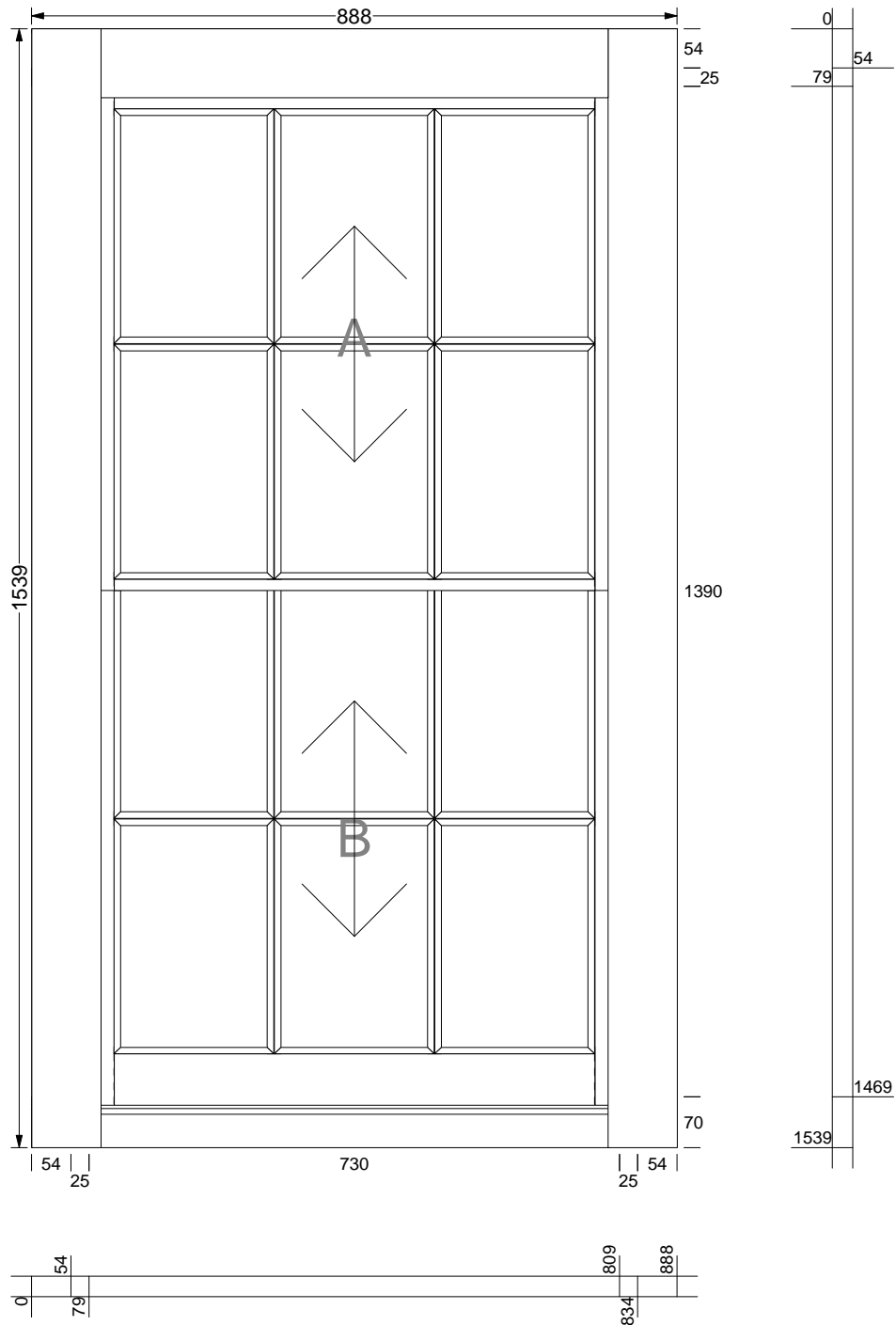

KP5  
Top sliding sash

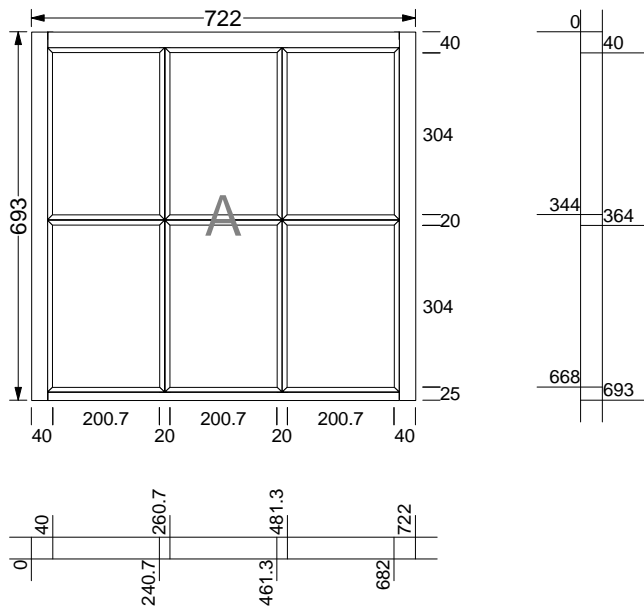

KP5  
Bottom sliding sash

