

USE FIGURED DIMENSIONS ONLY.  
ALL DIMENSIONS MUST BE CHECKED ON SITE & ANY INCONSISTENCIES  
MUST BE REPORTED BACK TO THE ARCHITECT.

THIS DRAWING AND ANY DESIGNS INDICATED THEREON ARE THE  
COPYRIGHT OF THE ARCHITECT. ALL RIGHTS ARE RESERVED. NO PART  
OF THIS WORK MAY BE REPRODUCED WITHOUT PRIOR PERMISSION IN  
WRITING FROM THE ARCHITECT.

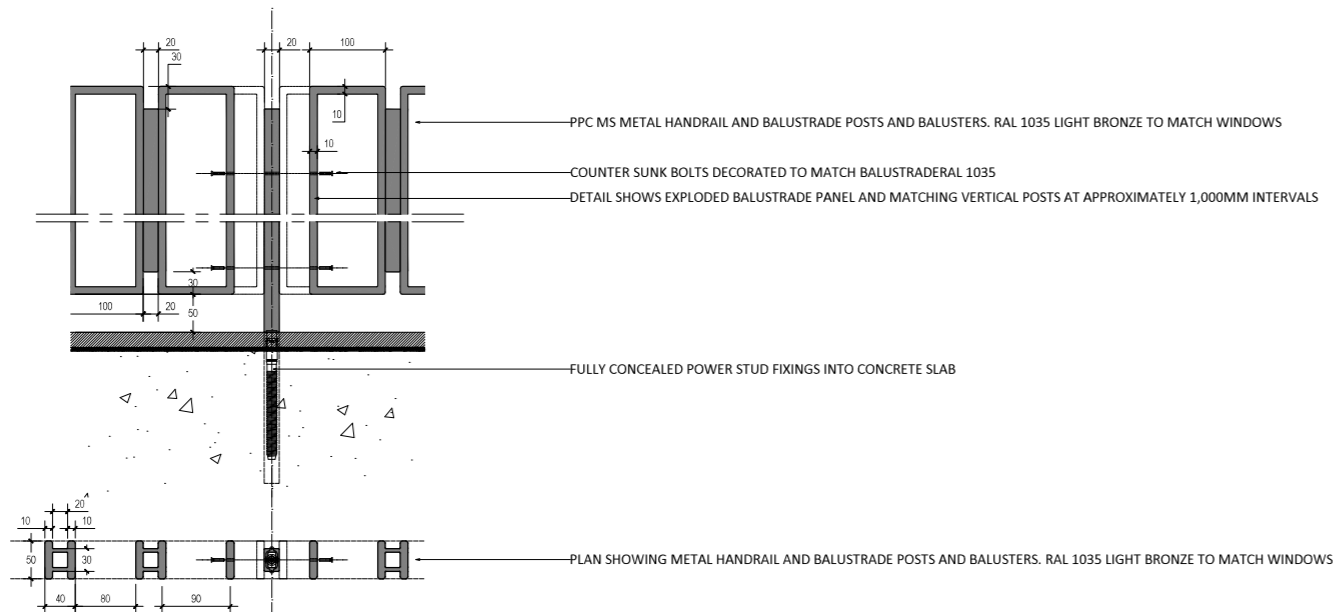

**1** PROPOSED SITE PLAN  
1 : 100



**DETAIL PLAN AND ELEVATION** 10  
SCALE: 1:5

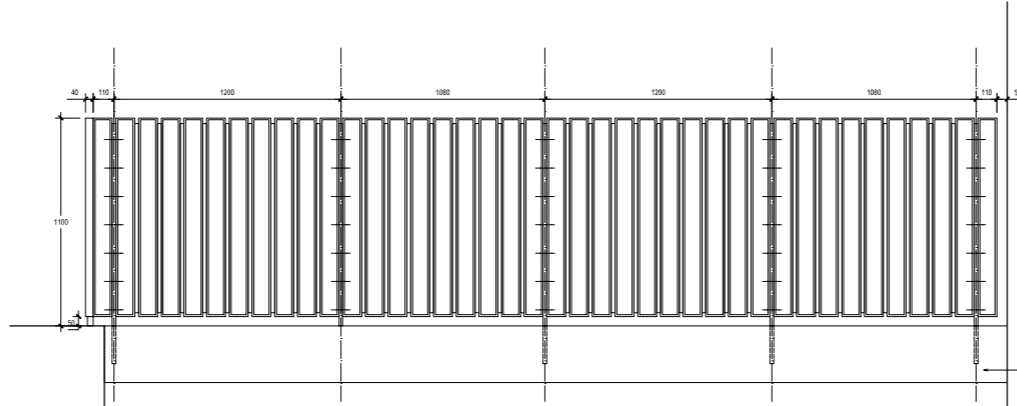
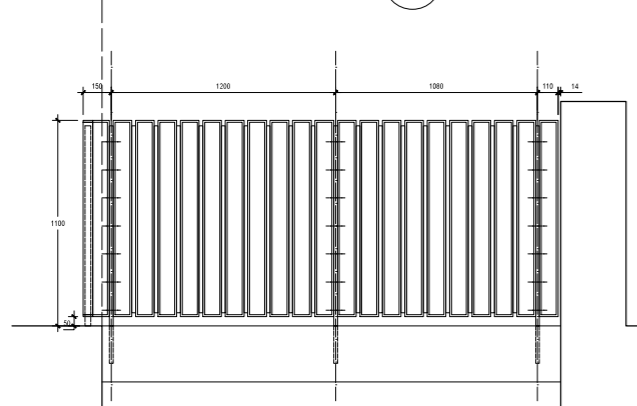
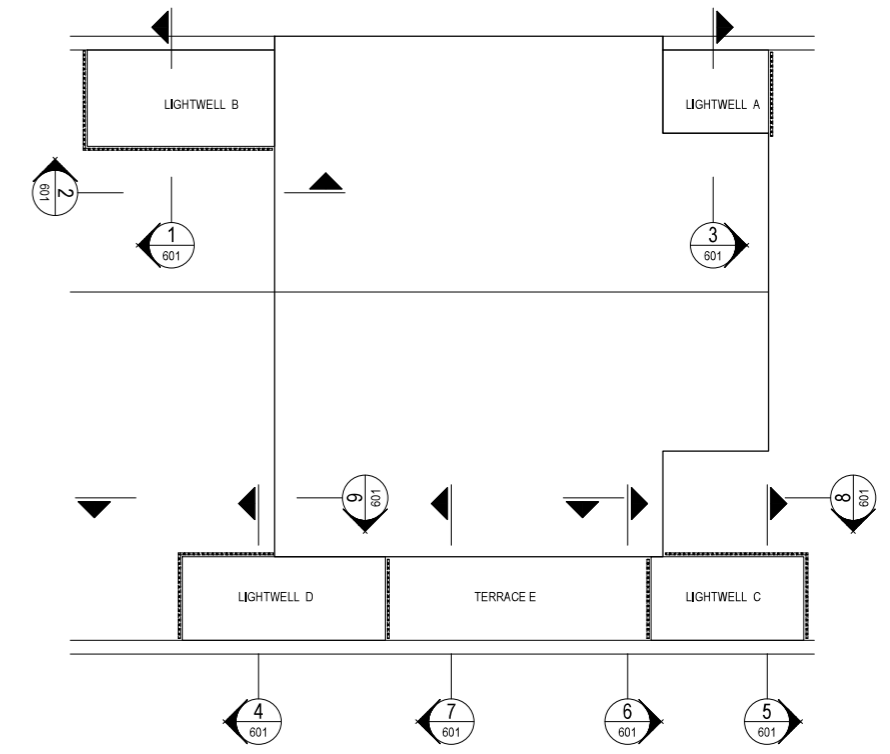

DOTTED LINES INDICATE PPC MS METAL POSTS AT APPROXIMATELY 1,000MM INTERVALS

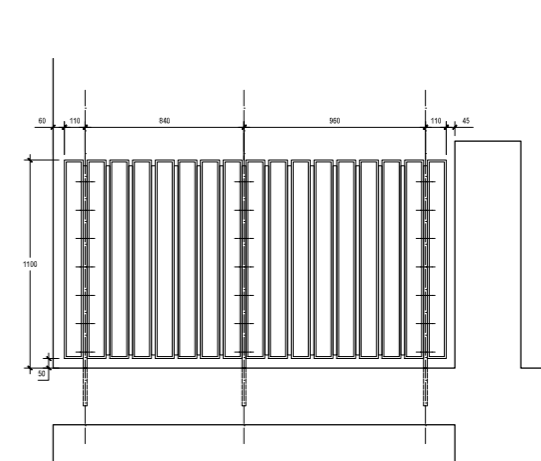
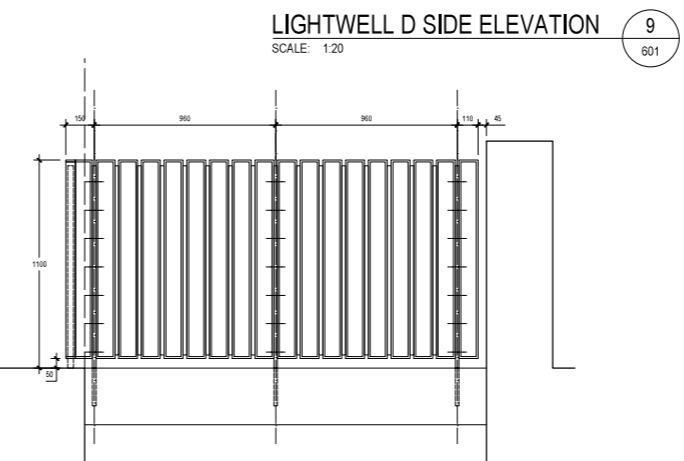
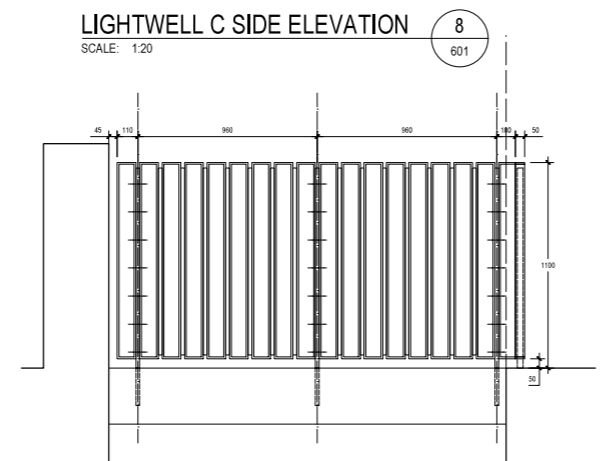
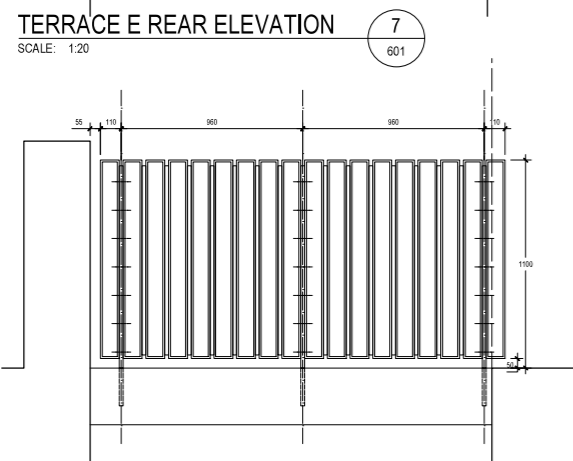
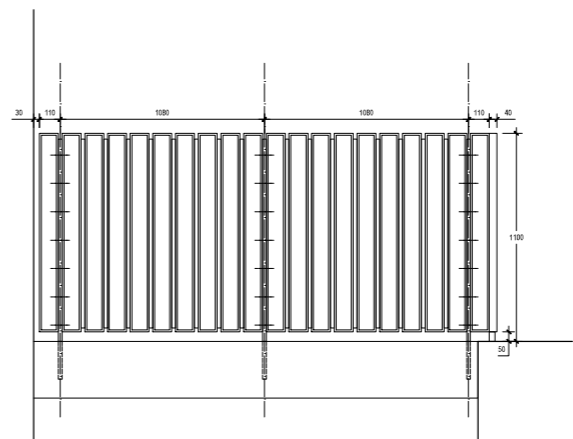
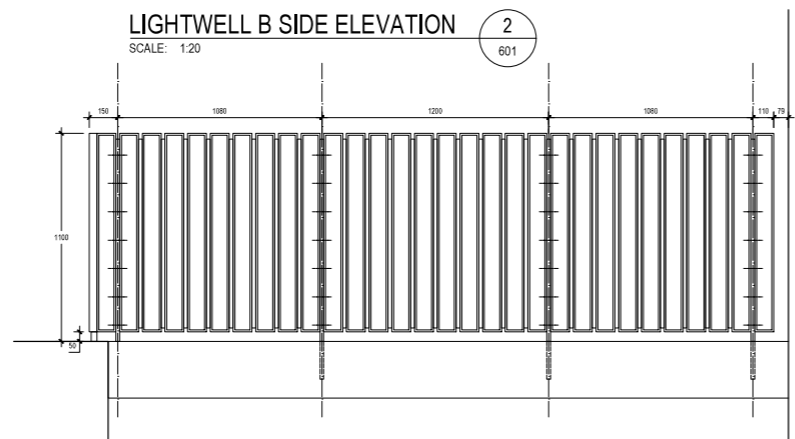
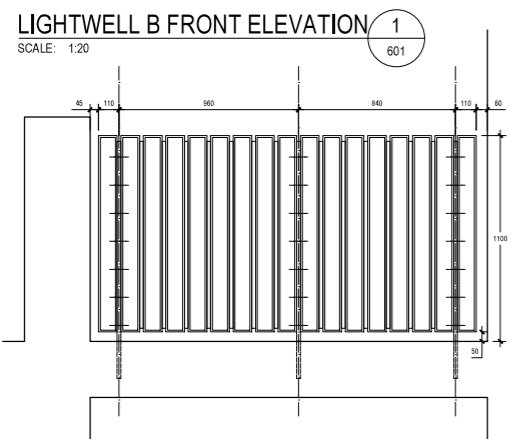

**LIGHTWELL A FRONT ELEVATION** 3  
SCALE: 1:20

**LIGHTWELL D FRONT ELEVATION** 4  
SCALE: 1:20

**LIGHTWELL C FRONT ELEVATION** 5  
SCALE: 1:20

**TERRACE E FRONT ELEVATION** 6  
SCALE: 1:20