

Note:  
Refer to Internal door schedule for Acoustic rating requirements

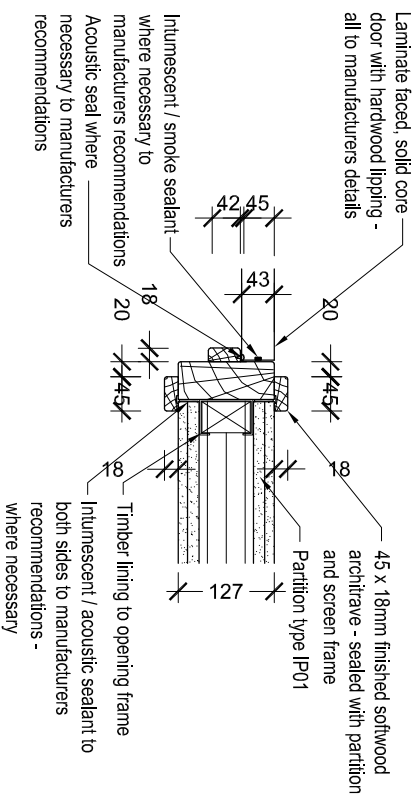

**Plan Detail DD01**  
Typical Internal door jamb detail -  
(shown in Partition Type IP01)

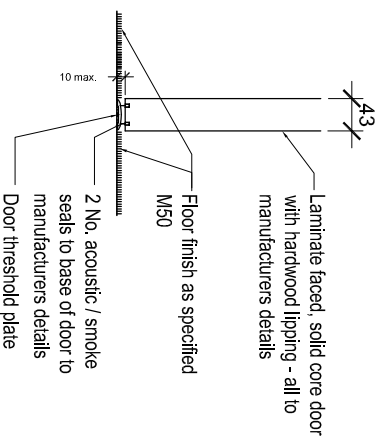

**Section Detail DD02**  
Typical Internal door threshold detail -  
(shown in Partition Type IP01)

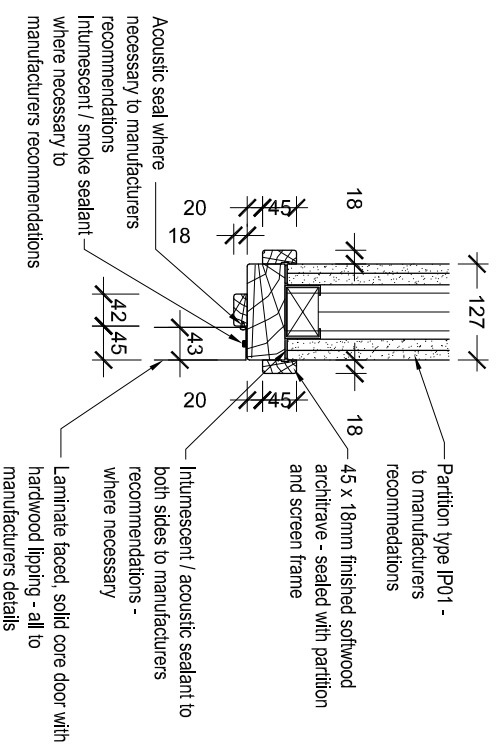

**Section Detail DD03**  
Typical Internal door head detail -  
(shown in Partition Type IP01)

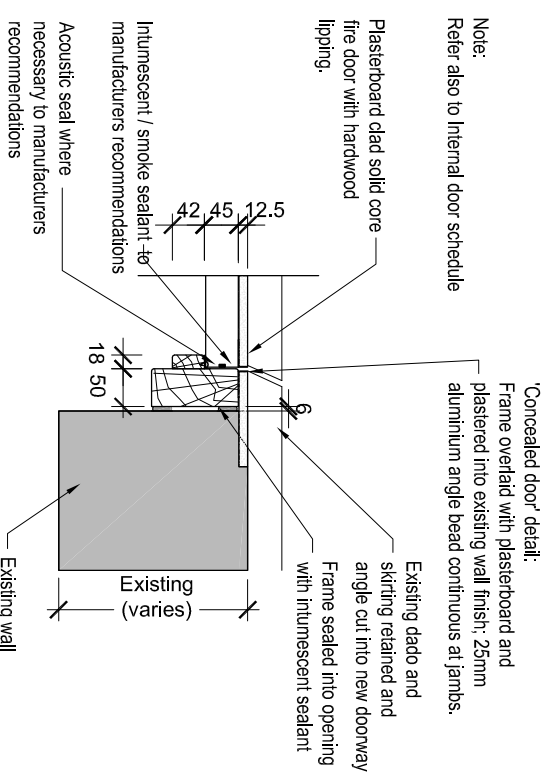

**Plan Detail DD04**  
Type 5 Concealed Door:  
Internal door jamb detail set into existing walls

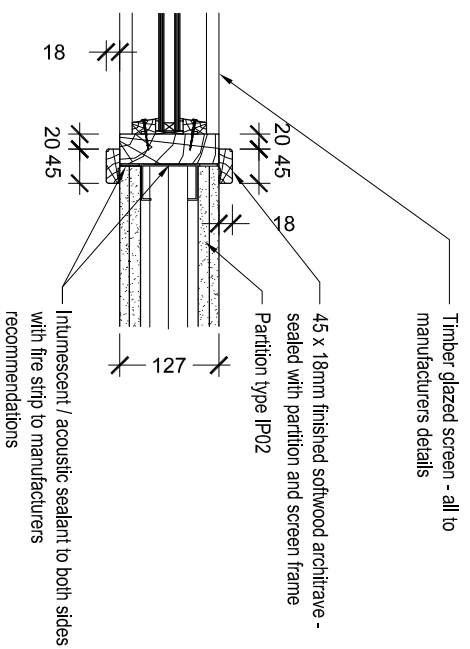

**Plan Detail GS01**  
Timber Glazed screen jamb detail -  
Partition Type IP01

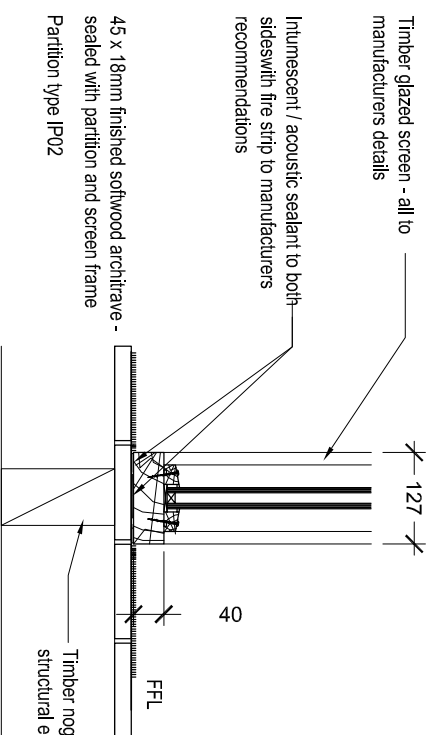

**Section Detail GS02**  
Timber Glazed screen floor detail -  
Partition Type IP01

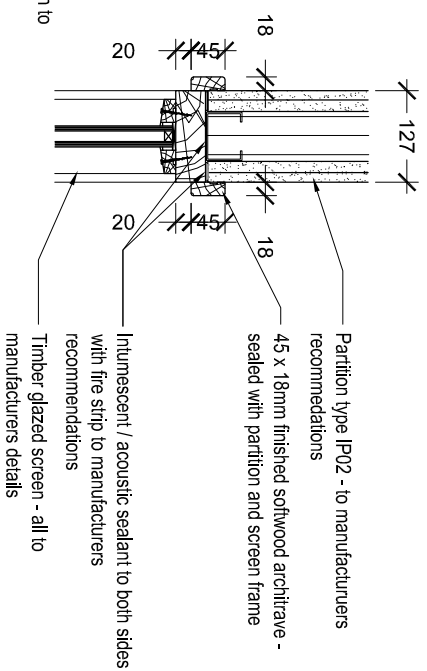

**Section Detail GS03**  
Timber Glazed screen head detail -  
Partition Type IP01

REV	DATE	REVISION/NOTE	BY	CHECK

