

PROJECT: Window and French door replacement
DOCUMENT: Drawings for existing and proposed windows
DATE: 8 November 2017

To accompany the application for listed building consent for the replacement of windows and French doors to be done at Flat 5, 10 Lyndhurst Gardens, NW3 5NR.

NOTE: all the proposed windows and French doors are like for like vis-à-vis the existing ones, as shown in the file "03-10LGF5-Pictures current windows".

Window replacement

Window 1 (Kitchen)

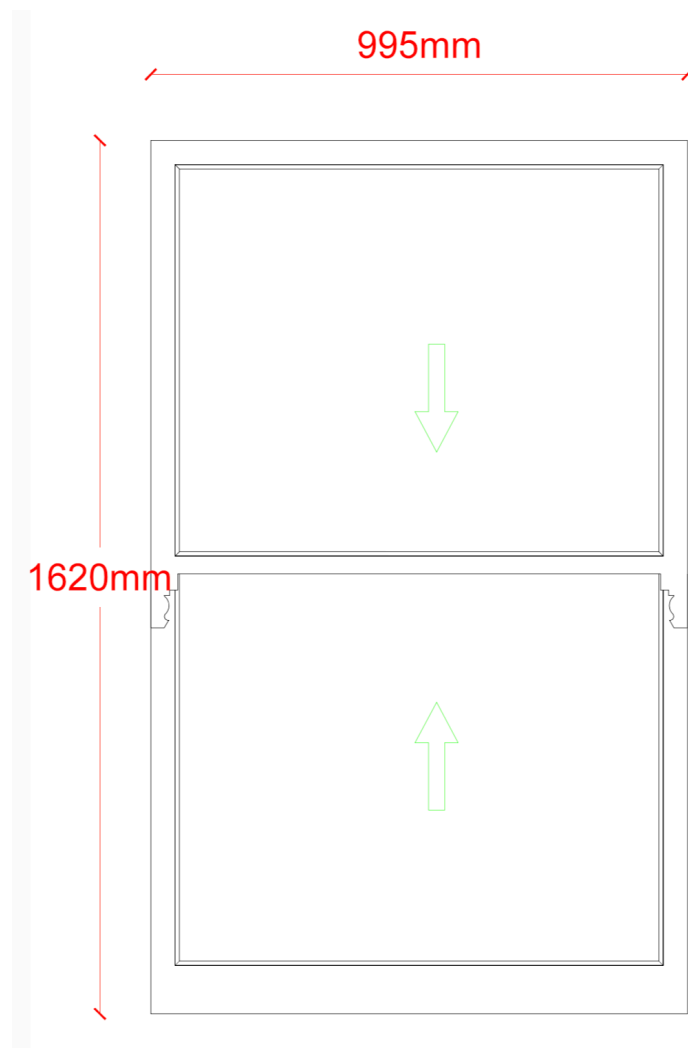

Window 2 (Kitchen)

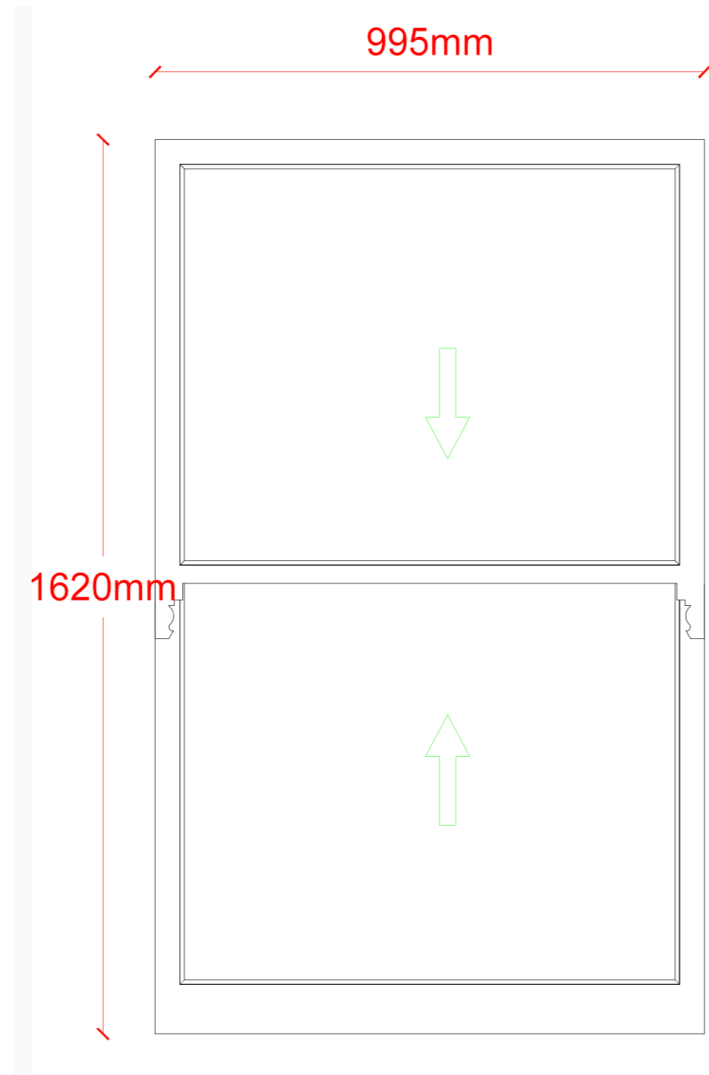

Window 3 (Kitchen)

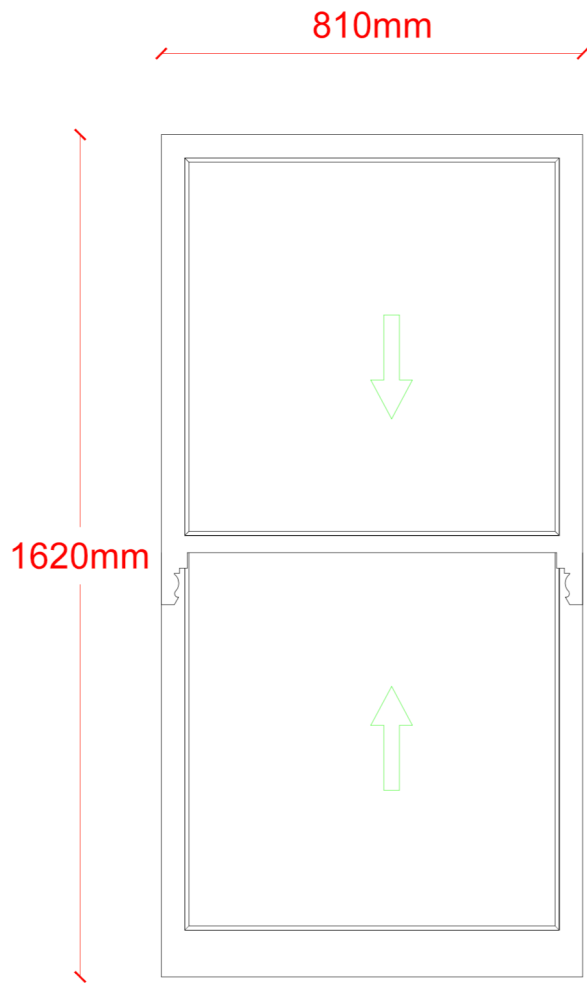

Window 4 (guest bedroom)

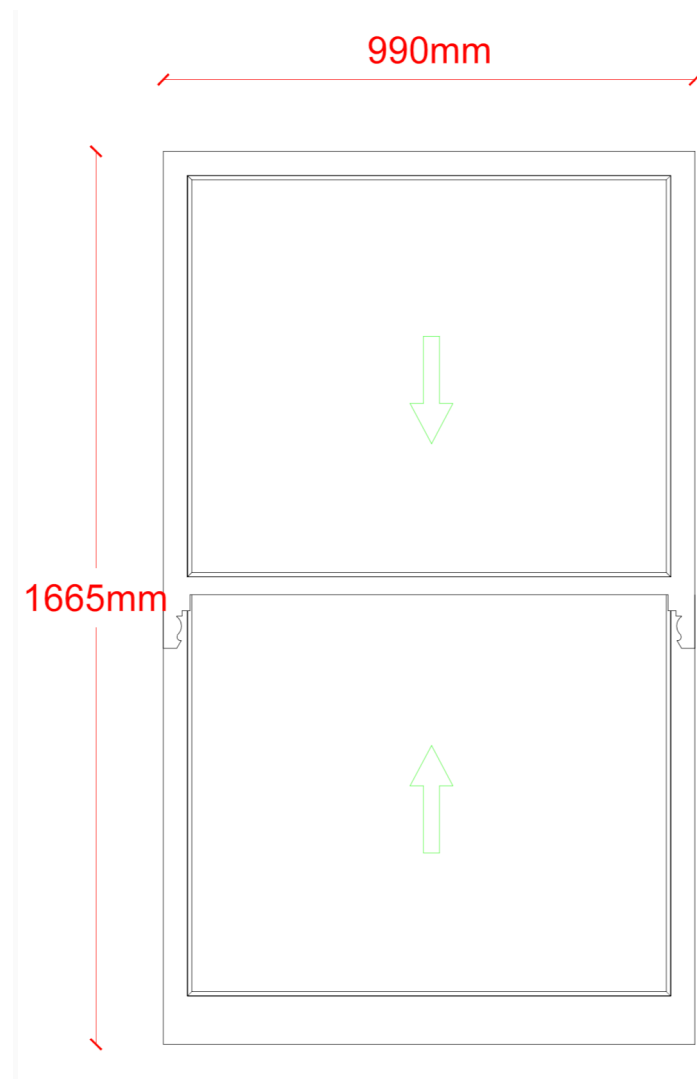

Windows 5-10 (Bay window living room)

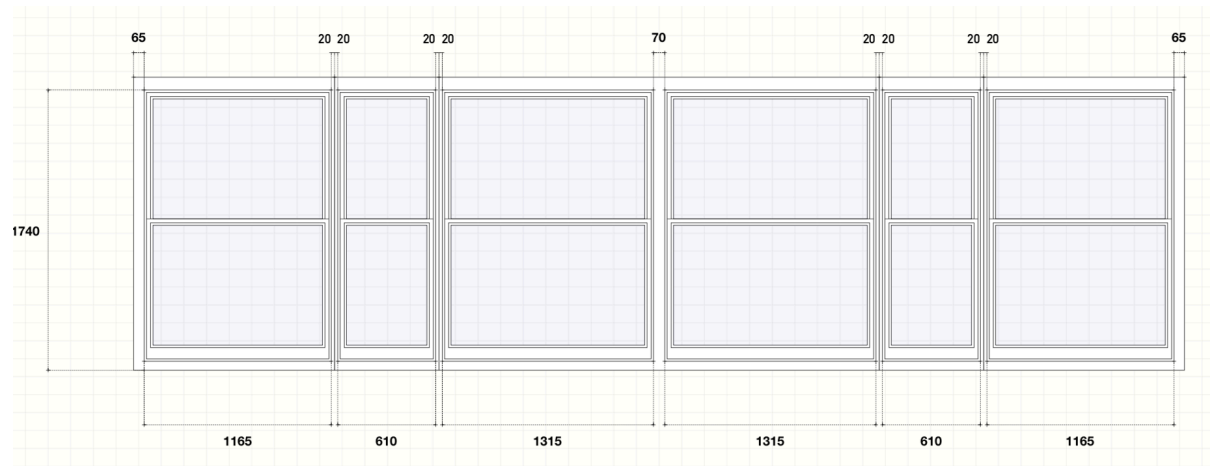

Window 11 (Child bedroom)

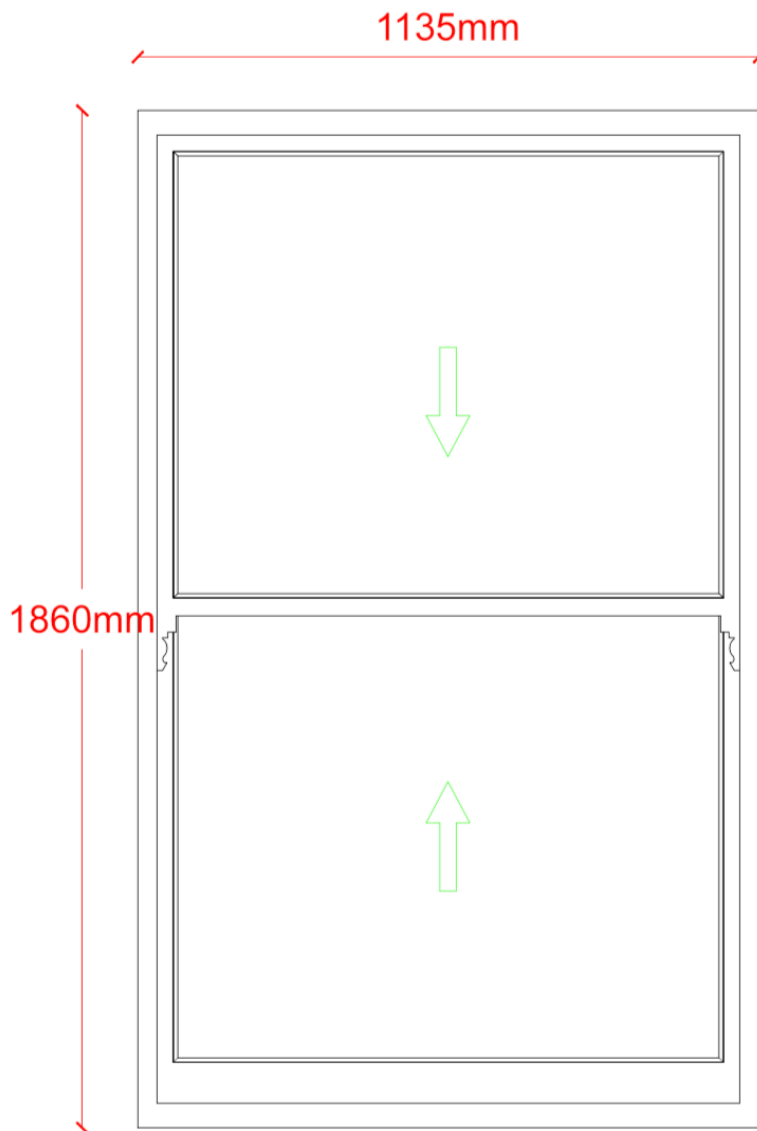

French doors & windows 12-15 (Master bedroom)

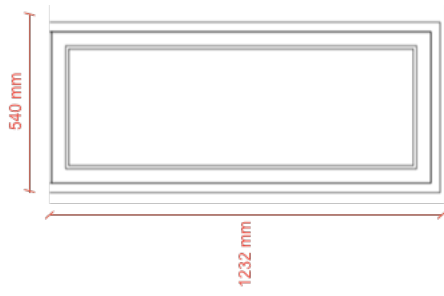

Supporting technical drawings

