

EXTERNAL
W
01

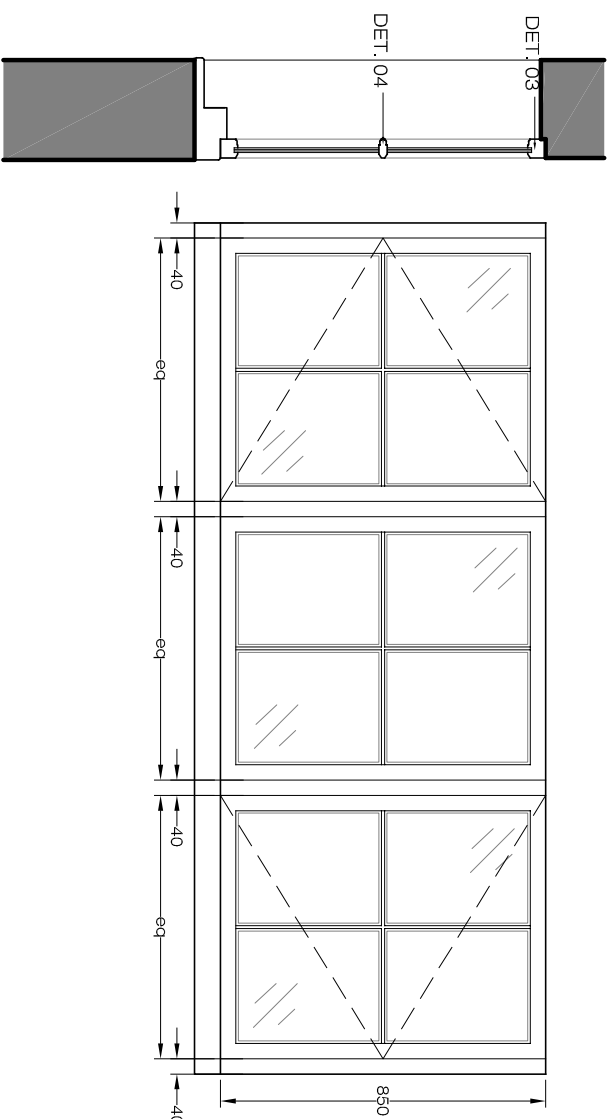

Window Code	W-01
Location	Rear - Ground Floor Kitchen
Dimensions (mm)	2225 x 850mm (WxH)
Glazing	Double glazing
Description	Timber window (Conservation Area Style) to match like-for-like the design of the existing windows.
Accessories	As existing

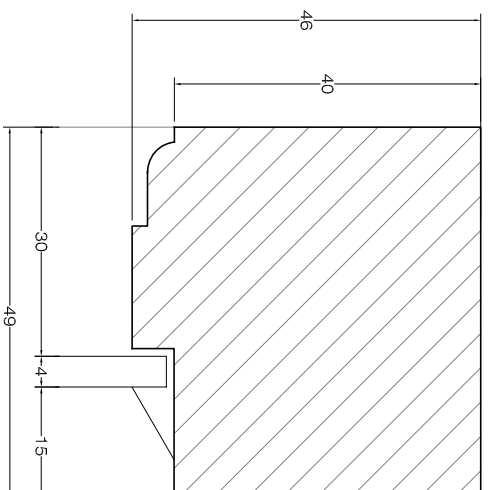
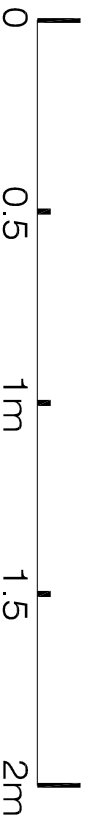

EXISTING WINDOW
Detail 01 - Frame
SCALE 1/1@A3

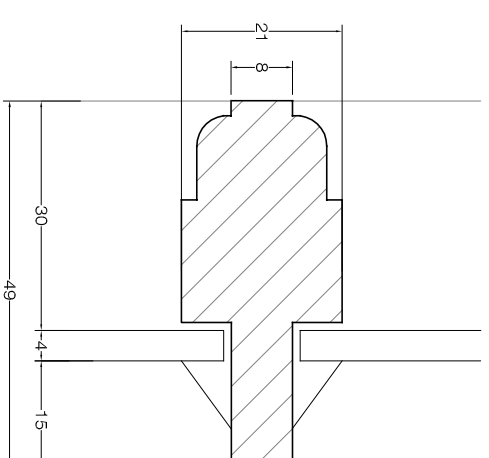

EXISTING WINDOW
Detail 02 - Glazing Bar
SCALE 1/1@A3

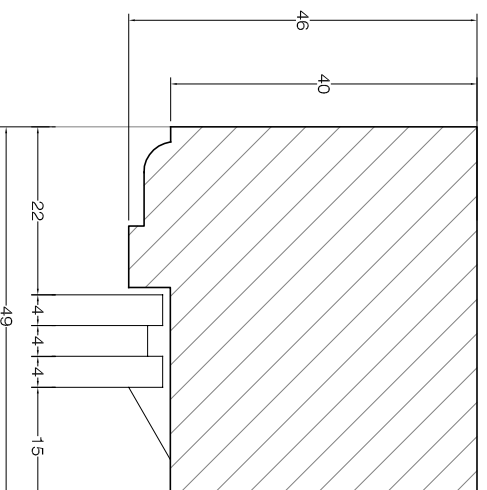

PROPOSED WINDOW
Detail 03 - Frame
SCALE 1/1@A3

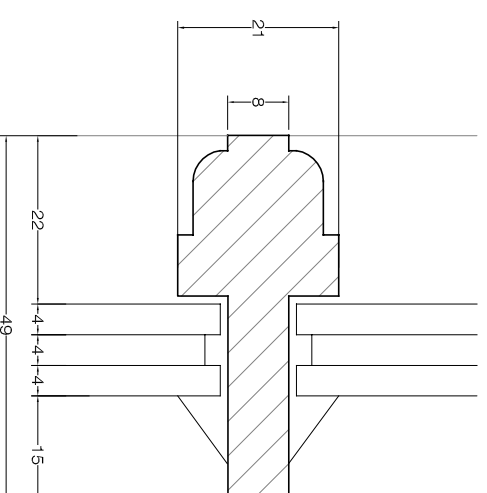

PROPOSED WINDOW
Detail 04 - Glazing Bar
SCALE 1/1@A3

PLEASE NOTE:

1. ALL DIMENSIONS TO BE CHECKED ON SITE BEFORE FABRICATION.
2. CONTRACTOR TO REFER TO ENGINEER'S DRAWINGS BEFORE PROCEEDING WITH WORKS.
3. ALL DRAWINGS AND DESIGNS ARE COVERED BY DESIGN RIGHT (INTELLECTUAL PROPERTY), AND MAY NOT BE DISTRIBUTED, COPIED OR ISSUE WITHOUT WRITTEN PERMISSION OF XUL ARCHITECTURE.
4. ALL DESIGN CONCEPTS ARE THE SOLE PROPERTY OF XUL ARCHITECTURE AND NO ADAPTATIONS, REPRODUCTIONS OR COPIES MAY BE MADE WITHOUT WRITTEN PERMISSION OF XUL ARCHITECTURE.
5. THESE DRAWINGS ARE SUBJECT TO ANY VARIATION REQUIRED OR RECOMMENDATION BY ANY STATUTORY AUTHORITY, OR FOR THE BETTER CARRYING OUT OF THE WORKS.
6. SAMPLES TO BE PROVIDED BY CONTRACTOR FOR XUL ARCHITECTURE APPROVAL.
7. ALL FINISHES TO XUL ARCHITECTURE SATISFACTION.
8. ALL DRAWINGS TO BE APPROVED BY XUL ARCHITECTURE BEFORE CONSTRUCTION.

ADDITIONAL NOTES:

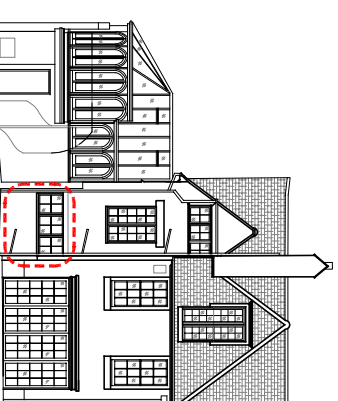

REVISIONS

No	Date	Description Issue For	Issue By
00	31/01/18	Planning	YR
01	23/04/18	Planning	YR

Client
PRIVATE CLIENT

Project
102 Frognal
London NW/3 6XU

Title
WINDOW DETAILS
Proposed Window

Scale	Dwg. No.	Rev.
1/20@A3	WD-02	01
Date	31/01/18	
Drawn	YR	
Checked	SS	
	Project Number	17 042