

01 Gate 01

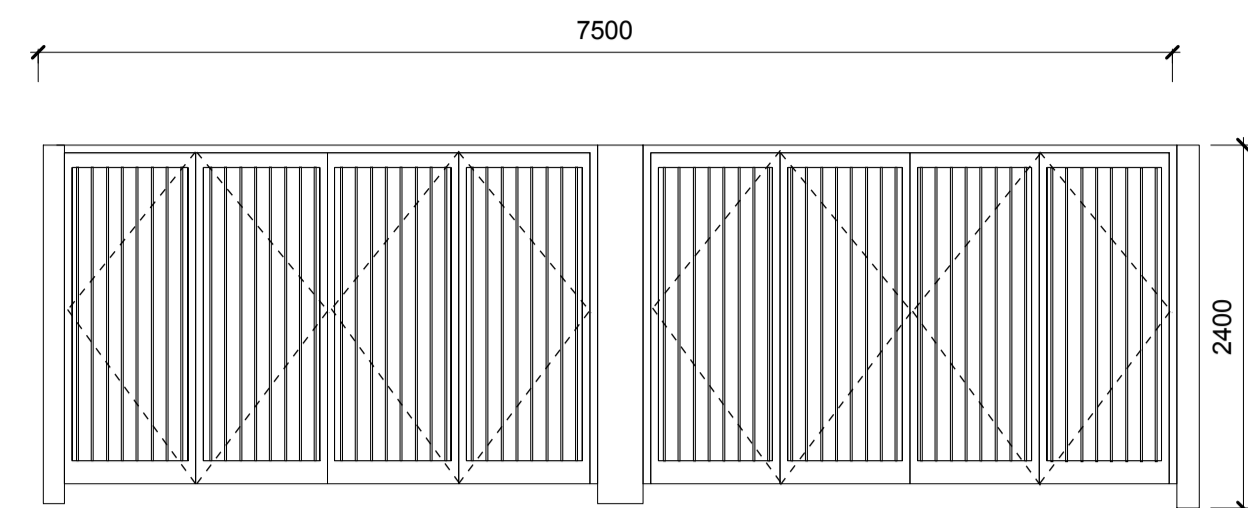

02 Gate A1

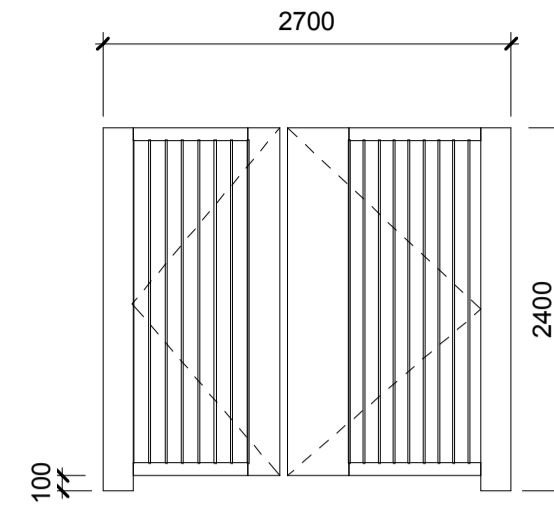

03 Gate A2

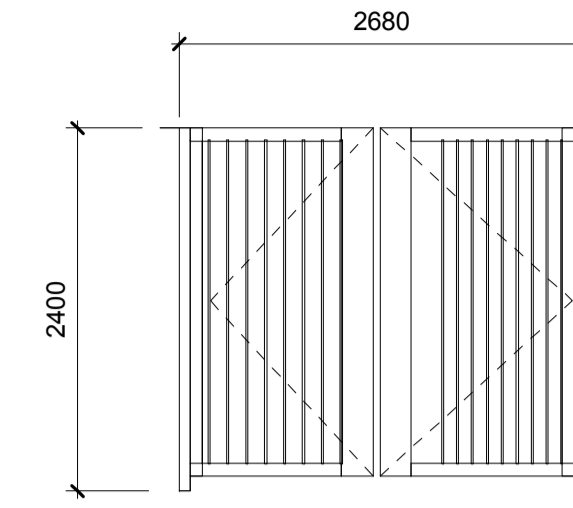

04 Gate 02

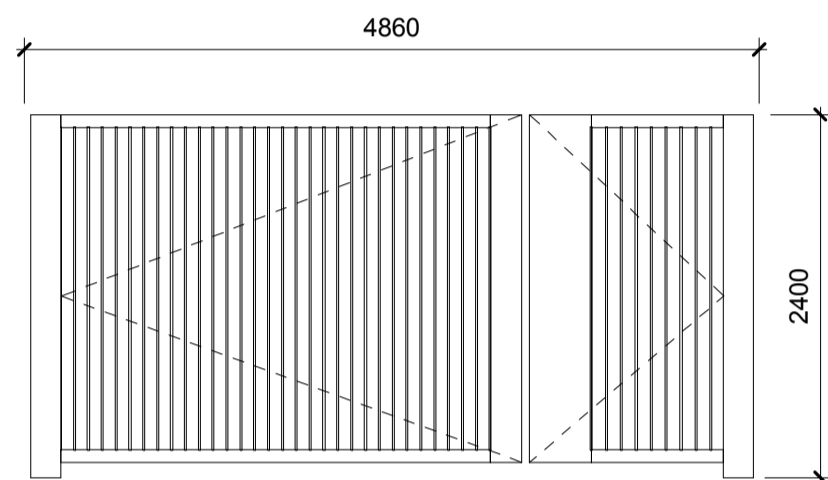

05 Gate 03

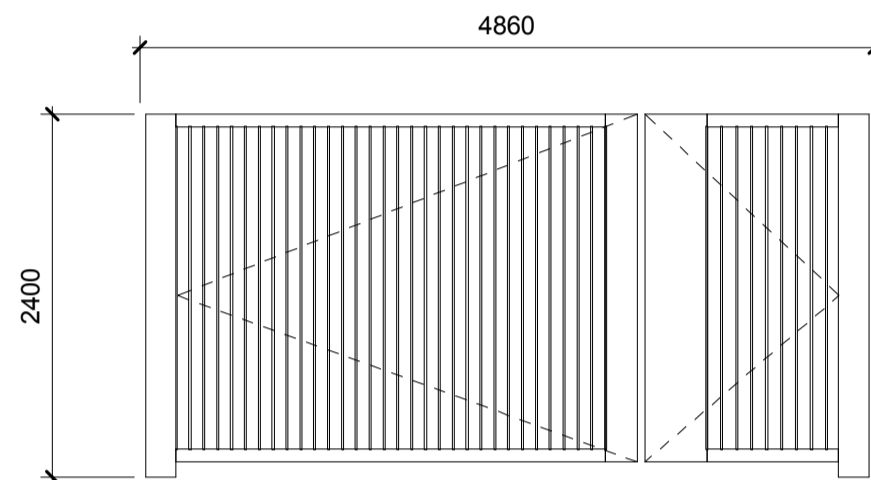

06 Gate 04

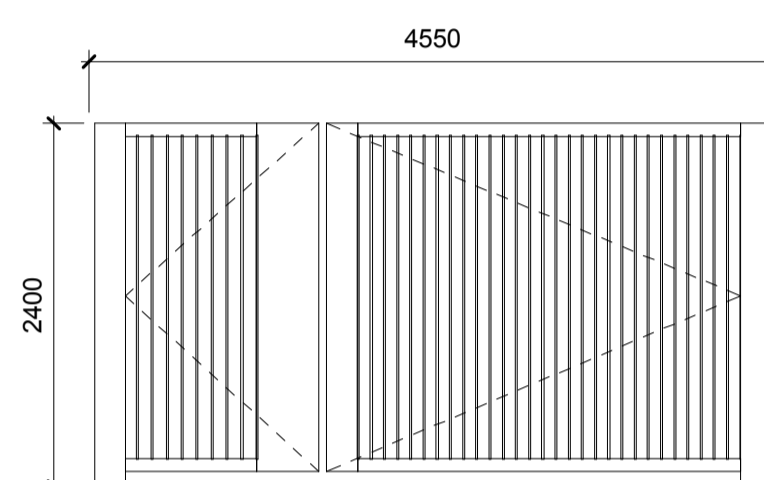

07 Gate 05

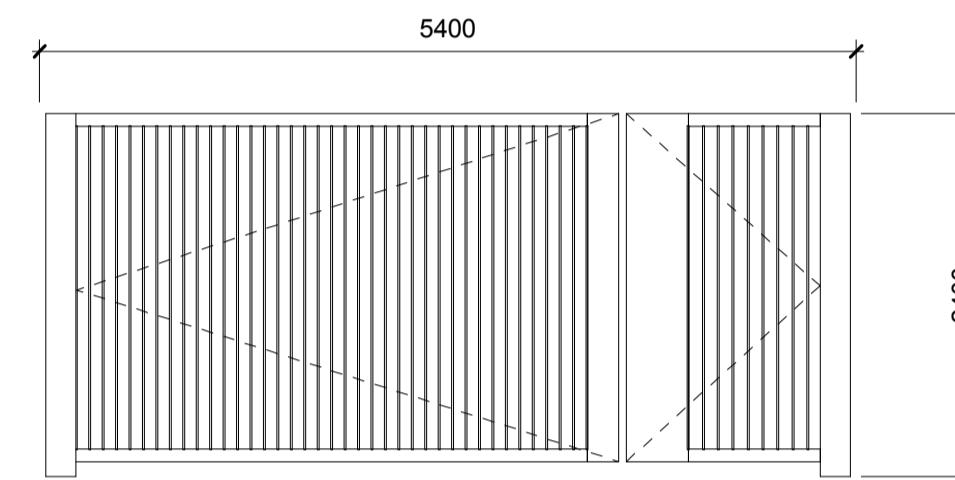

08 Gate 06

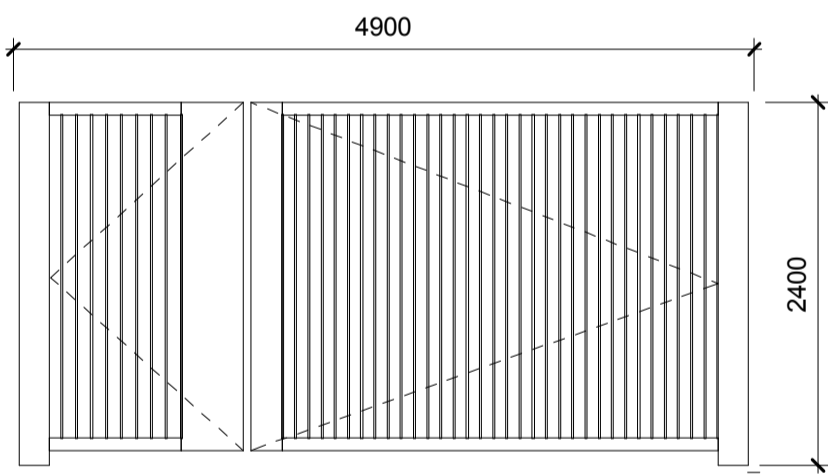

09 Gate 08

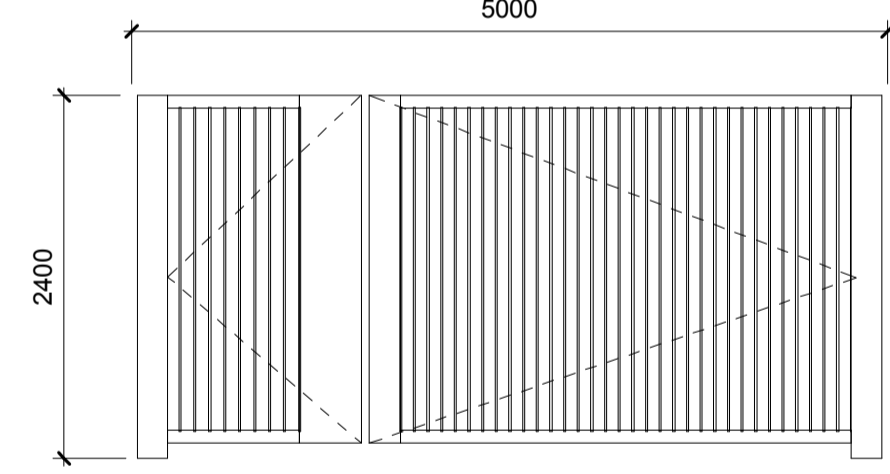

10 Gate 09

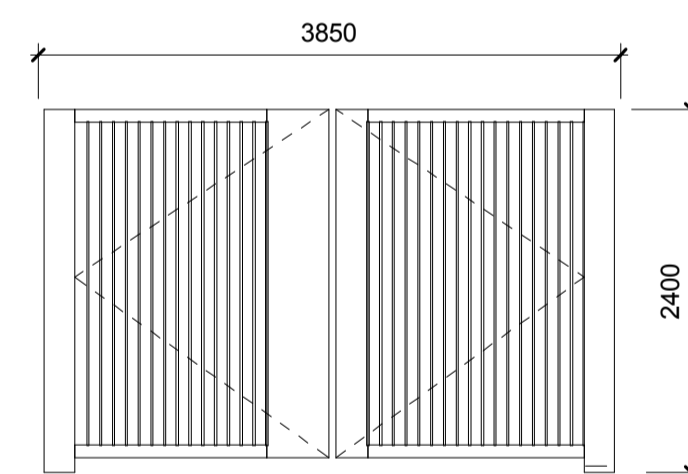

11 Gate 10

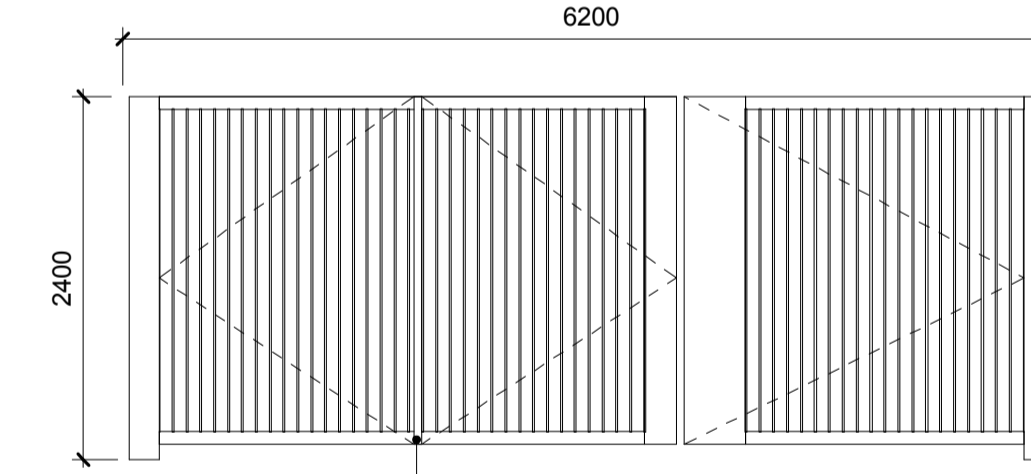

12 Gate 11

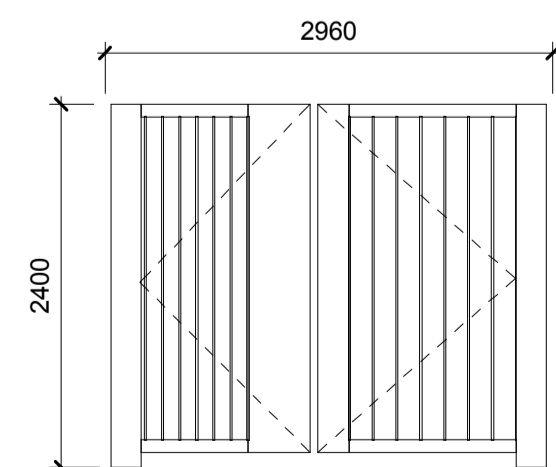

13 Gate 16

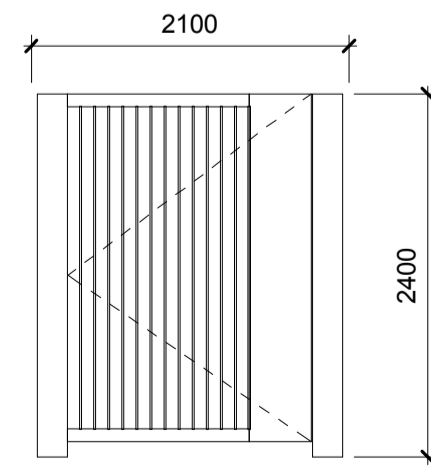

14 Gate 17

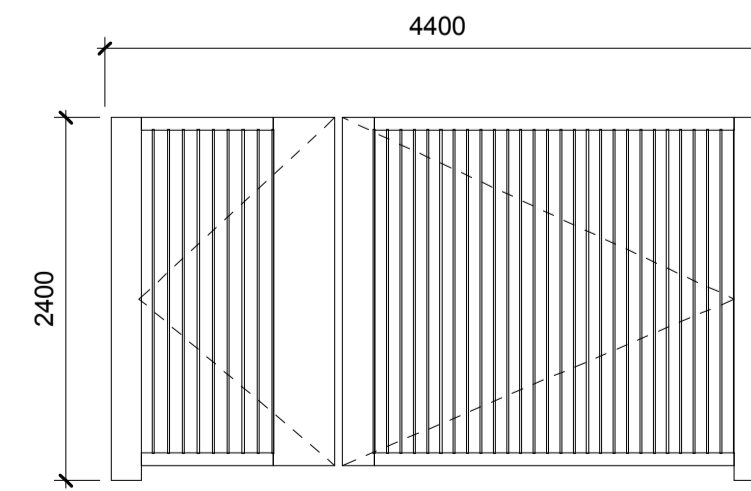

15 Gate 18

**KEY**  
 Masterplan: Refer to 14045\_MX\_(XX)\_XXXX for relevant drawings  
 Building A: Refer to 14045\_AX\_(XX)\_XXXX for relevant drawings  
 Building C: Refer to 14045\_CX\_(XX)\_XXXX for relevant drawings  
 Building DE: Refer to 14045\_DE\_(XX)\_XXXX for relevant drawings  
 Building WX: Refer to 14045\_WX\_(XX)\_XXXX for relevant drawings  
 Viaducts: Refer to 14045\_VX\_(XX)\_XXXX for relevant drawings

For Access & Maintenance refer to:  
 Building A: 14045\_A\_V\_RP002  
 Building C: 14045\_C\_W\_RP001  
 Building DE: 14045\_DE\_RP002  
 Building WX: 14045\_C\_W\_RP001  
 Viaducts: 14045\_A\_V\_RP002

Notes:  
 For Structural information refer to the Structural Engineers information.  
 For Below Ground Sitewide Drainage refer to the Civil Engineers information.  
 For Fire Strategy refer to Fire Engineers information.  
 For Landscape refer to the Landscape Architects information. All landscape levels to be confirmed by Landscape Architect.

FOR THE GATE SPECIFICATION REFER TO 14045\_V\_SP\_040

F01 05/05/17 For Coordination  
 REV DATE DESCRIPTION

CONSULTANTS	
CLIENT:	Stanley Sidings
CONTRACTOR:	Mace Group
STRUCTURAL ENGINEER:	Walsh Group
MECHANICAL ENGINEER:	Aecom
COST CONSULTANT:	Gardiner & Theobald
PROJECT MANAGER:	Gardiner & Theobald
ACOUSTIC CONSULTANT:	Hoare Lea
TRANSPORT CONSULTANT:	Arup
PLANNING CONSULTANT:	Gerald Eve
LANDSCAPE ARCHITECT:	Fabrik
CDM CO-ORDINATOR:	Gardiner & Theobald

- NOTE**
- Do not scale from this drawing.
  - All dimensions to be checked on site by the contractor and such dimensions to be his responsibility. Report all drawing errors, omissions and discrepancies to the architect.
  - This document may be issued in an uncontrolled CAD format to enable others to use it as background information to make alterations and/or additions. In that instance the file will be accompanied by a PDF version. It is for those making such alterations and additions to ensure that they make use of current background information.
  - AHMM Ltd accepts no liability for any such alterations or additions to the background information or arising out of changes to background information which occur prior to alterations or additions being made.

**Note**

All gates to meet accessibility requirements for widths and opening force  
 All gates within residential circulation routes to be provided with fob access and handles to permit free escape from inside  
 Handles / mechanisms etc to be suitable for use by people with limited strength and dexterity  
 Opening / closing force to be within 30N or gate will require automatic opening  
 All door casing assemblies to be tamper proof and external hinges to be provided with welded cover plates to prevent climbing  
 Emergency escape sign and statutory signage to be provided to gates within door casing zone  
 Gate lettering - design TBC  
 The height of the gates will be reviewed during Stage F to ensure coordination with transom heights of adjacent buildings

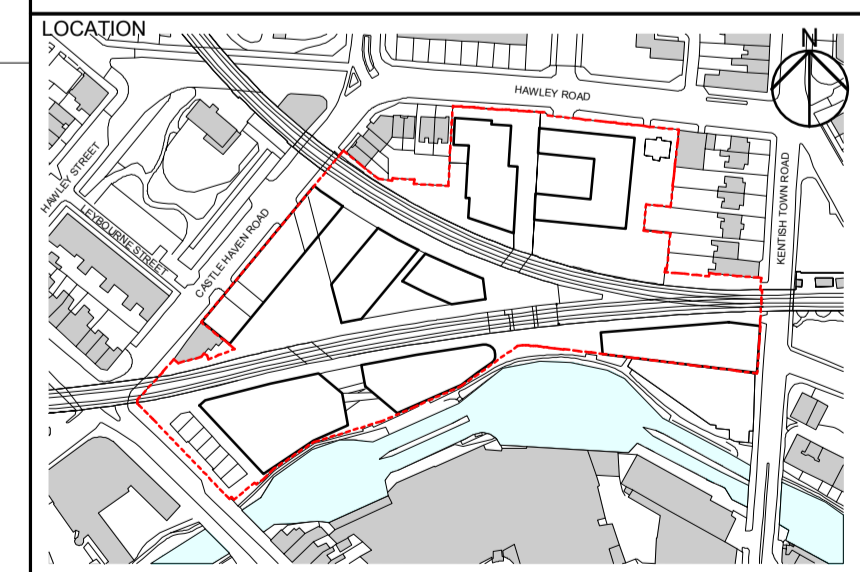

**ALLFORD HALL MONAGHAN MORRIS**  
 ARCHITECTS Ltd  
 5-23 OLD STREET, LONDON, EC1V 9HL  
 TEL 020 7251 5261 FAX 020 7251 5123 WEB WWW.AHMM.CO.UK

job title  
**Camden Lock Village**  
 drawing title / location  
**Gates Scope Drawing**

drawn by	checked	scale	status
MP	AH	1 : 50 @ A1	For Coordination

project	drawing no.	revision
14045	MX_(67)_1100	F01