

Rev	Date	Details	Drawn by	Checked by
A	12/07/2017	Preliminary issue for information/comment	PV	BL
B	07/12/2017	Window horns added	CM	BL
C	20/02/2018	Frame details amended	CM	BL
D	05/04/2018	Frame details amended to double glazed windows	CM	BL

This contract must state all dimensions, levels and services to be provided. It is the contractor's responsibility to verify all dimensions, levels and services to be provided. The contractor must ensure that all dimensions, levels and services are provided in accordance with the contract documents. The contractor must ensure that all dimensions, levels and services are provided in accordance with the contract documents.

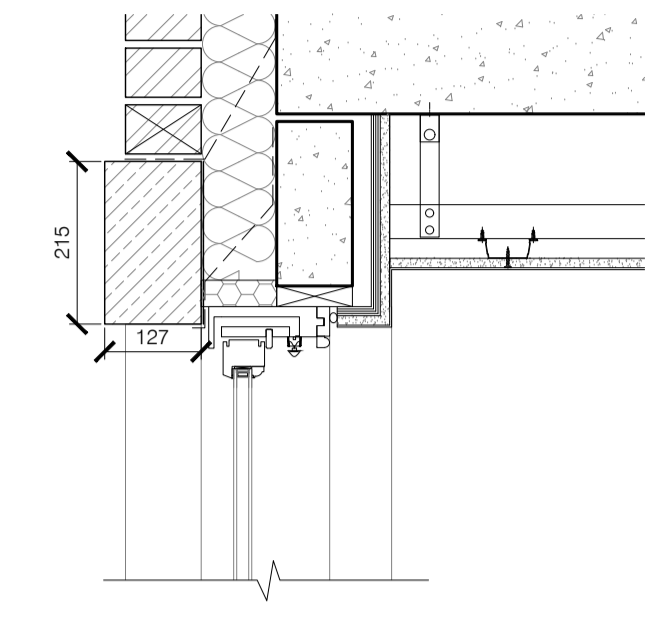

Section B-B
Typical window head and sill detail
Scale 1:10

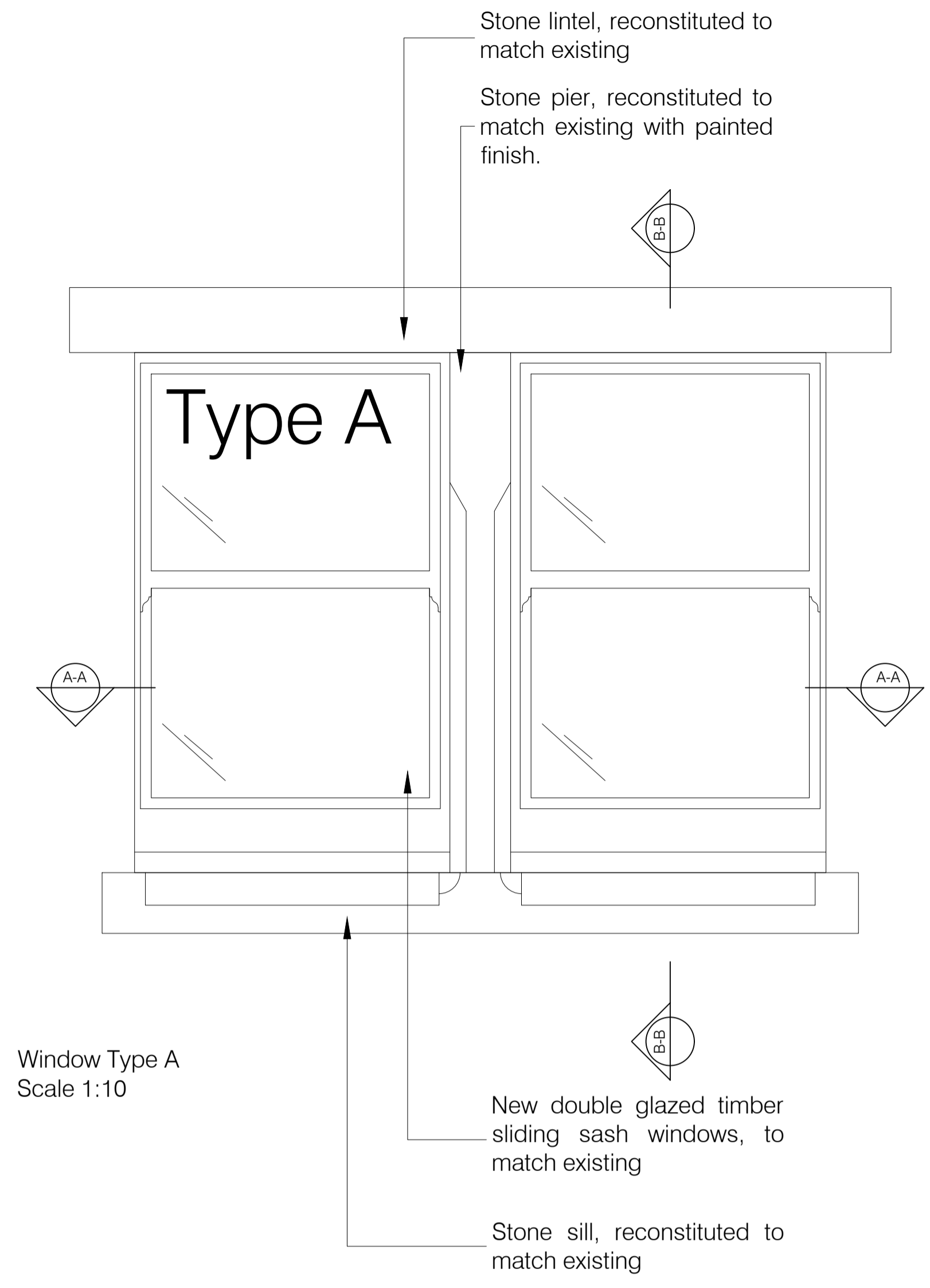
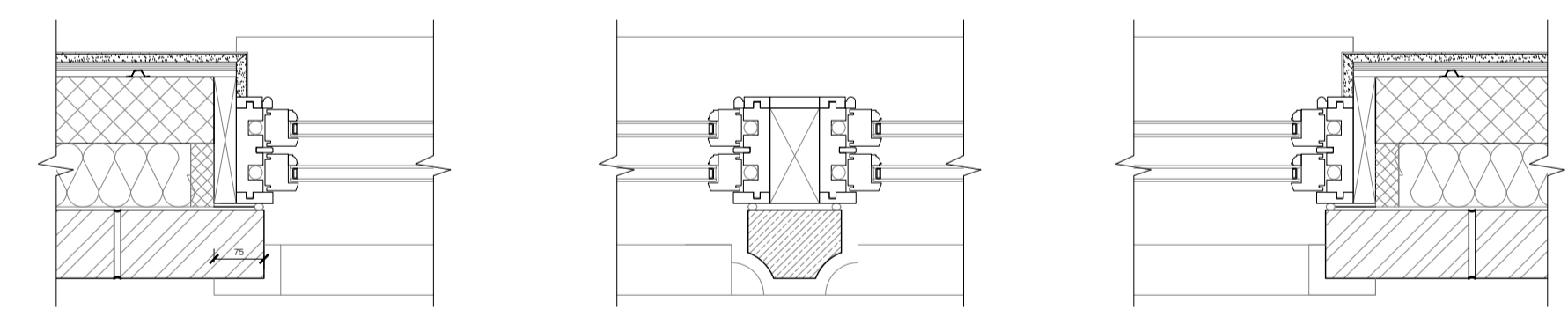

Section A-A
Typical jambs and sash window detail mullion
Scale 1:10

Read in conjunction with drawing (03)15



S & T (Ltd)
client name

18-20 Elsworth Road
London
NW3 3DJ

project

Typical Window Detail
Type A

title

Planning

status

17/07/2017 PV
date drawn

1:10 @ A1 BL
scale checked

(03)25
drawing number

D 832-01
revision job number

