

Rev	Date	Details	Drawn by	Checked by
A	24/01/18	Issued for condition 2 discharge	CM	BL
B	21/03/18	Issued for condition 2 discharge	CM	BL

The contractor must check all dimensions, levels and service post to ensure compliance with all relevant building regulations and standards. The contractor must ensure that all materials are of the correct specification and that all work is carried out in accordance with the approved drawings. The drawings must be read in conjunction with the project and specification documents. The drawings must be read in conjunction with the project and specification documents.

Roof Type A (Main Roof)

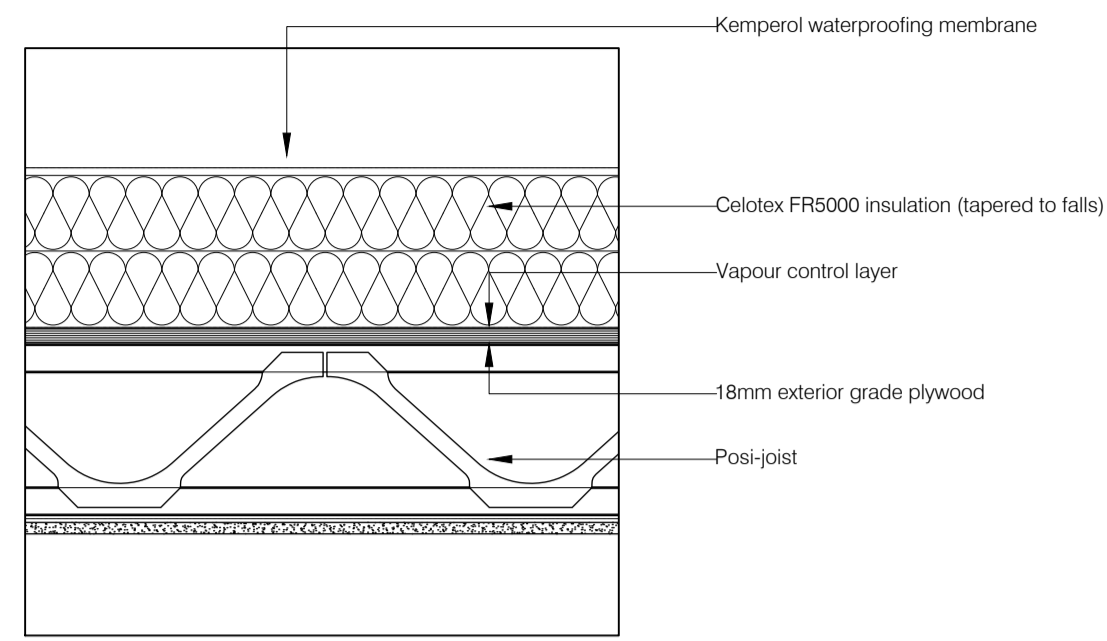

Roof Type B (Green Roof)

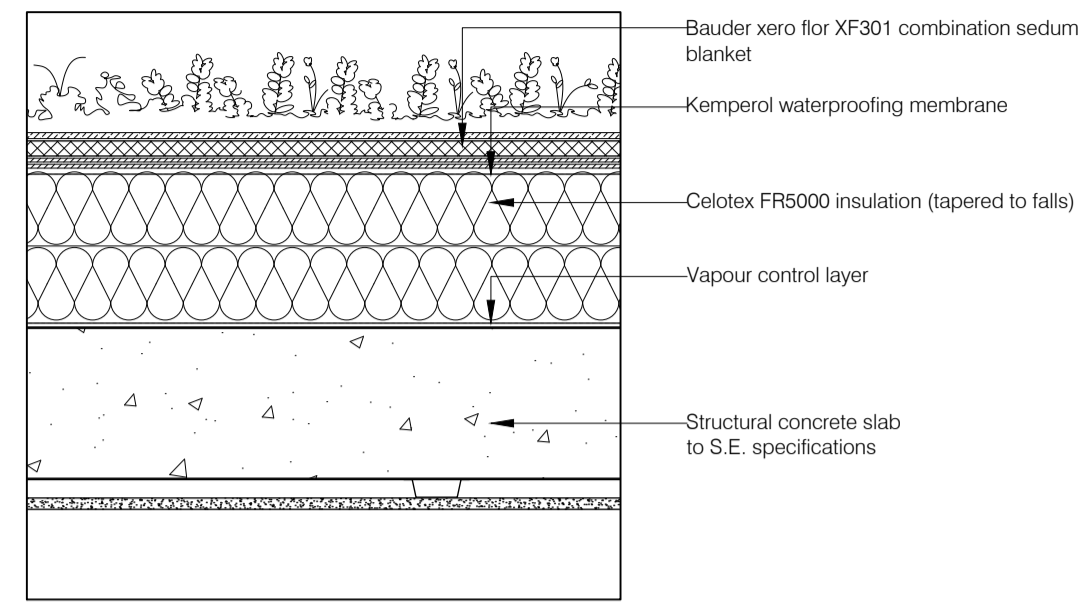

Roof Type C (Rear Garden Paving)

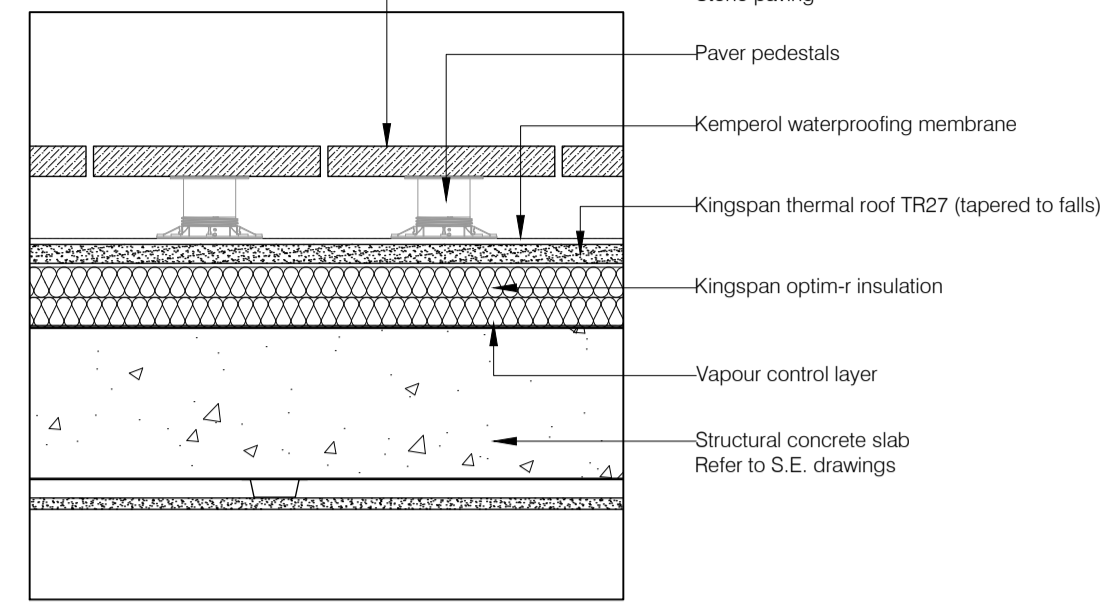

Roof Type D (External Paving)

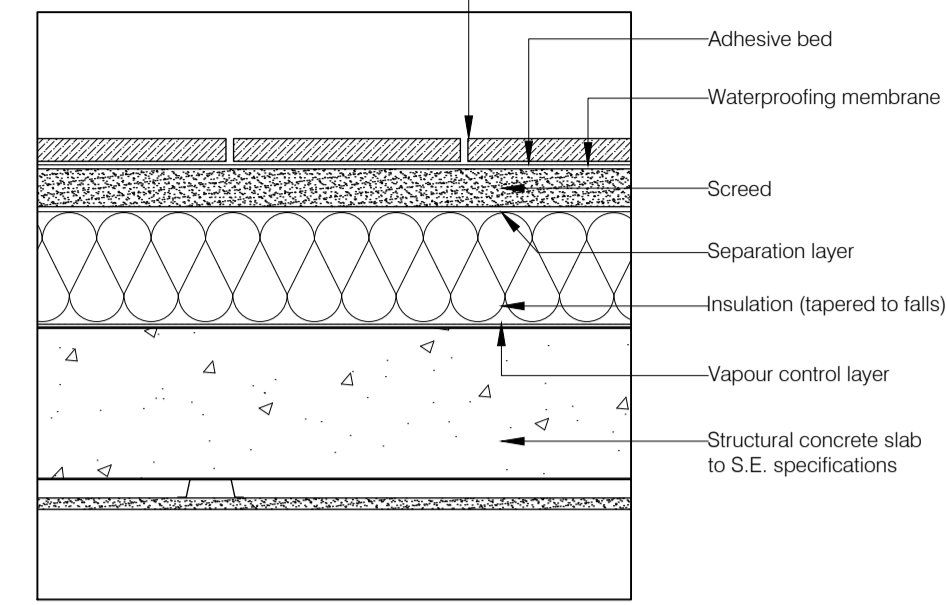

Roof Type E (Mansard)

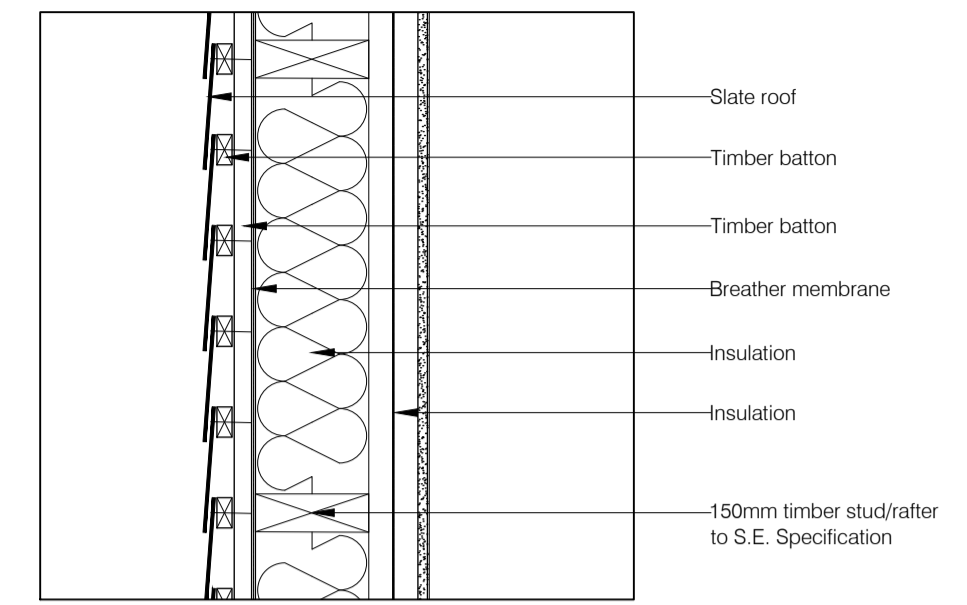

1. Mansafe Detail

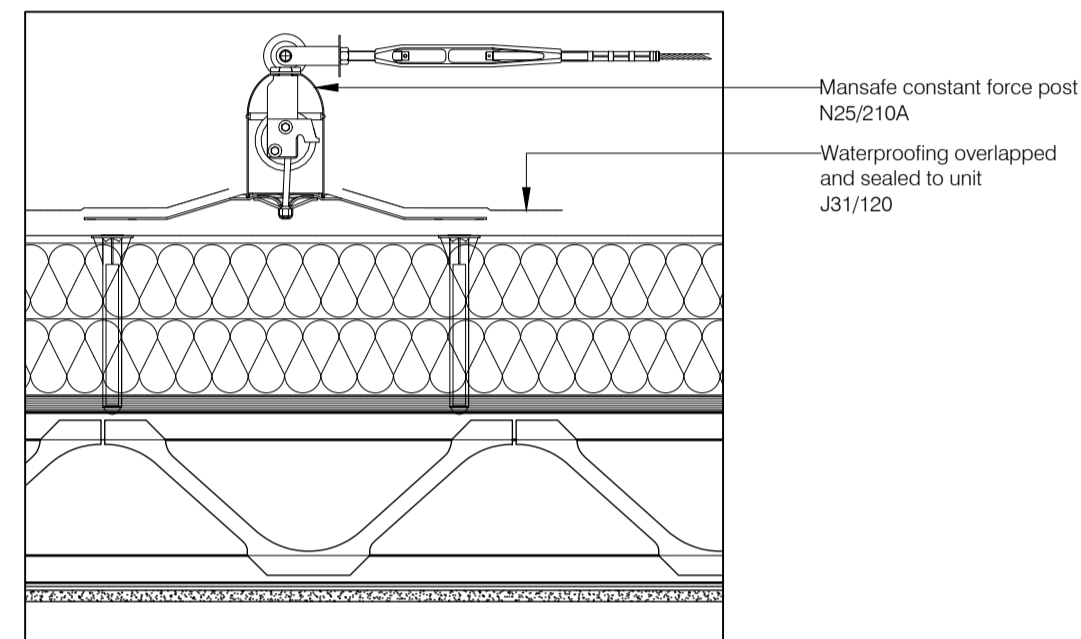

2. Velux Detail

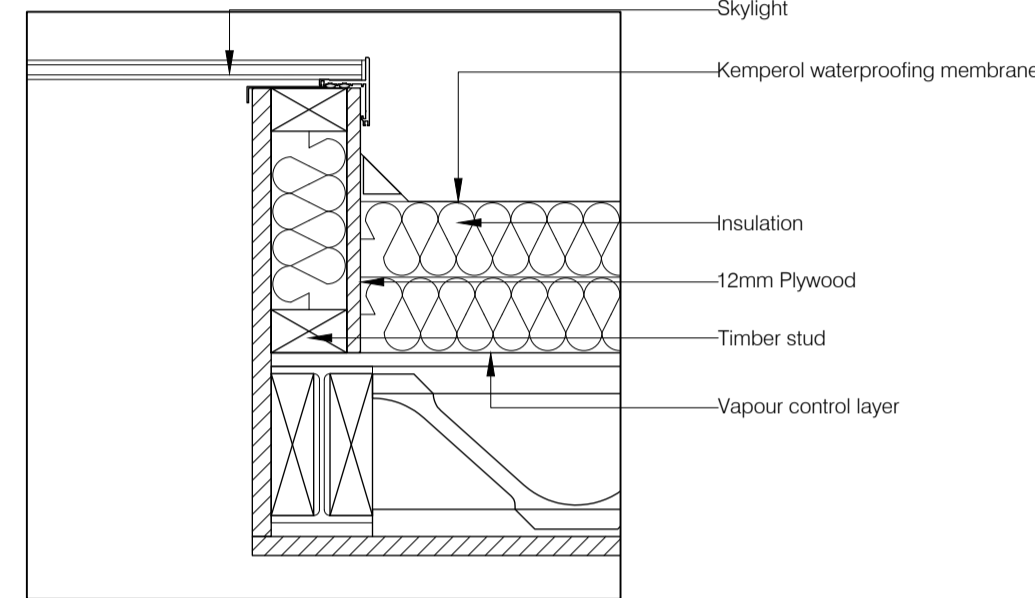

3. Mansard / Wall junction

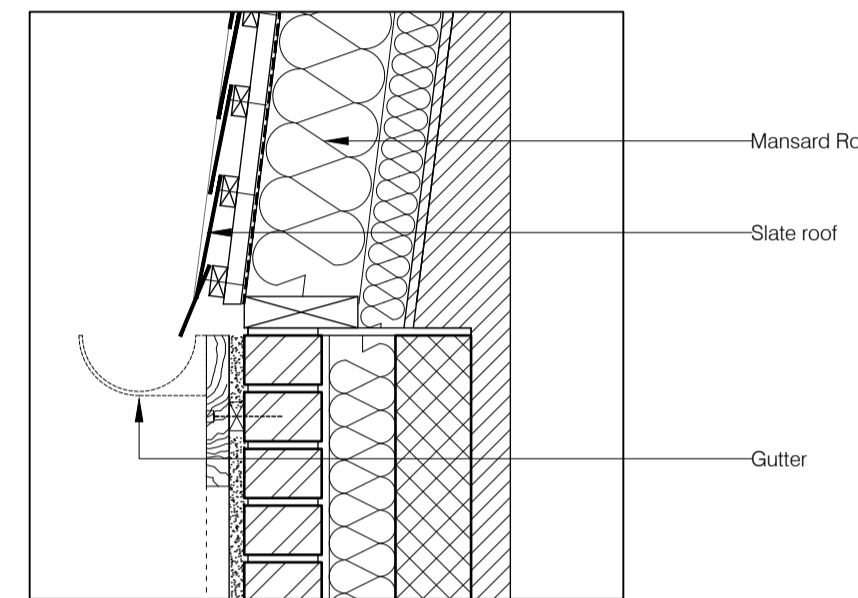

4. Dormer Roof Detail

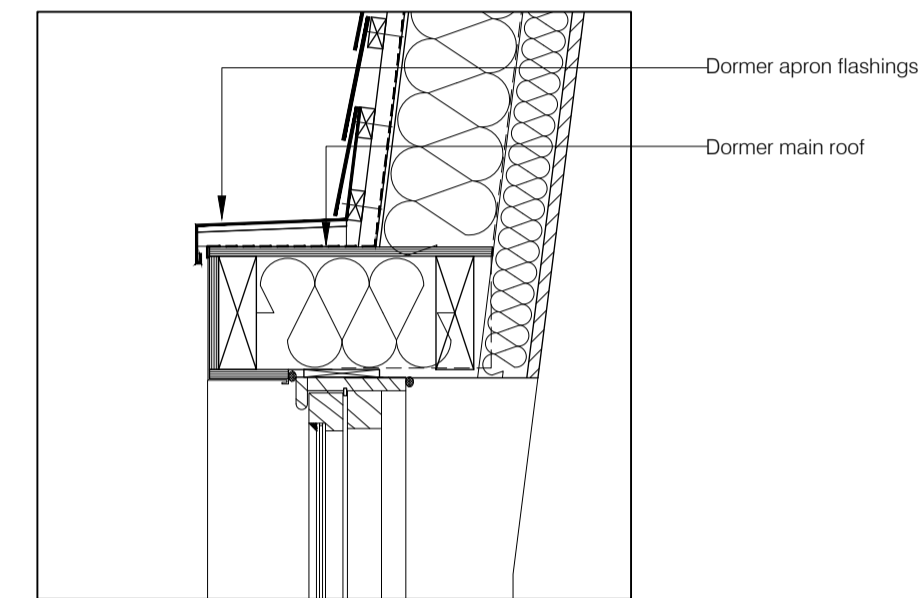

5. Mansard Junction

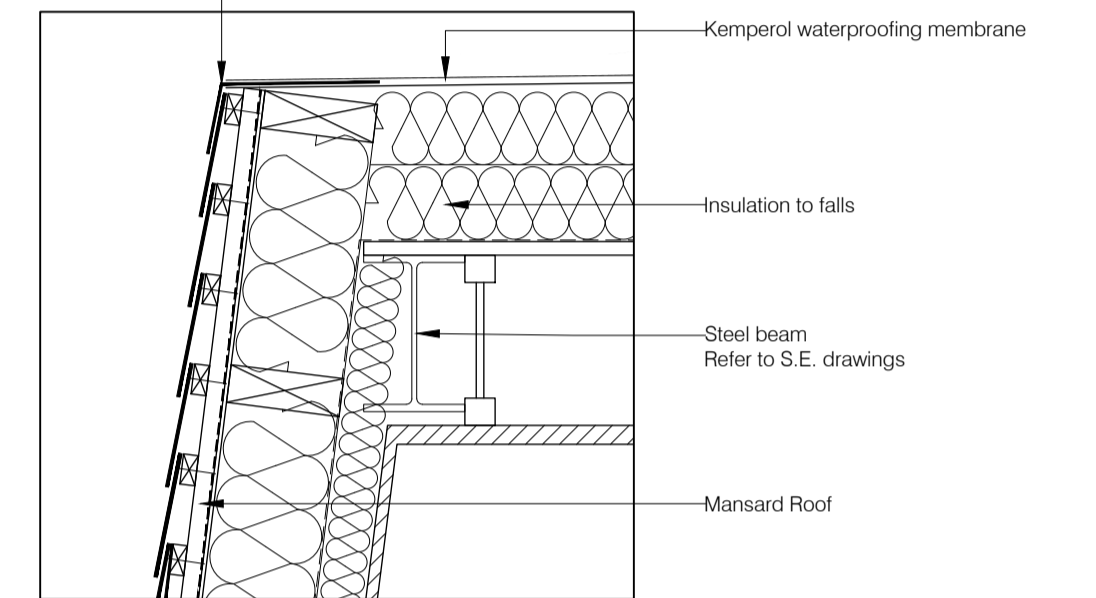

6. Central Parapet

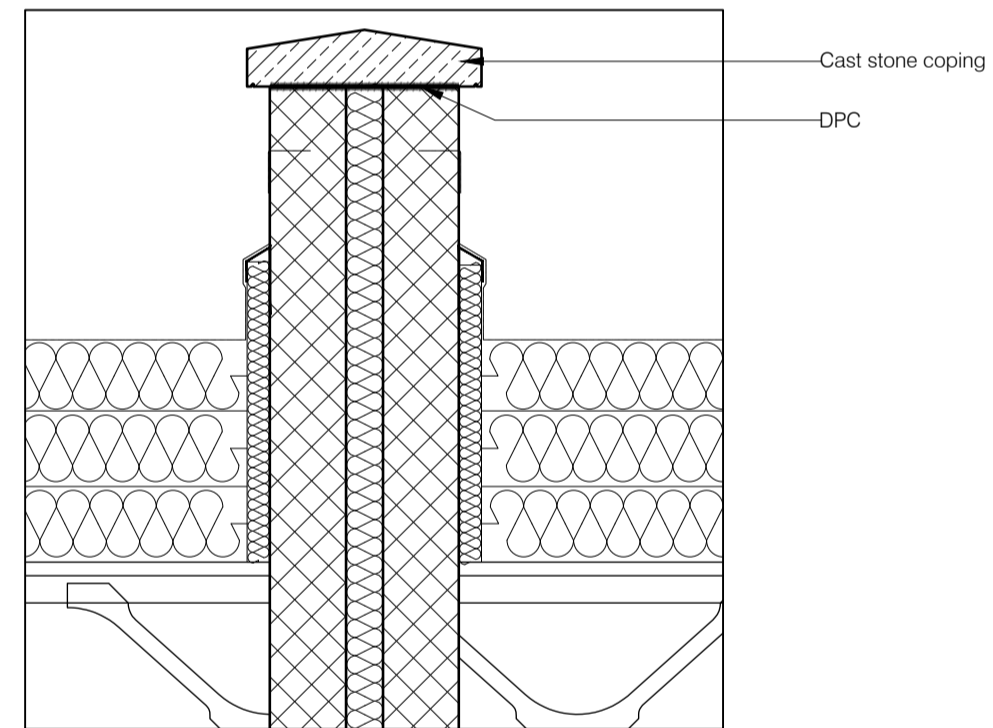

8. Front Gable

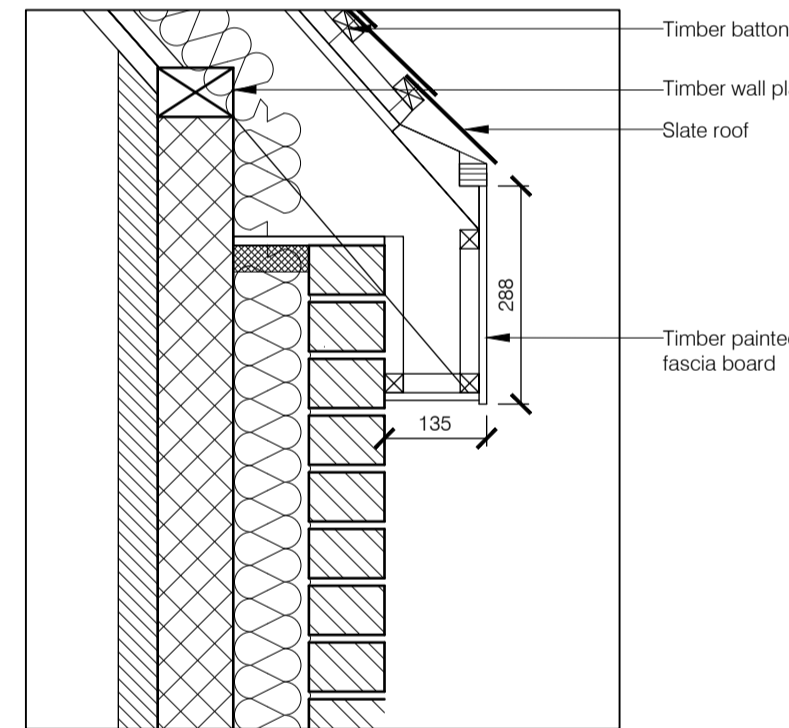

10. Rear Bay Window

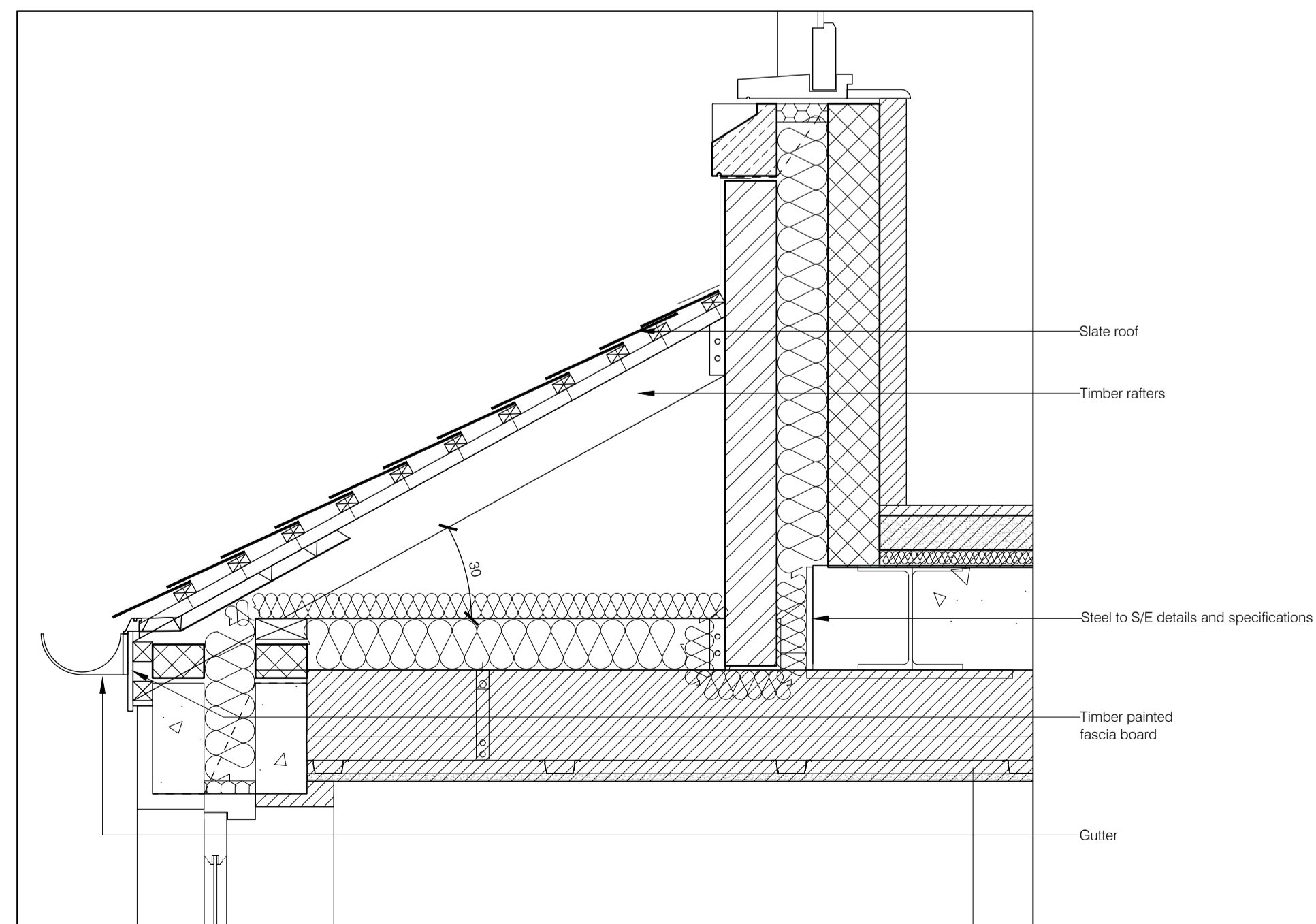

9. Barge Board

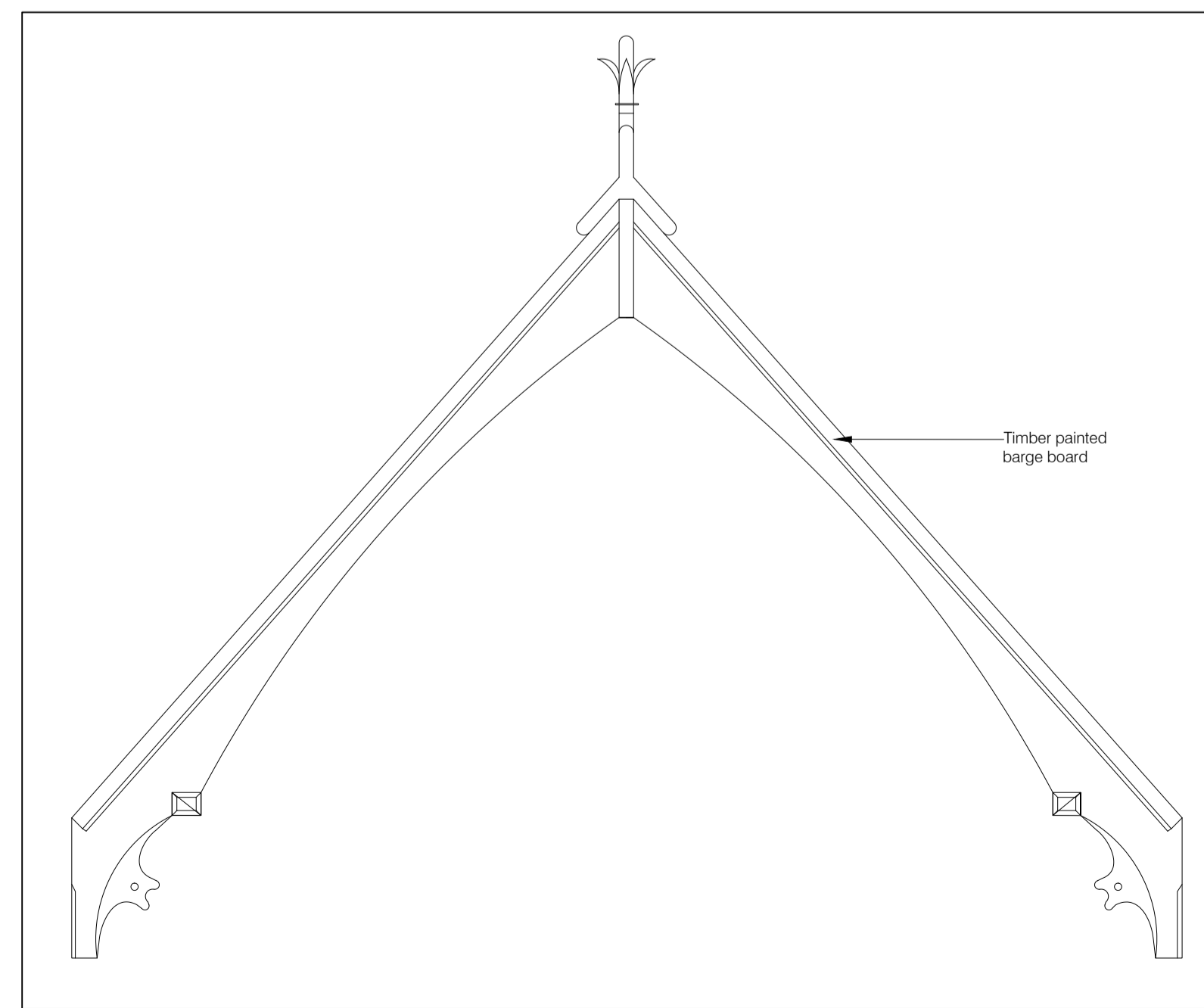

Refer to (03)20 for key plan
 Read in conjunction with drawings: (03)16 to (03)39



client name	
S & T (Ltd)	
18-20 Elsworth Road London NW3 3DU	
project	
Proposed Roof Details	
title	
Planning	
status	
date	11/01/18
drawn	PV
scale	1:10 @ A1
checked	AH
drawing number	
(03)40	
revision	B
job number	832-01

