

1:10 elevation

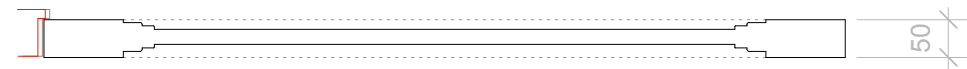

1:10 plan



1:10 section

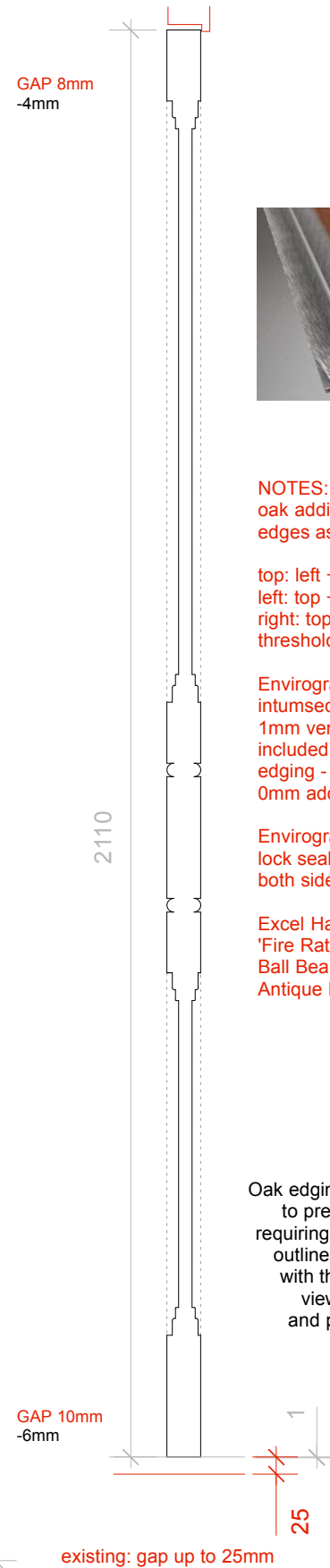

NOTES:
oak additions to door edges as follows:
top: left +4mm - right +12mm
left: top +2mm - base +4mm
right: top +4mm - base +6mm
threshold: left +6mm - right +6mm

Envirograf ES/SDW oak veneer intumescet/smoke brush seal 1mm veneer thickness to be included in the additional oak edging - seal only applied where 0mm addition is indicated.

Envirograf intumescent lock seal inserted to both sides of lock case/keep

Excel Hardware 4 Inch 'Fire Rated' Solid Steel Ball Bearing Hinges, Antique Brass - XL869-ANB

Oak edging set back 4mm from inner face to preserve worn/rounded corner from requiring planing and to allow the original outline of the door to remain readable - with the additional edge receding from view from the room. Edging bonded and pinned with brass lost head pins.

detail 1:5- head

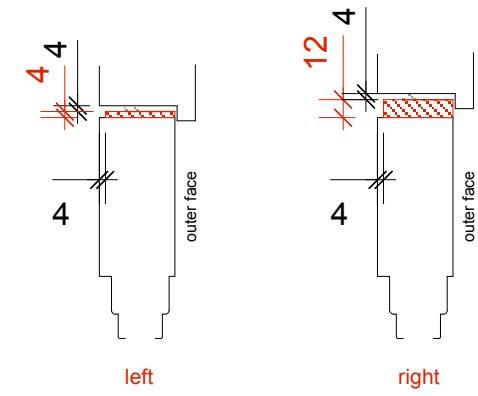

detail 1:5- jambs

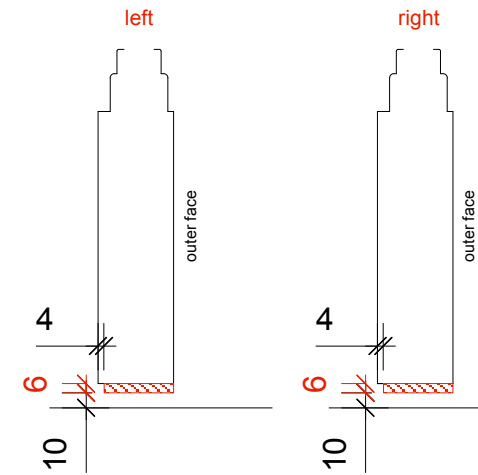
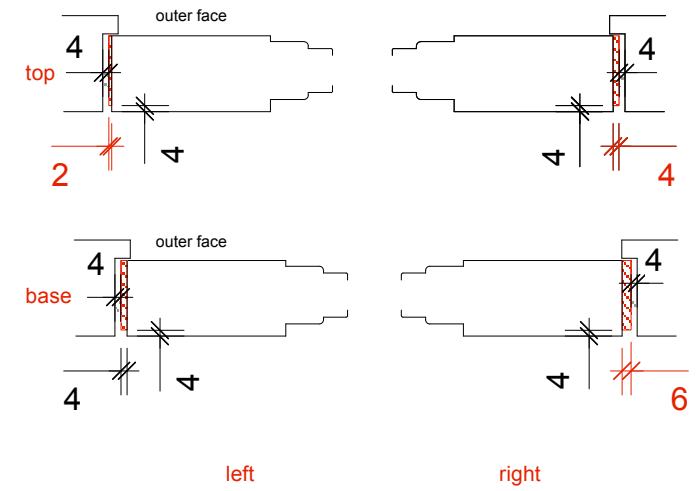

detail 1:5- threshold

notes: