

Drawing: 01EP

EXISTING AND PROPOSED ELEVATION & SECTION

Top floor, 30 Parliament Hill, NW3 2TN

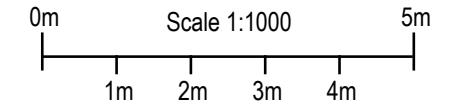

Existing and Proposed REAR ELEVATION (FROM EAST)
(top floor – 2nd and 3rd floor)
Proposal: Replace balcony sliding door like-for-like design

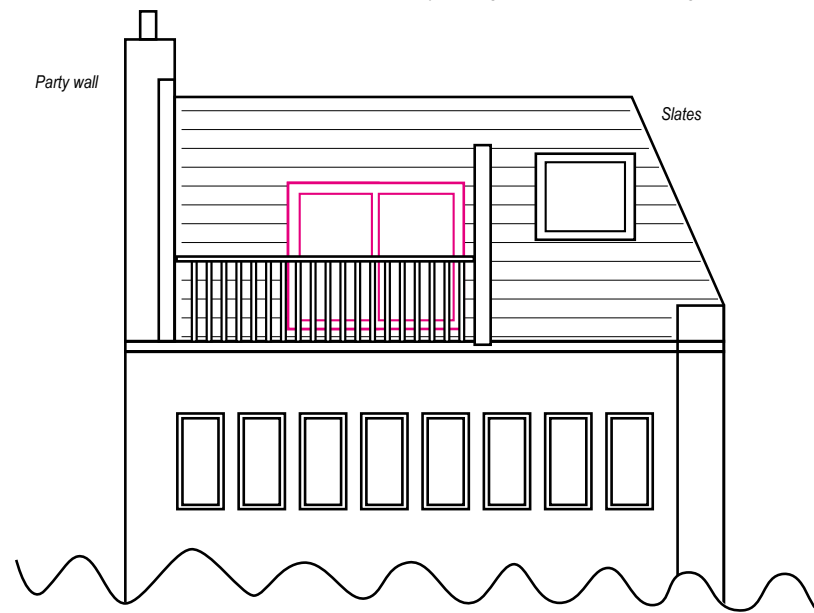

Note:
Proposed new balcony sliding door sits in the same position and size of existing one.

Existing and Proposed REAR SECTION (FROM EAST)
(top floor – 2nd and 3rd floor)
Proposal: Replace balcony sliding door like-for-like design

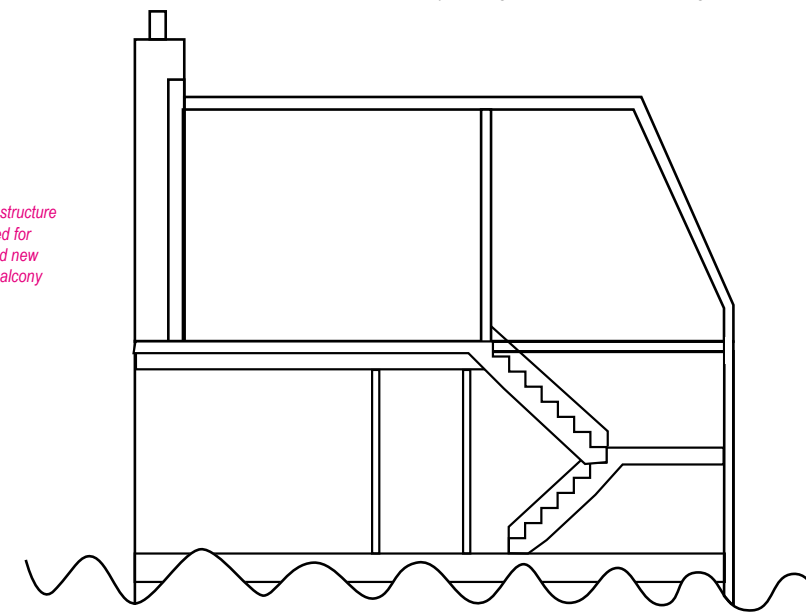

Note:
No new structure is needed for proposed new sliding balcony door

Existing and Proposed SIDE ELVATION (FROM NORTH)
(top floor – 2nd and 3rd floor)
Proposal: Replace balcony sliding door like-for-like design

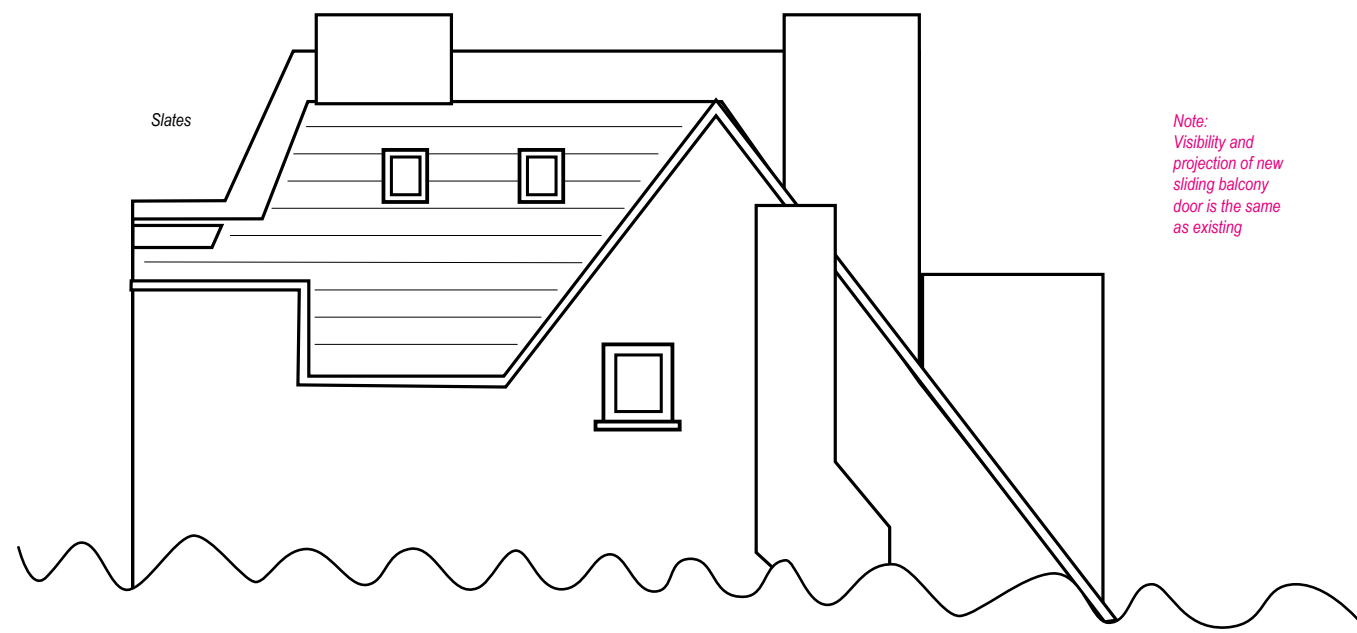

Note:
Visibility and projection of new sliding balcony door is the same as existing

Existing and Proposed SIDE SECTION (FROM NORTH)
(top floor – 2nd and 3rd floor)
Proposal: Replace balcony sliding door like-for-like design

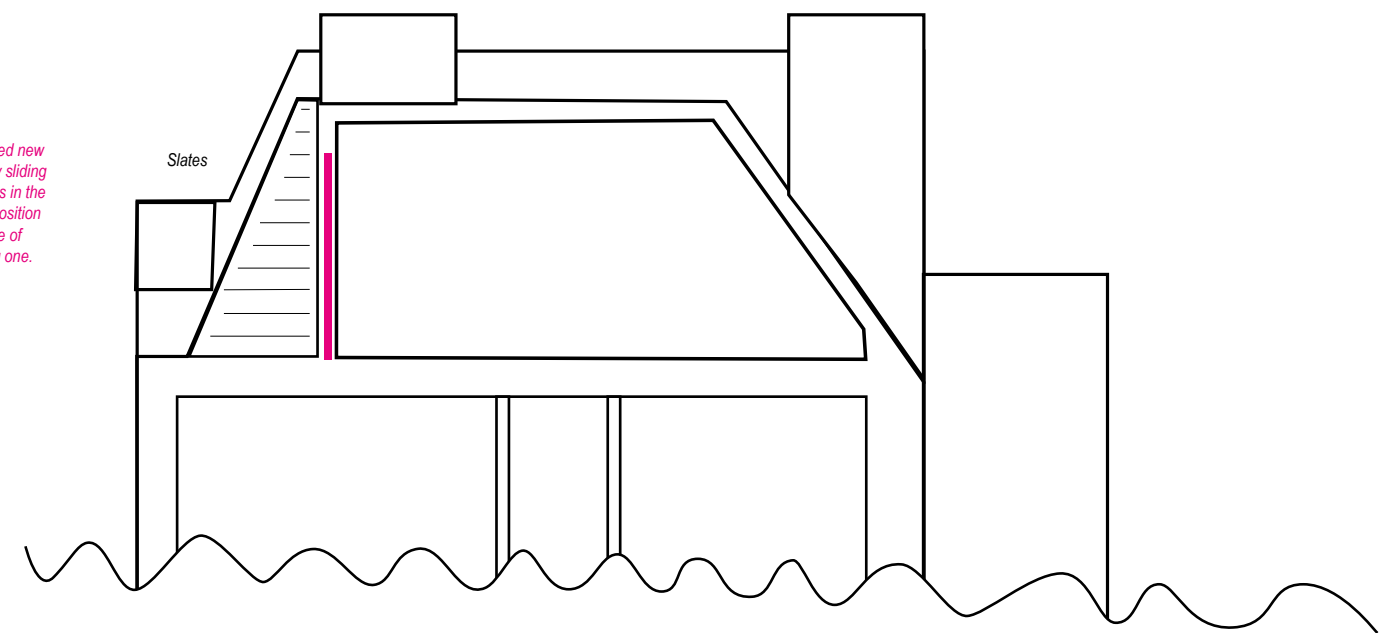

Note:
Proposed new balcony sliding door sits in the same position and size of existing one.