

GROUND FLOOR

- 1-OFF TOSHIBA RAV SM1402UT-E CASSETTE STYLE AHU. SUSPENDED FROM CEILING VIA M8 ROD & SLOTTED CHANNEL. SIZE: 355Hx950Wx950D WT-30.5KG EACH
- 2-OFF TOSHIBA RAV SM1102UT-E CASSETTE STYLE AHU. SUSPENDED FROM CEILING VIA M8 ROD & SLOTTED CHANNEL. SIZE: 355Hx950Wx950D WT-30.5KG EACH
- 1-OFF TOSHIBA RAV SM14001AT-E CONDENSOR UNIT ON P.V.C. CURBS. SIZE: 795Hx900Wx320D WT 77KG
- 2-OFF TOSHIBA RAV SM1101AT-E CONDENSOR UNIT ON P.V.C. CURBS. SIZE: 795Hx900Wx320D WT 77KG EACH
- 1-OFF 2000 GENERAL EXTRACT INLINE FAN
- 1-OFF 1500 GENERAL EXTRACT INLINE FAN
- 1-OFF 'AIRBLOC' ACR200SE18 ELECTRIC AIR CURTAIN 18kW. SIZE: 1982Wx200Hx395D

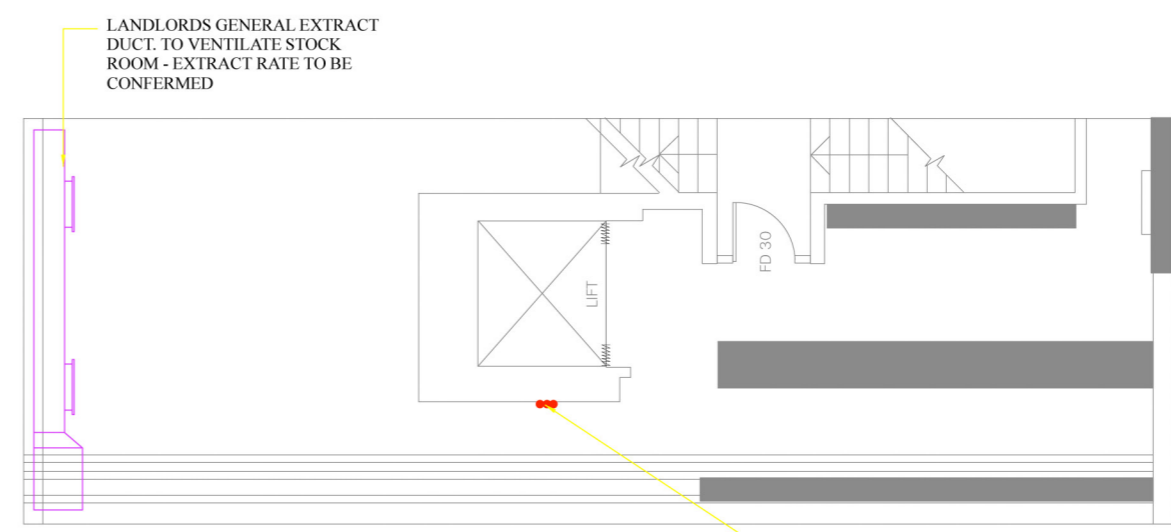

UPPER BASEMENT

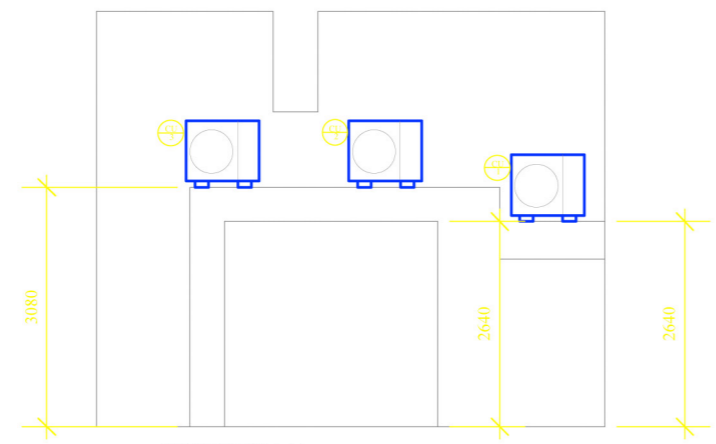

SECTION OF 'A-A'

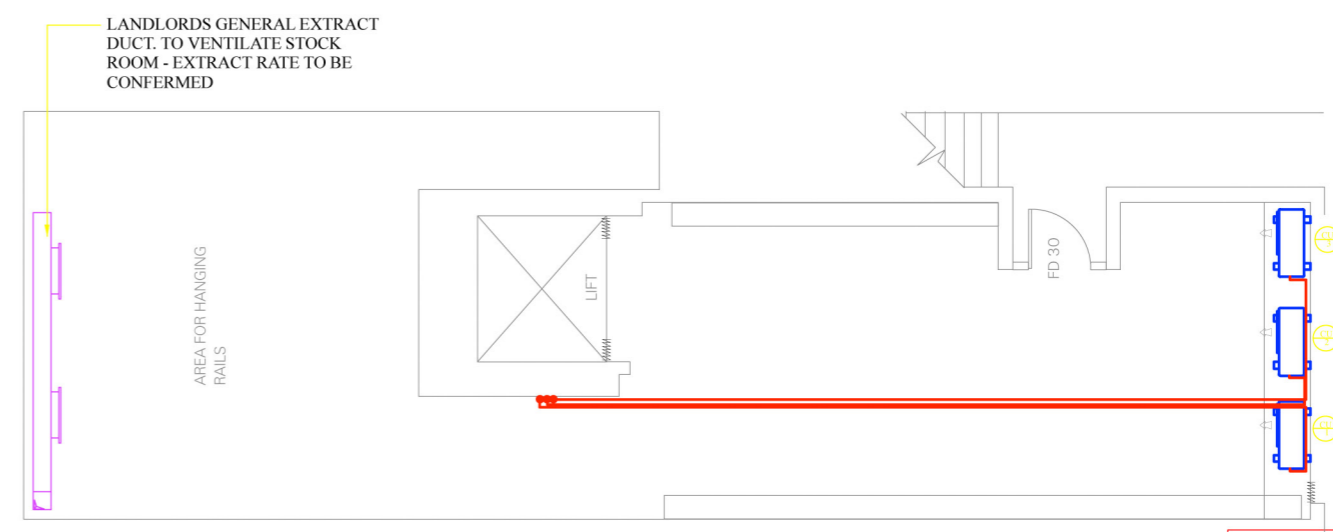

LOWER BASEMENT

DRG. LOCATION -

© COPYRIGHT OF THIS DRAWING RESIDES WITH FAN RESCUE LTD

NOTES  
1. DO NOT SCALE FROM THIS DRAWING, USE FIGURED DIMENSIONS ONLY, AND CHECK ALL DIMENSIONS ON SITE.

Rev	Date	CAD	Chkd	Description

Project  
**ICCO - BURNWICK CENTRE**

Drawing  
**EXISTING VENTILATION SURVEY**

**FAN RESCUE LTD**  
BATH HOUSE, PETERSFIELD ROAD  
WHITEHILL, HAMPSHIRE  
GU35 9BU  
TEL: 01420 477 570  
Email: enquires@fanrescue.co.uk

Scale 1:50	Size A1	Engineer IN	Date 12.03.2018
---------------	------------	----------------	--------------------

Drawing No.  
**FR-ICCO-E001**

Rev  
**P1**