

GENERAL NOTES:

This drawing remains the property of Locksley Architects Ltd, reproduction shall only be allowed with written permission.

This drawing is not to be scaled for construction purposes, use written dimensions only. Any discrepancies to be reported to the architect. All dimensions to be checked on site. The contractor is responsible for all dimensions and setting out of the work on site. The contractor must ensure that all elements of the work comply with current building regulations.

PROJECT NOTES:

Survey provided by client and Locksley Architects Ltd do not accept responsibility for any discrepancies

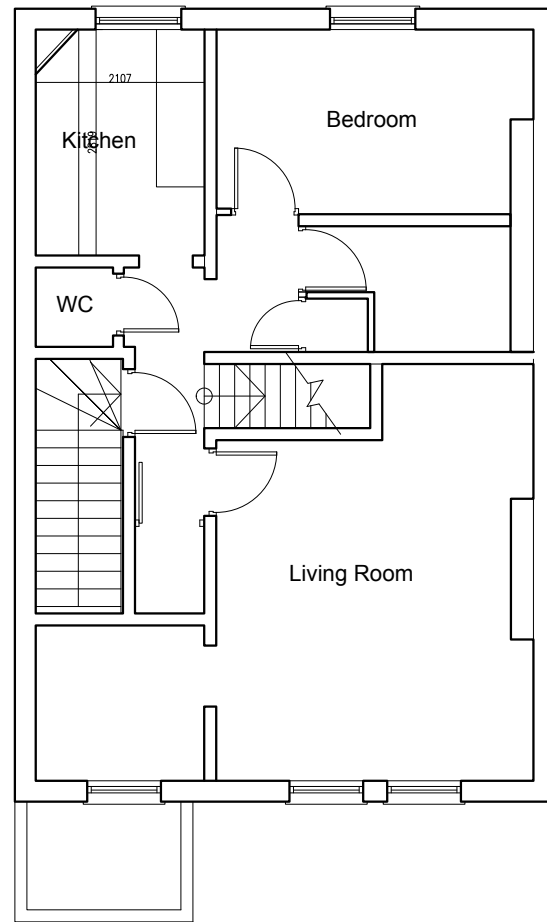

EXISTING SECOND FLOOR PLAN
58m2

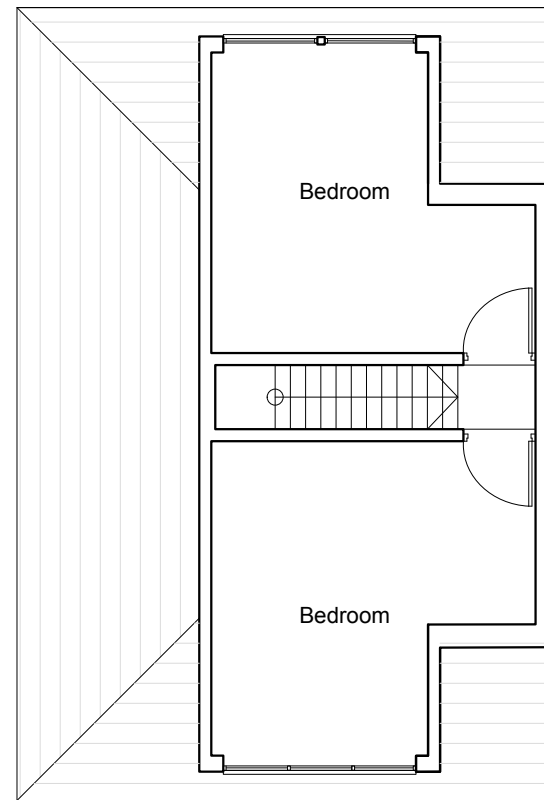

EXISTING THIRD FLOOR PLAN
37m2

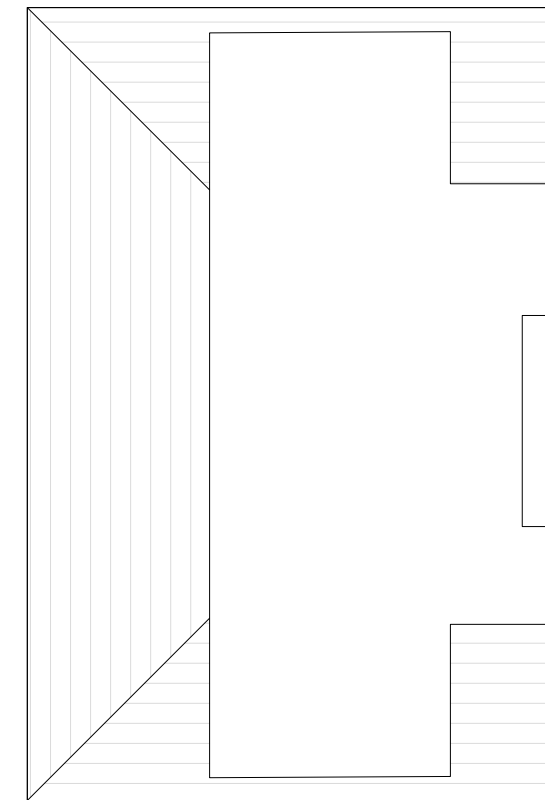

ROOF PLAN

SURVEY DRAWING SUPPLIED BY OTHERS

SCALE - 1:100 @ A3

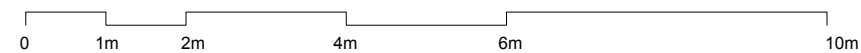

Issued for Planning	15/03/2018	B
Issued for Client Approval	10/02/2018	A
Revision Description	Date	Rev



LOCKSLEY
ARCHITECTS

Architect Details
Westbourne Studios, Notting Hill, London W10 5JJ
info@locksleyarchitects.com
0207 206 2727

Project
74 Parkhill Road

Title
EXISTING PLANS

Job No 0873	Drg No 110	Revision B
-----------------------	----------------------	----------------------

GENERAL NOTES:

This drawing remains the property of Locksley Architects Ltd, reproduction shall only be allowed with written permission.

This drawing is not to be scaled for construction purposes, use written dimensions only. Any discrepancies to be reported to the architect. All dimensions to be checked on site. The contractor is responsible for all dimensions and setting out of the work on site. The contractor must ensure that all elements of the work comply with current building regulations.

PROJECT NOTES:

Survey not provided by client and Locksley Architects Ltd do not accept responsibility for any discrepancies - Rear elevation estimated as no access was provided



74 Parkhill Road

EXISTING FRONT ELEVATION

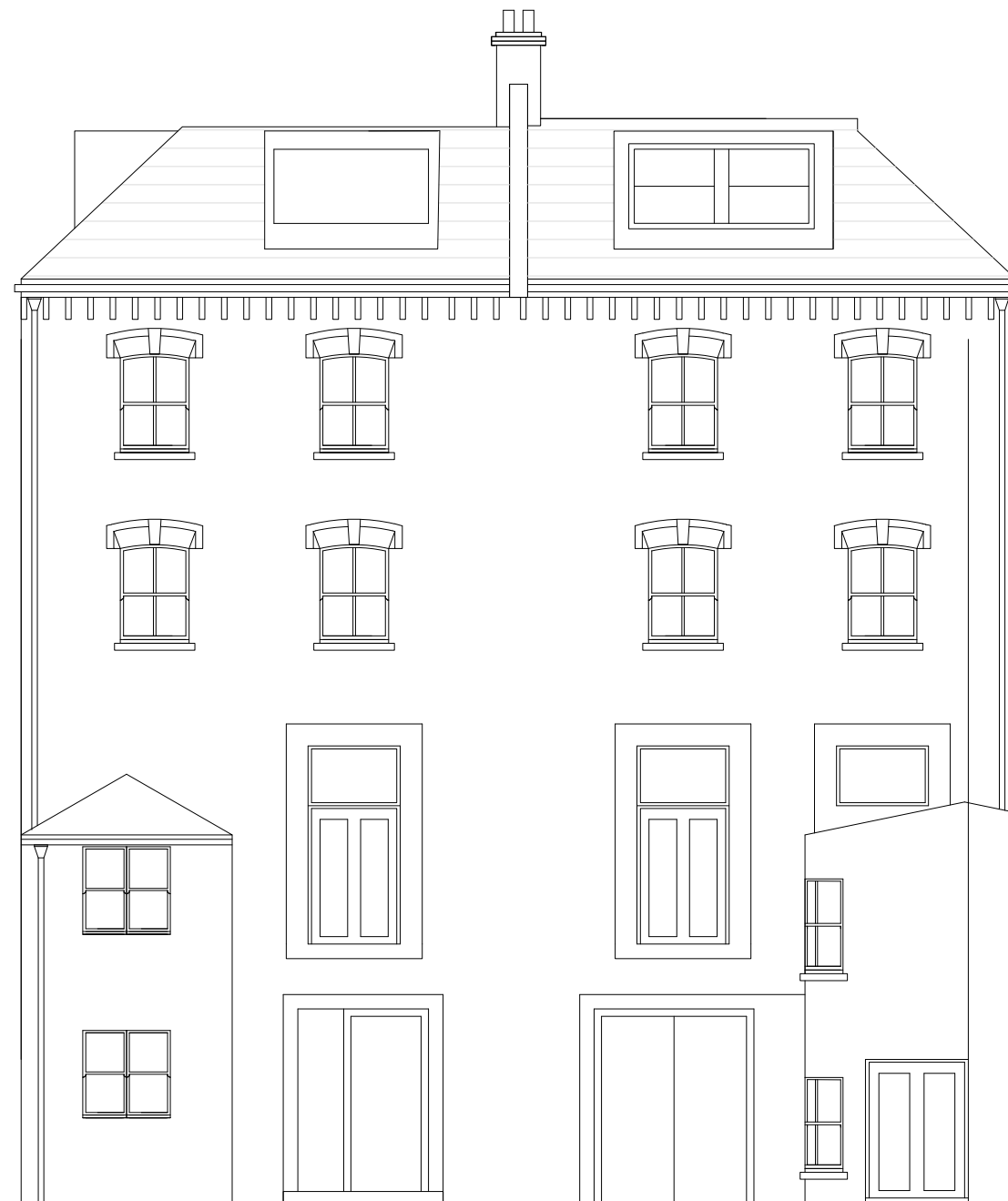

74 Parkhill Road

EXISTING REAR ELEVATION

SCALE - 1:100 @ A3



Issued for Planning	15/03/2018	B
Issued for Client Approval	10/02/2018	A
Revision Description	Date	Rev



LOCKSLEY
ARCHITECTS

Architect Details
Westbourne Studios, Notting Hill, London W10 5JJ
info@locksleyarchitects.com
0207 206 2727

Project **74 Parkhill Road**

Title **EXISTING ELEVATIONS**

Job No 0873	Drg No 120	Revision B
-----------------------	----------------------	----------------------

GENERAL NOTES:

This drawing remains the property of Locksley Architects Ltd, reproduction shall only be allowed with written permission.

This drawing is not to be scaled for construction purposes, use written dimensions only. Any discrepancies to be reported to the architect. All dimensions to be checked on site. The contractor is responsible for all dimensions and setting out of the work on site. The contractor must ensure that all elements of the work comply with current building regulations.

PROJECT NOTES:

Survey not provided by client and Locksley Architects Ltd do not accept responsibility for any discrepancies

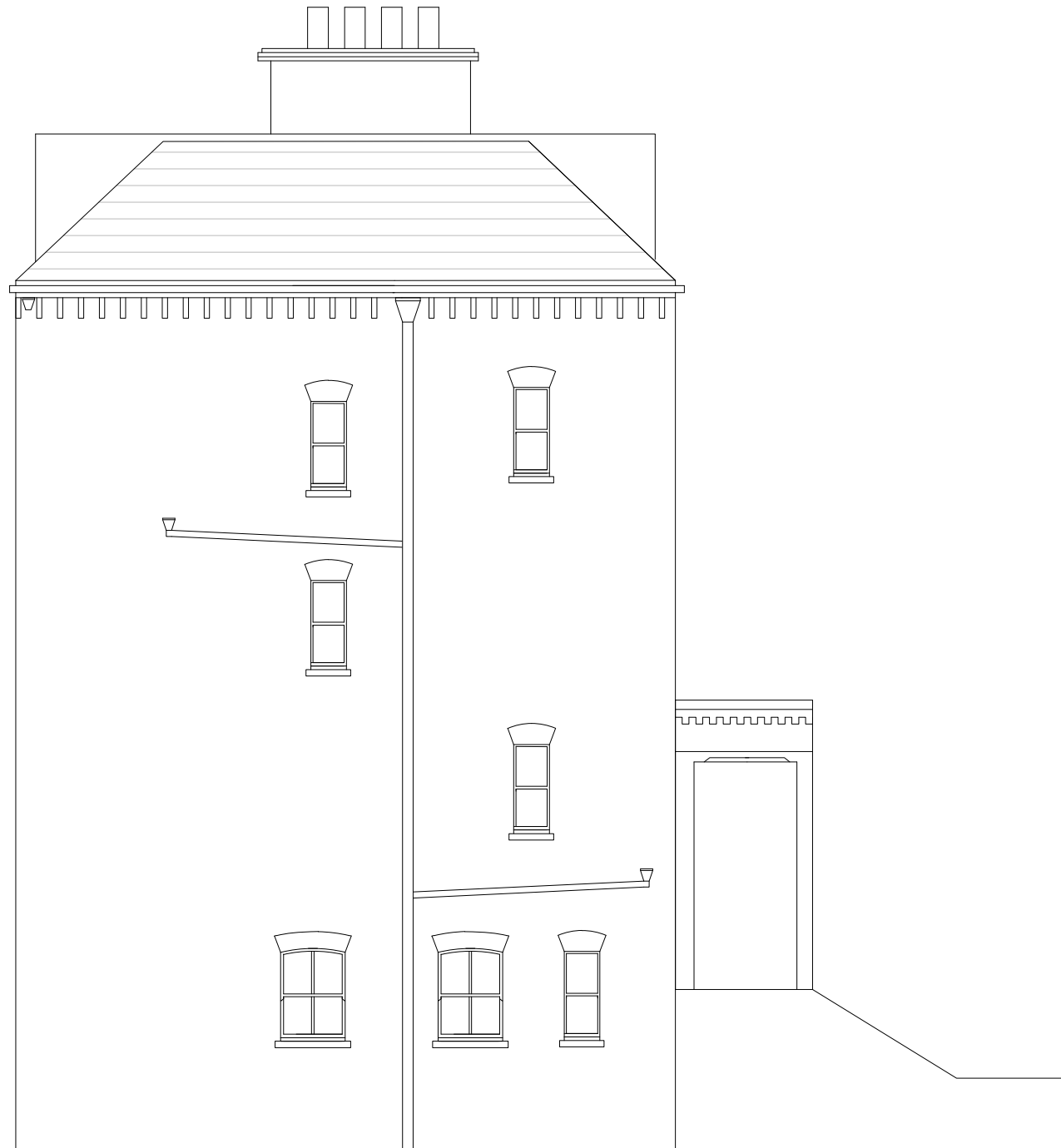

EXISTING SIDE ELEVATION

SCALE - 1:100 @ A3

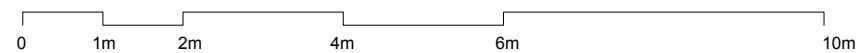

Issued for Planning	15/03/2018	B
Issued for Client Approval	10/02/2018	A

Revision Description	Date	Rev
----------------------	------	-----

		
LOCKSLEY ARCHITECTS		
Architect Details Westbourne Studios, Notting Hill, London W10 5JJ info@locksleyarchitects.com 0207 206 2727		
Project 74 Parkhill Road		
Title EXISTING ELEVATIONS		
Job No 0873	Drg No 121	Revision B

GENERAL NOTES:

This drawing remains the property of Locksley Architects Ltd, reproduction shall only be allowed with written permission.

This drawing is not to be scaled for construction purposes, use written dimensions only. Any discrepancies to be reported to the architect. All dimensions to be checked on site. The contractor is responsible for all dimensions and setting out of the work on site. The contractor must ensure that all elements of the work comply with current building regulations.

PROJECT NOTES:

Survey not provided by client and Locksley Architects Ltd do not accept responsibility for any discrepancies

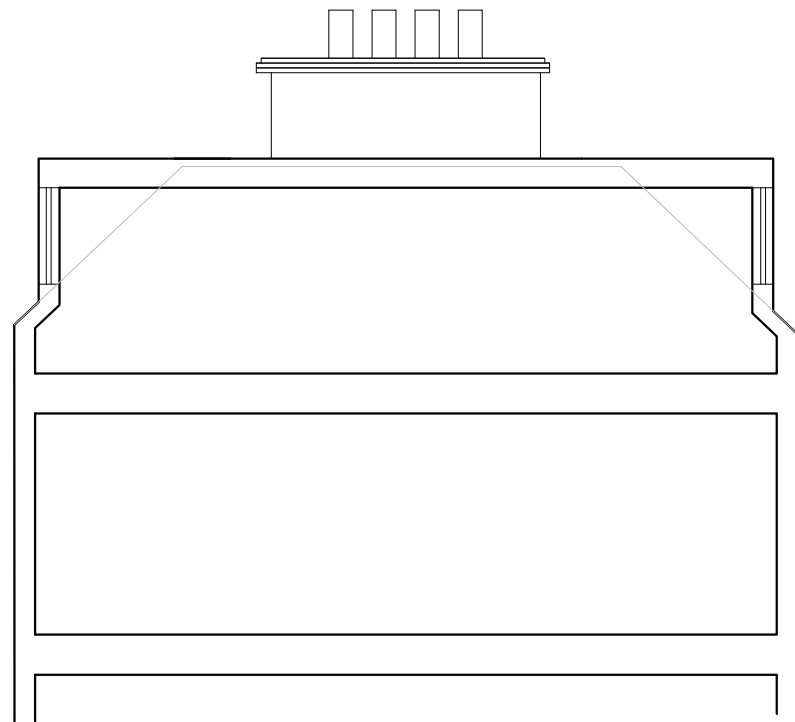

LONG SECTION

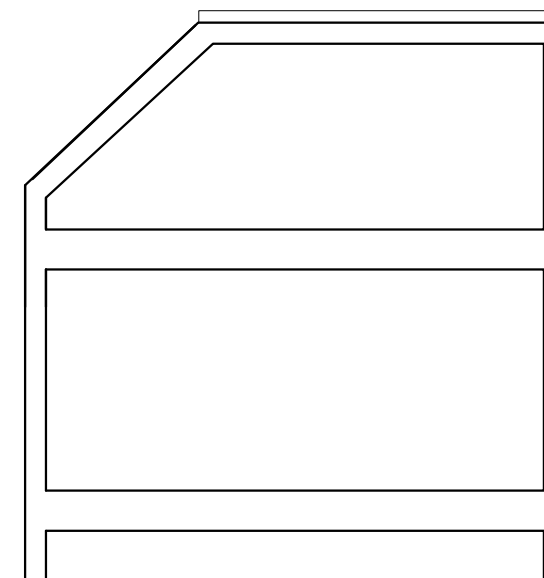

SHORT SECTION

SCALE - 1:100 @ A3

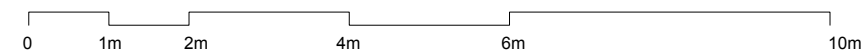

Revision Description	Date	Rev
Issued for Planning	15/03/2018	B
Issued for Client Approval	10/02/2018	A



LOCKSLEY
ARCHITECTS

Architect Details

Westbourne Studios, Notting Hill, London W10 5JJ
info@locksleyarchitects.com
0207 206 2727

Project

74 Parkhill Road

Title

EXISTING SECTION

Job No

0873

Drg No

130

Revision

B

GENERAL NOTES:

This drawing remains the property of Locksley Architects Ltd, reproduction shall only be allowed with written permission.

This drawing is not to be scaled for construction purposes, use written dimensions only. Any discrepancies to be reported to the architect. All dimensions to be checked on site. The contractor is responsible for all dimensions and setting out of the work on site. The contractor must ensure that all elements of the work comply with current building regulations.

PROJECT NOTES:

Survey provided by client and Locksley Architects Ltd do not accept responsibility for any discrepancies

New mansard roof extension to create an additional one bedroom flat

Existing pitch to be retained

New dormer with flat roof

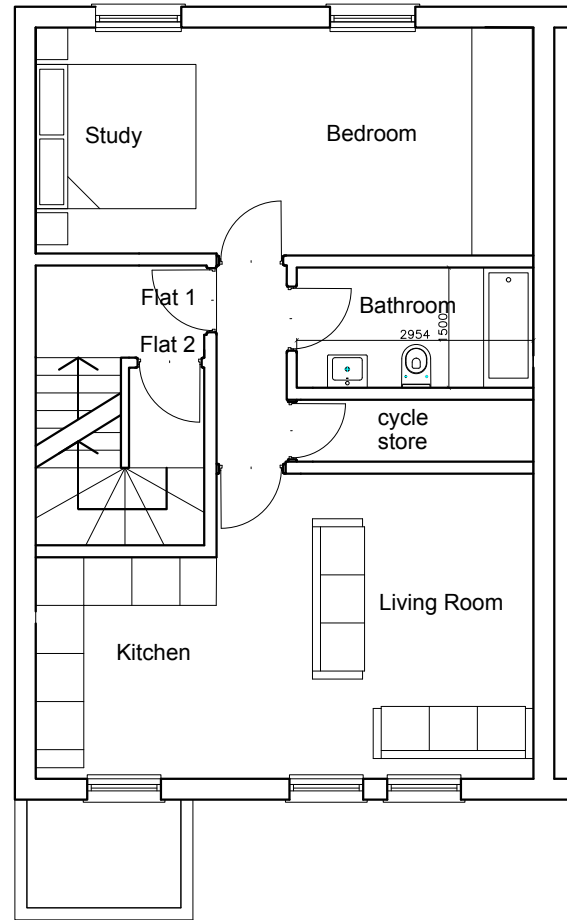

PROPOSED SECOND FLOOR PLAN
1 BEDROOM FLAT
50m²

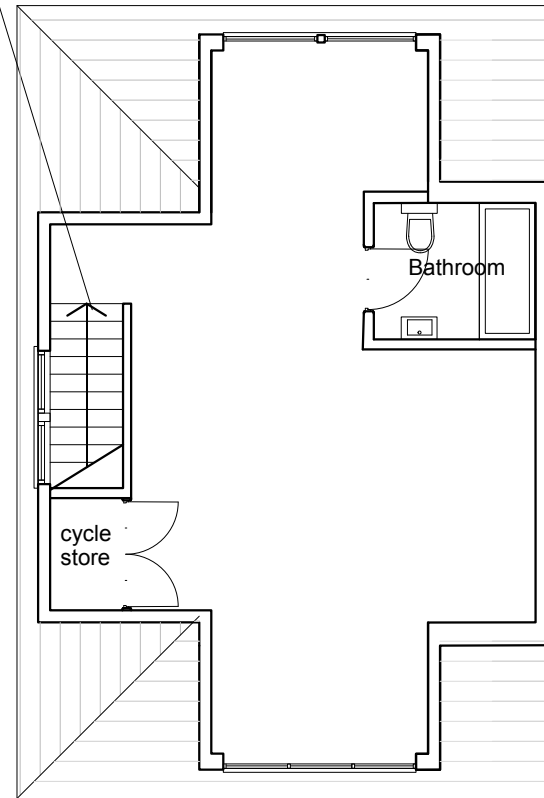

PROPOSED THIRD FLOOR PLAN
1 BEDROOM FLAT
50m²

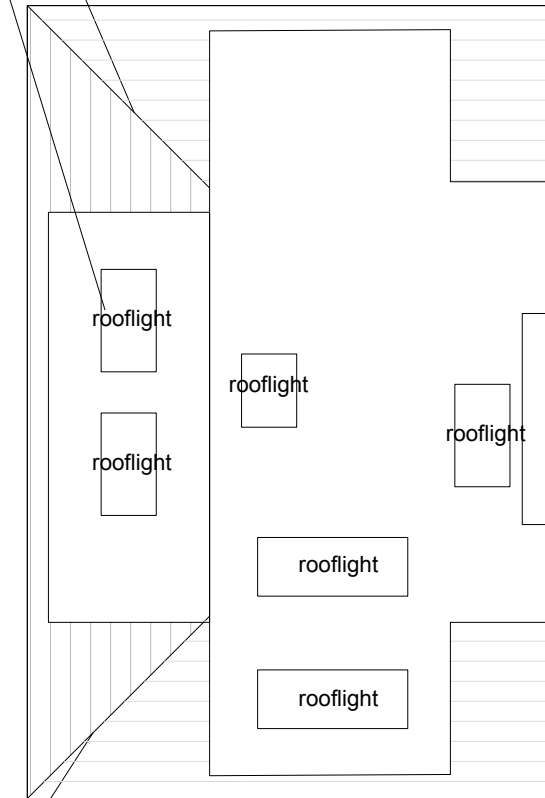

PROPOSED ROOF PLAN

Existing pitch to be retained

SURVEY DRAWING SUPPLIED BY OTHERS

SCALE - 1:100 @ A3



Issued for Planning	15/03/2018	B
Issued for Client Approval	10/02/2018	A
Revision Description	Date	Rev



LOCKSLEY
ARCHITECTS

Architect Details
Westbourne Studios, Notting Hill, London W10 5JJ
info@locksleyarchitects.com
0207 206 2727

Project
74 Parkhill Road

Title
PROPOSED PLANS

Job No 0873	Drg No 210	Revision B
-----------------------	----------------------	----------------------

GENERAL NOTES:

This drawing remains the property of Locksley Architects Ltd, reproduction shall only be allowed with written permission.

This drawing is not to be scaled for construction purposes, use written dimensions only. Any discrepancies to be reported to the architect. All dimensions to be checked on site. The contractor is responsible for all dimensions and setting out of the work on site. The contractor must ensure that all elements of the work comply with current building regulations.

PROJECT NOTES:

Survey not provided by client and Locksley Architects Ltd do not accept responsibility for any discrepancies - Rear elevation estimated as no access was provided

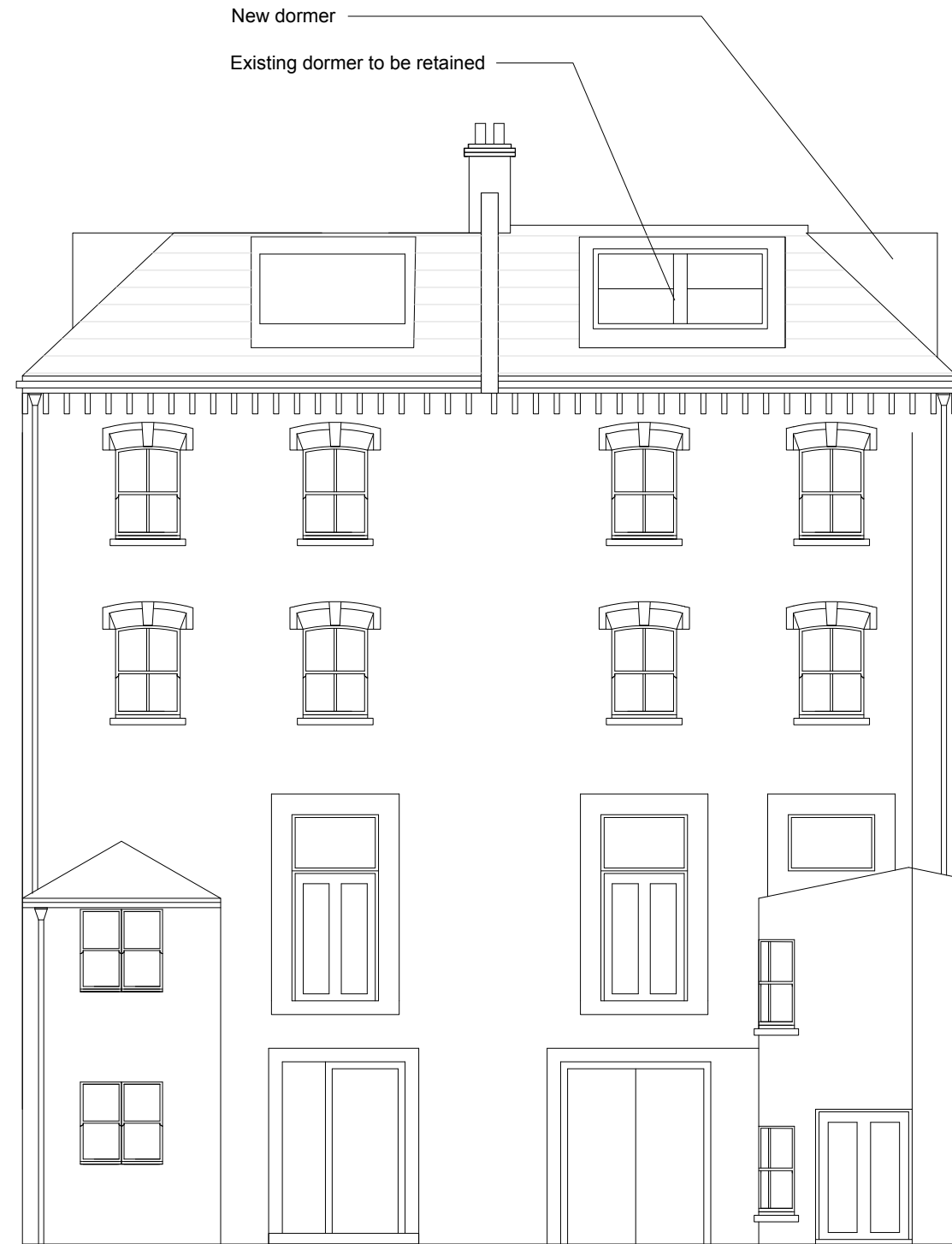

74 Parkhill Road

74 Parkhill Road

PROPOSED FRONT ELEVATION

PROPOSED REAR ELEVATION

SCALE - 1:100 @ A3



Issued for Planning	15/03/2018	B
Issued for Client Approval	10/02/2018	A
Revision Description	Date	Rev



LOCKSLEY
ARCHITECTS

Architect Details
Westbourne Studios, Notting Hill, London W10 5JJ
info@locksleyarchitects.com
0207 206 2727

Project
74 Parkhill Road

Title
PROPOSED ELEVS

Job No 0873	Drg No 220	Revision B
-----------------------	----------------------	----------------------

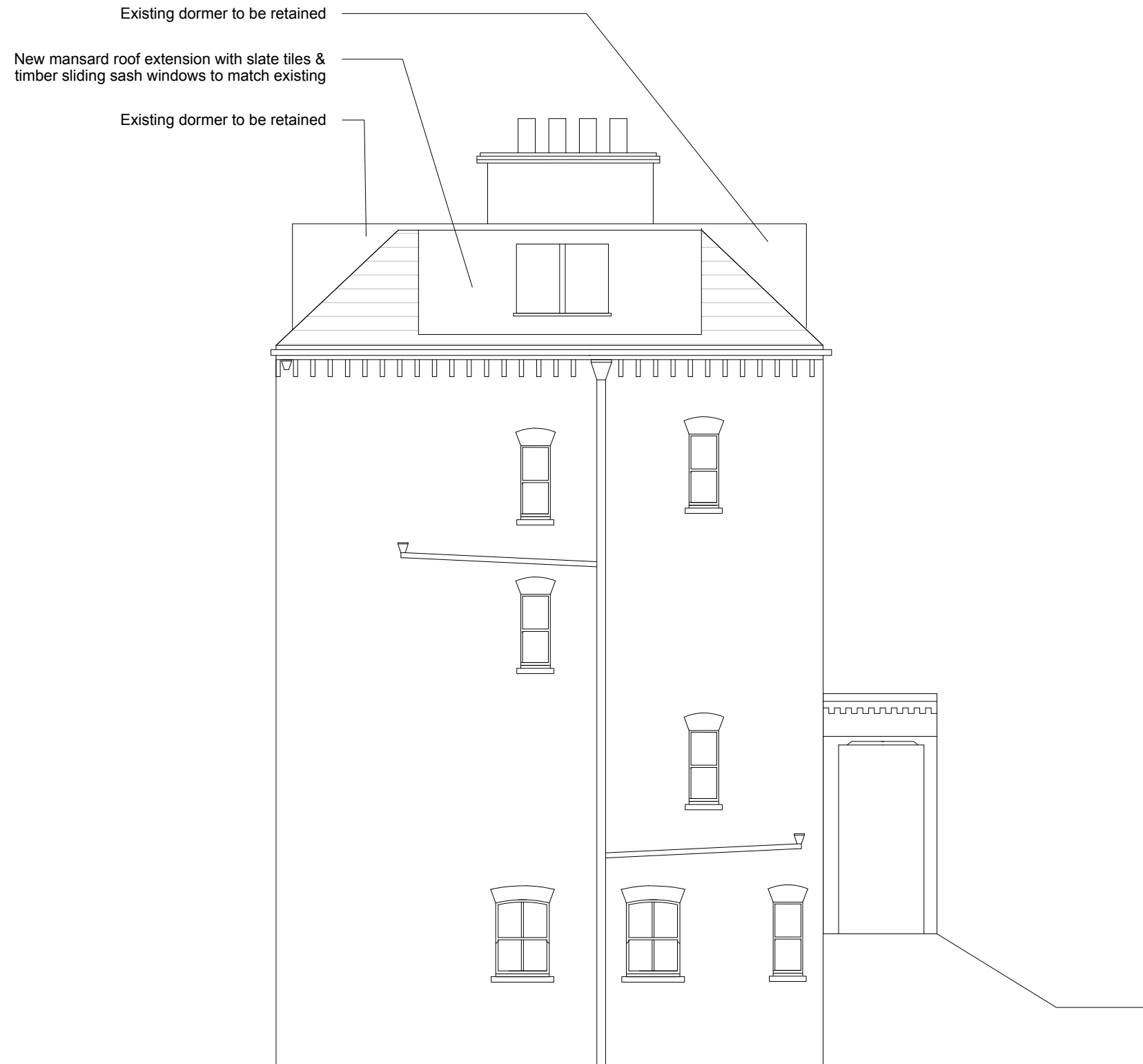

PROPOSED SIDE ELEVATION

SCALE - 1:100 @ A3

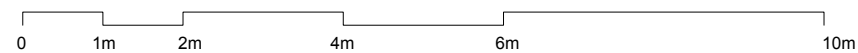

GENERAL NOTES:

This drawing remains the property of Locksley Architects Ltd, reproduction shall only be allowed with written permission.

This drawing is not to be scaled for construction purposes, use written dimensions only. Any discrepancies to be reported to the architect. All dimensions to be checked on site. The contractor is responsible for all dimensions and setting out of the work on site. The contractor must ensure that all elements of the work comply with current building regulations.

PROJECT NOTES:

Survey not provided by client and Locksley Architects Ltd do not accept responsibility for any discrepancies

Issued for Planning	15/03/2018	B
Issued for Client Approval	10/02/2018	A
Revision Description	Date	Rev

LOCKSLEY
ARCHITECTS

Architect Details
Westbourne Studios, Notting Hill, London W10 5JJ
info@locksleyarchitects.com
0207 206 2727

Project
74 Parkhill Road

Title
PROPOSED ELEVS

Job No	Drg No	Revision
0873	221	B

GENERAL NOTES:

This drawing remains the property of Locksley Architects Ltd, reproduction shall only be allowed with written permission.

This drawing is not to be scaled for construction purposes, use written dimensions only. Any discrepancies to be reported to the architect. All dimensions to be checked on site. The contractor is responsible for all dimensions and setting out of the work on site. The contractor must ensure that all elements of the work comply with current building regulations.

PROJECT NOTES:

Survey not provided by client and Locksley Architects Ltd do not accept responsibility for any discrepancies

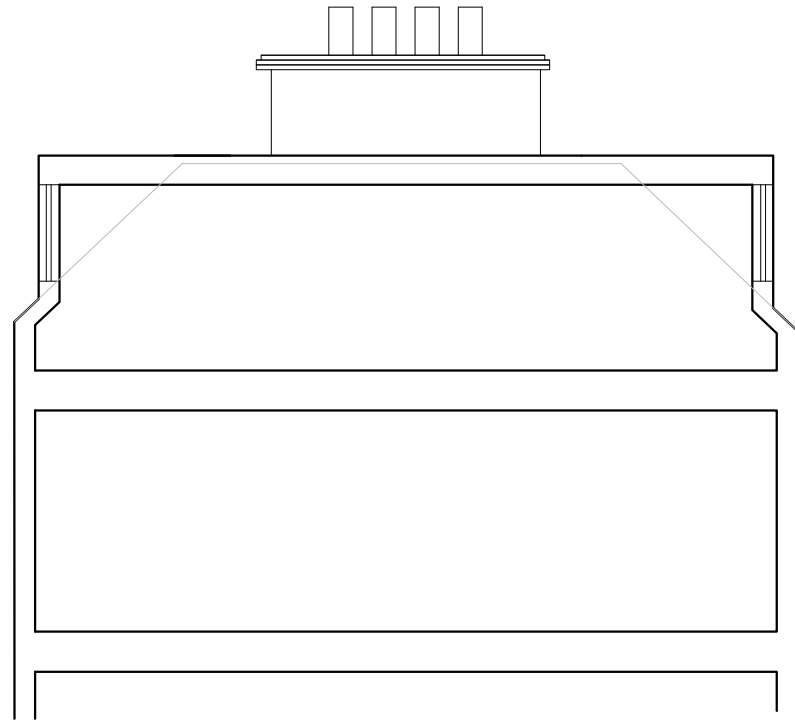

LONG SECTION

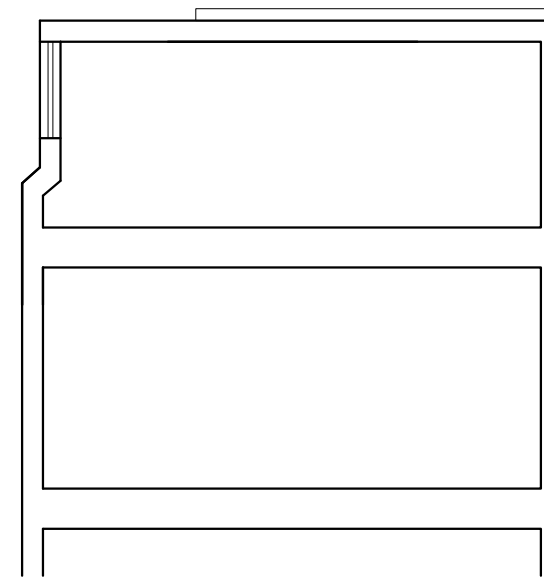

SHORT SECTION

SCALE - 1:100 @ A3

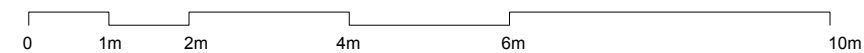

Revision Description	Date	Rev
Issued for Planning	15/03/2018	B
Issued for Client Approval	10/02/2018	A



Architect Details
Westbourne Studios, Notting Hill, London W10 5JJ
info@locksleyarchitects.com
0207 206 2727

Project
74 Parkhill Road

Title
PROPOSED SECTION

Job No	Drg No	Revision
0873	230	B