

700_102
10 **CORNICE TYPE J**
Existing cornice profile
r3.02
New cornice to match existing profile
r3.03, r3.04 scale 1:2

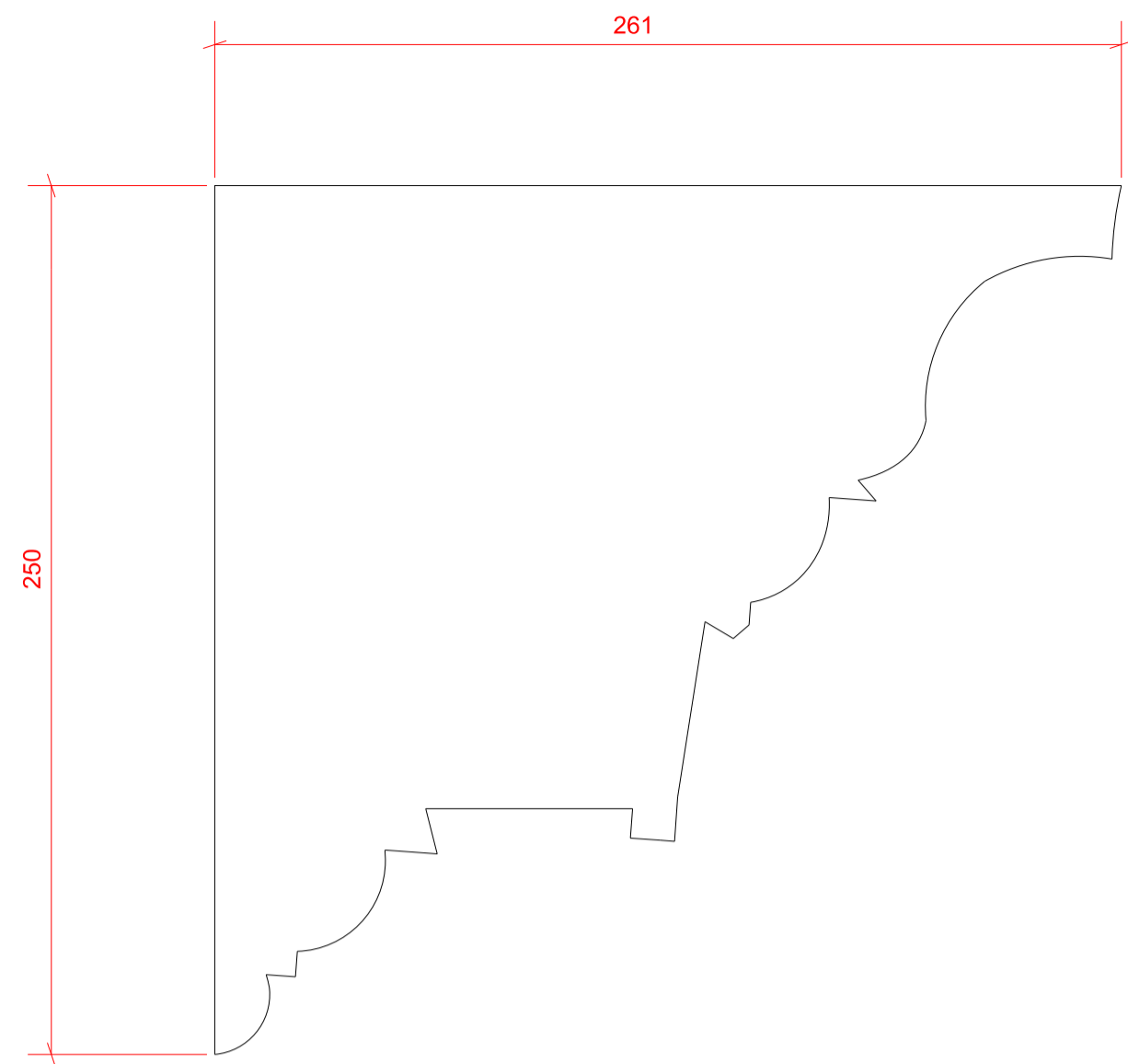

700_102
07 **CORNICE TYPE G**
Existing cornice profile
r2.02, r2.03, r2.04
New cornice to match existing profile
r2.02, r2.03, r2.04 scale 1:2

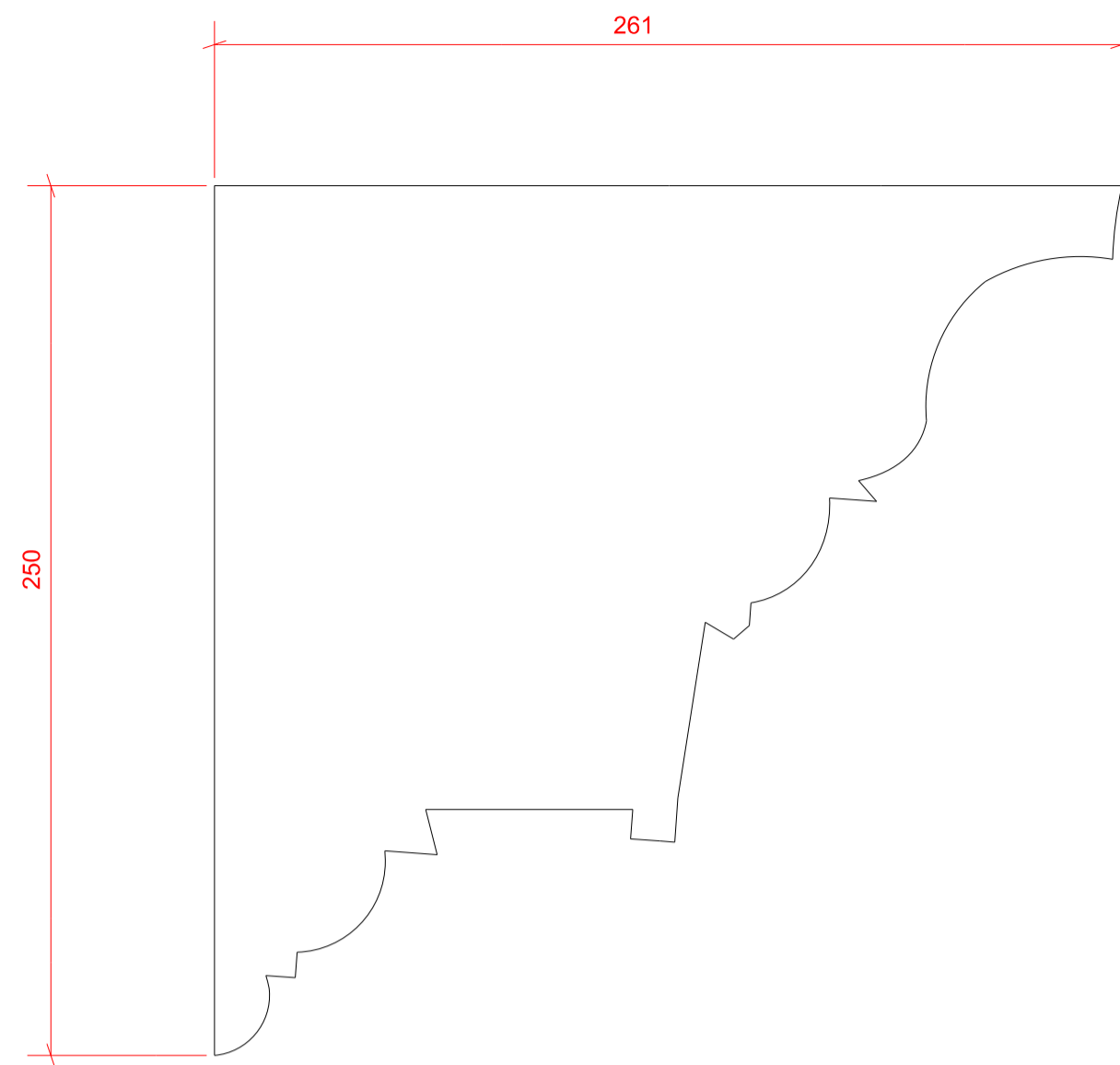

700_102
04 **CORNICE TYPE D**
New cornice to match existing second floor profile
r1.02, scale 1:2

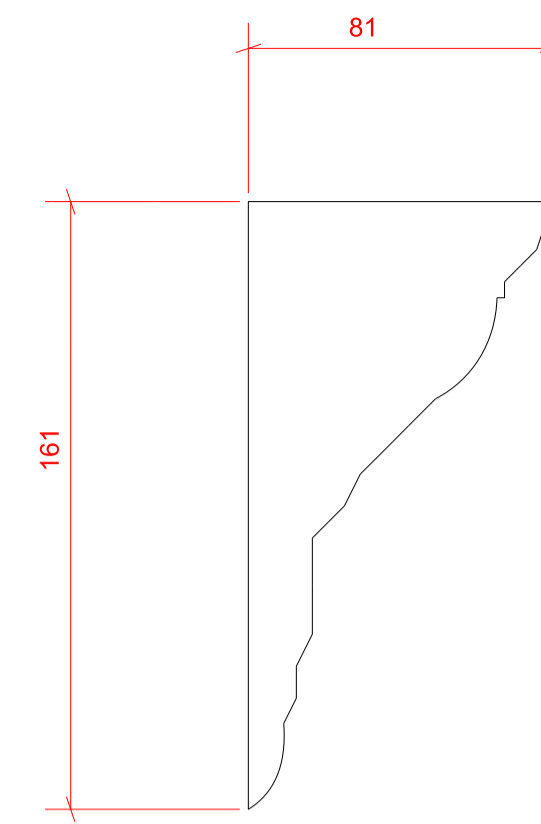

700_102
01 **CORNICE TYPE A**
Existing cornice profile
rG.02, scale 1:2

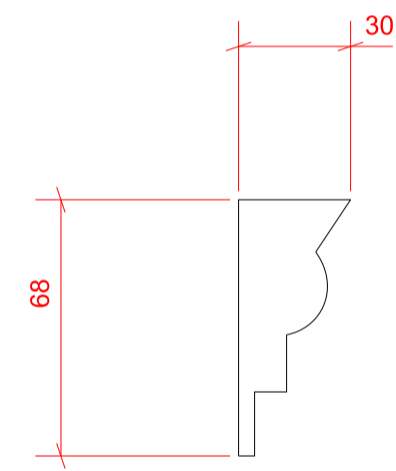

700_102
11 **CORNICE TYPE K**
New cornice to match existing profile
r3.01 scale 1:2

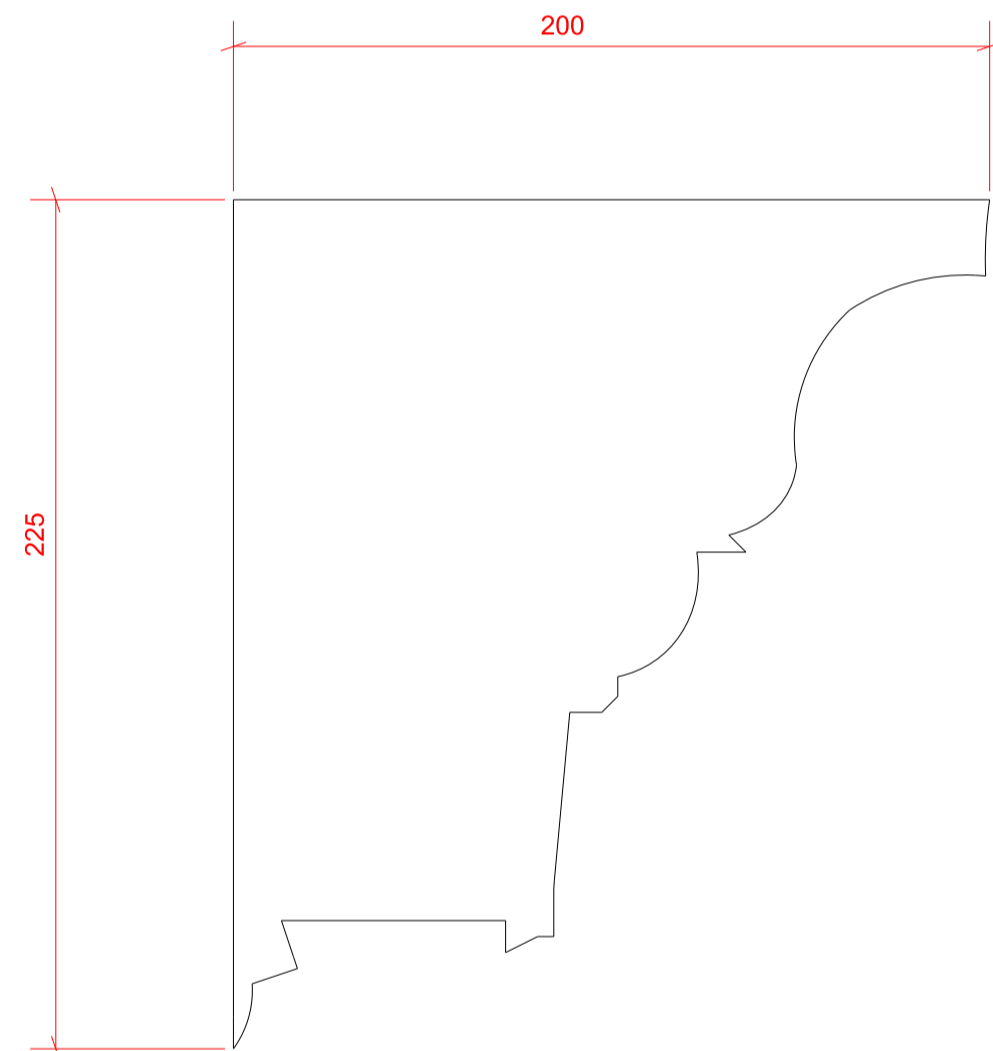

700_102
08 **CORNICE TYPE H**
Existing cornice profile
r2.01, r2.05
New cornice to match existing profile
r2.01 scale 1:2

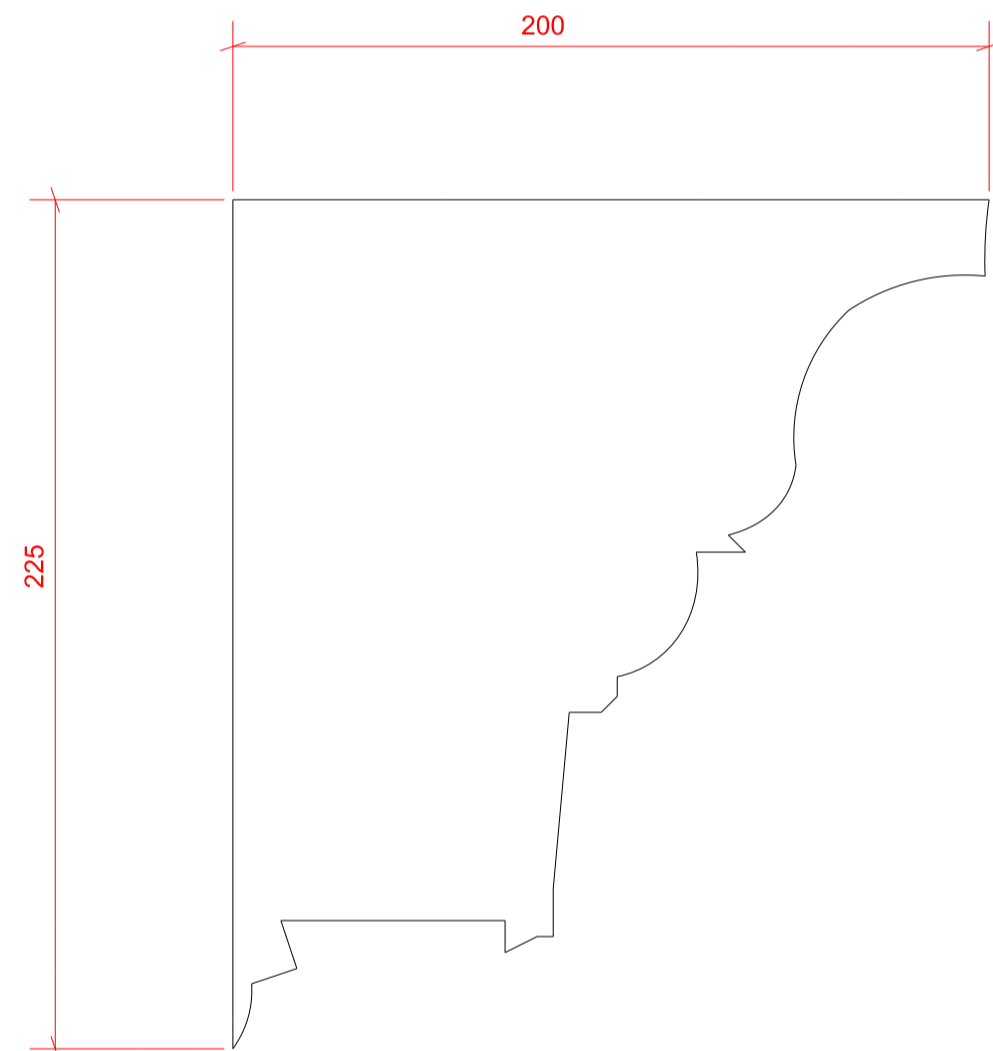

700_102
05 **CORNICE TYPE E**
New cornice to match existing second floor profile
r1.01, r1.03 scale 1:2

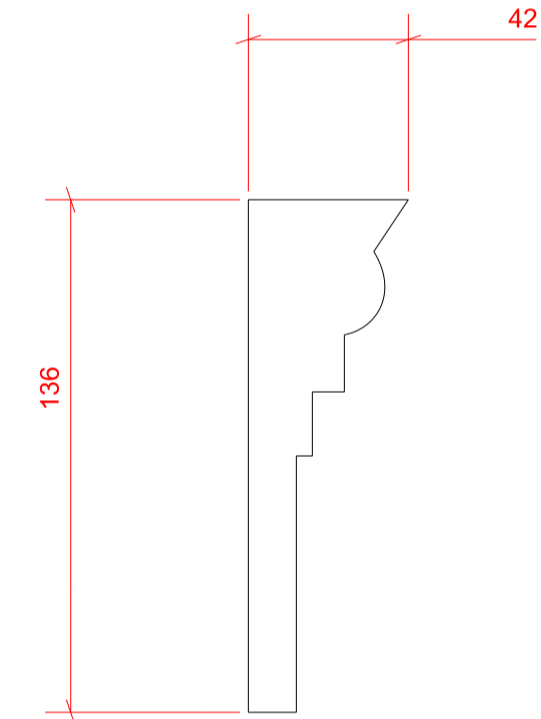

700_102
07 **CORNICE TYPE B**
Existing cornice profile
rG.01, rG.03, scale 1:2

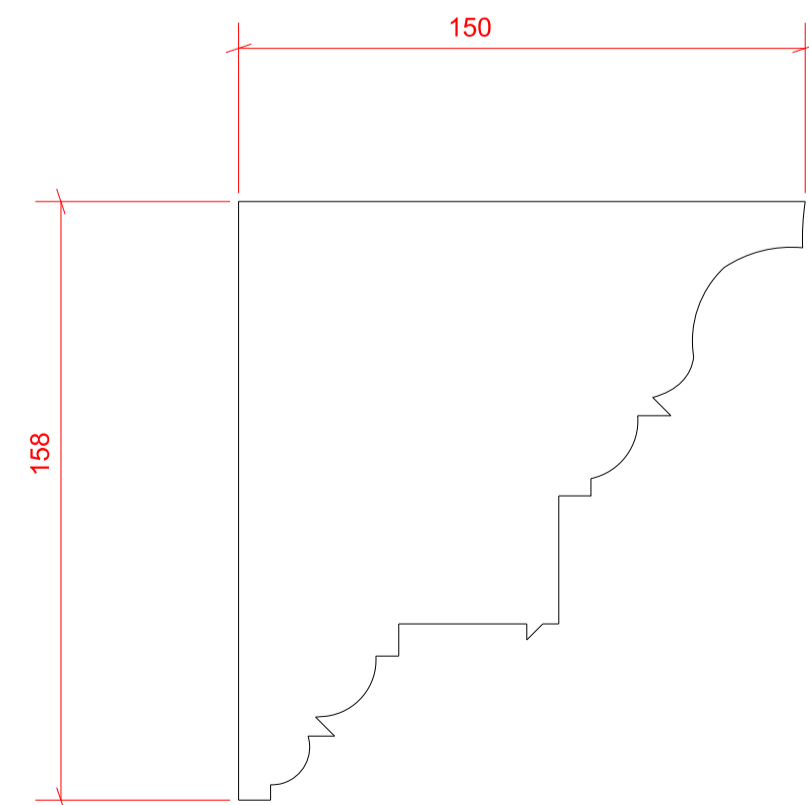

700_102
12 **CORNICE TYPE L**
New cornice to match existing second floor profile
r3.06 scale 1:2

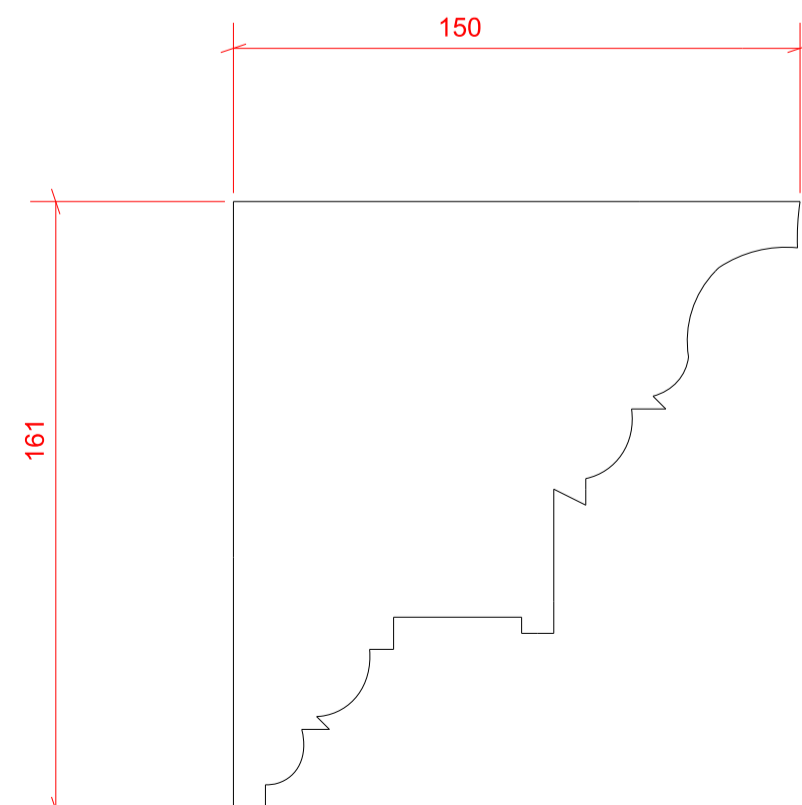

700_102
09 **CORNICE TYPE I**
Existing cornice profile
r2.06, scale 1:2

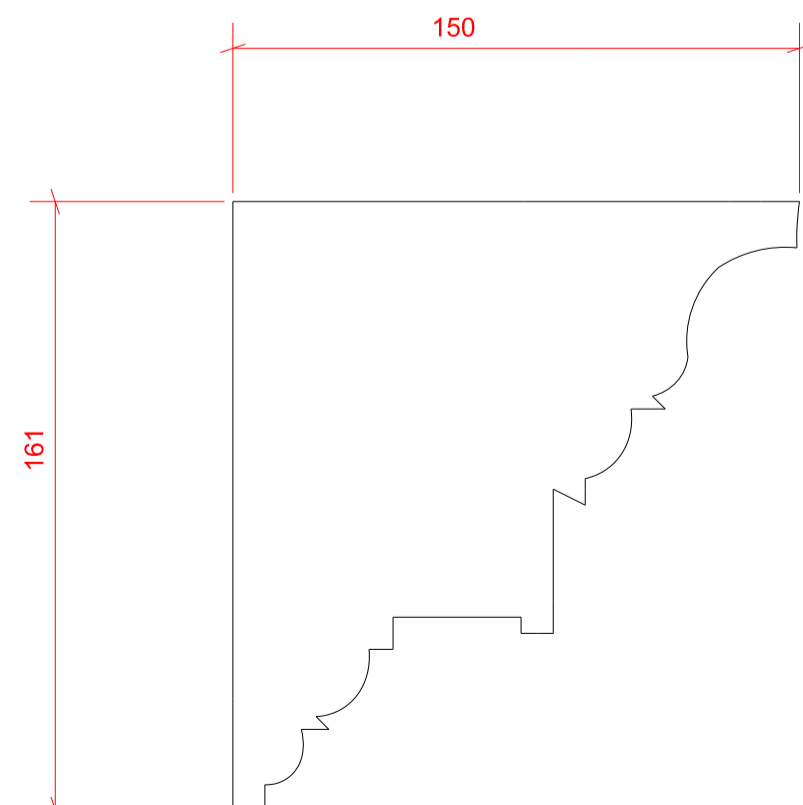

700_102
06 **CORNICE TYPE F**
New cornice to match existing second floor profile
r1.04 scale 1:2

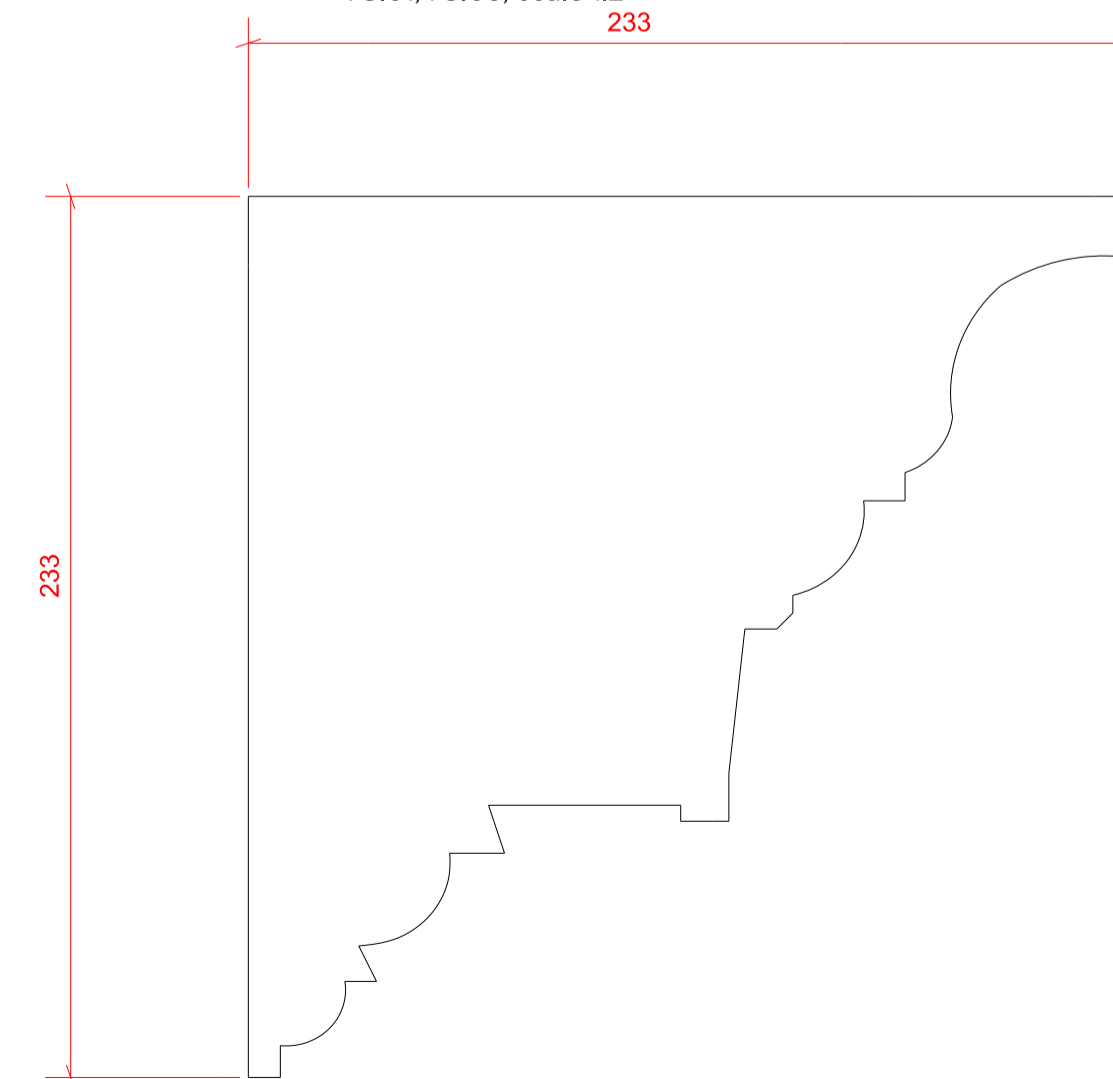

700_102
03 **CORNICE TYPE C**
Existing cornice profile
rG.05, scale 1:2

CONSTRUCTION

Project No.	17103	
Client	GFZ Investments Ltd.	
Date	January 2018	
Scale	1:2 @ A1	
Project	34 Great James Street	
Drawing Title	Proposed Cornice Types	
Drawing No.	700_102	
Rev.	-	
Drawn	Approved	Signed
	MW	



66 - 68 Margaret Street W1W 8SR T. 020 7580 9336 www.mwa.co.uk
Copyright Marek Wojciechowski Architects. No implied license exists. This drawing should not be used to calculate areas for the purposes of valuation. All dimensions to be checked on site by the contractor and such dimensions to be their responsibility. Do not scale drawings. All work must comply with relevant British Standards and Building Regulations requirements. Drawing errors and omissions to be reported to the architect.