



LOCKSLEY  
ARCHITECTS

WASTE MANAGEMENT STRATEGY

at

74 PARKHIL ROAD, LONDON

## Proposal

Dedicated internal recyclable waste storage will be provided within each dwelling in a dedicated space, to allow for segregation and storage of waste prior to transfer to the external bin stores

These internal waste stores will be provided in accordance with the requirements laid out within the Code for Sustainable Homes, against which each of the dwellings are being assessed. These design requirements are as follows:

- Three identifiably separate bins.
- Total capacity of no less than 30 litres.
- No bin smaller than seven litres.

These internal bins will be provided in a dedicated space within each of the dwellings in a location that is inoffensive and does not interfere with the operation of the kitchen. These requirements are exclusive of residual waste containers, therefore it is recommended that in a dedicated place in all residencies:

- A minimum of one 30 litre residual waste container is provided
- A co-ordinated kitchen or utility room mounted bin system meeting all of the above requirements is the proposed approach in all residencies

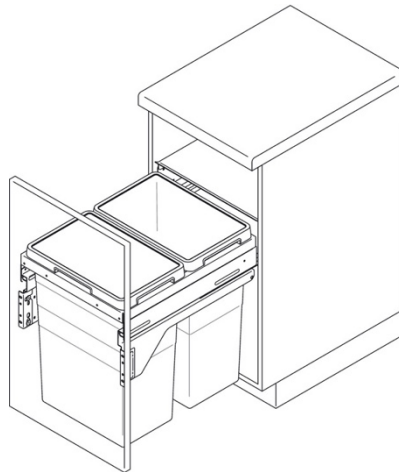

Image 01 – Example of typical waste storage unit