

Appendix A

Preliminary Form SD Structural Drawings

Drawing No.	Drawing Title	Revision
L(00)01	Existing Lower Ground Floor Plan	P1
L(00)02	Existing Ground Floor Plan	P1
L(17)01	Proposed Plant Level Plan	P2
L(17)02	Proposed Basement Level Plan	P3
L(23)01	Proposed Lower Ground Floor Plan	P2
L(23)02	Proposed Ground Floor Plan	P4
L(23)03	Proposed First Floor Plan	P2
L(23)04	Proposed Second Floor Plan	P3
L(23)05	Proposed Roof Plan	P2
A(28)01	Proposed Cross Sections A-A & B-B	P3
A(28)02	Proposed Cross Sections C-C & D-D	P3
A(28)03	Proposed Cross Sections E-E & F-F	P3
A(23)01	Proposed Sections & Details	P2
A(23)02	Proposed Upper Floor Sections & Details	P1
A(28)50	Proposed Steel Roof Truss – Sheet 1	P2
A(28)51	Proposed Steel Roof Truss – Sheet 2	P2
A(28)52	Proposed Steel Roof Truss – Sheet 3	P3
A(28)53	Proposed Steel Roof Truss – Sheet 4	P2

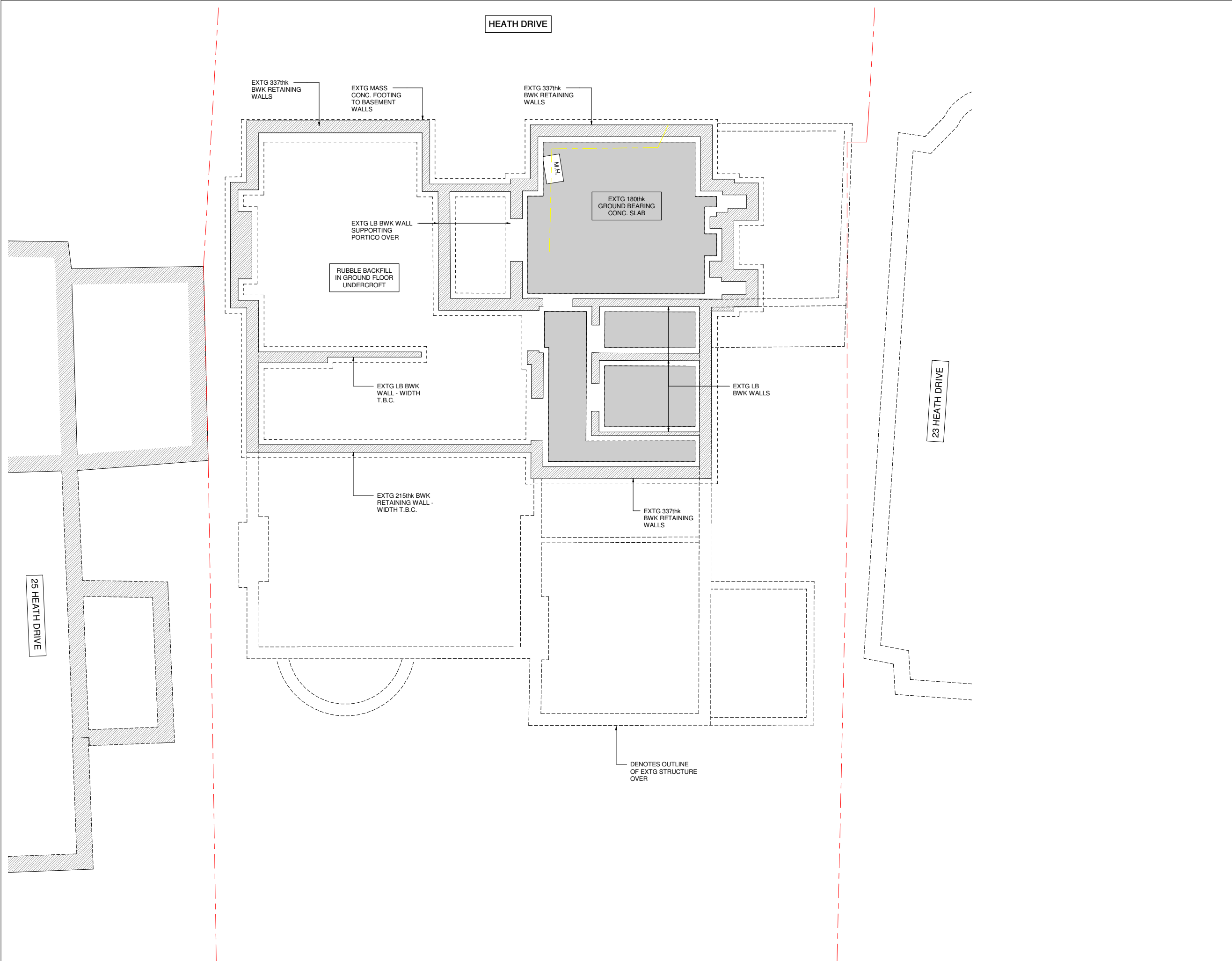

Notes
 THIS DRAWING IS COPYRIGHT OF FORM.
 DO NOT SCALE FROM THIS DRAWING WORK ONLY TO FIGURED DIMENSIONS.
 THE CONTRACTOR IS TO VERIFY ALL DIMENSIONS ON SITE BEFORE COMMENCING WORK. ALL ERRORS AND OMISSIONS ARE TO BE REPORTED TO THE ENGINEER.
 THIS DRAWING IS TO BE READ IN CONJUNCTION WITH ALL RELEVANT ARCHITECTS, SERVICES ENGINEERS AND ENGINEERS DRAWINGS AND SPECIFICATIONS.

KEY	
	EXISTING WALL
	NEW 20N/mm² BRICKWORK IN DESIGNATION (ii) MORTAR.
	NEW 7N/mm² MEDIUM DENSE BLOCKWORK IN DESIGNATION (ii) MORTAR.
	NEW LOADBEARING TIMBER STUD PARTITION (50x100 C24 STUDS AT 400c/c).
	NEW NON LOAD BEARING PARTITION.
	LOAD BEARING WALL UNDER.
	NEW BRICKWORK TO BE FULLY TOOTHED IN AND PACKED UP TO EXTG BRICKWORK
	STAINLESS STEEL WALL EXTENSION PROFILES.
ALL MASONRY BELOW DPC LEVEL TO BE FROST RESISTANT AND IN DESIGNATION (i) MORTAR.	
LEGEND	
	NEW BEAM UNDER.
	DOUBLED TIMBERS TRIMMING OPENINGS/ UNDER PARTITIONS.
	DENOTES SPAN OF NEW 50x200 C24 TIMBER JOISTS AT 400c/c U.N.O.
	DENOTES SPAN OF NEW 50x150 C24 TIMBER RAFTERS AT 400c/c U.N.O.
	DENOTES SPAN OF NEW CONCRETE SLAB
	DENOTES SPAN OF NEW 150mm DEEP BEAM & BLOCK FLOOR.
	DENOTES SPAN OF EXISTING TIMBER JOISTS.

Rev.	Date	Amendment	Drawn	Chkd
P1	13.12.17	ISSUED FOR PLANNING	P.E	C.M

Drawing Status **PRELIMINARY**

Form

Job Title
**24 HEATH DRIVE
 LONDON
 NW3 7SB**

Drawing Title
EXISTING LOWER GROUND FLOOR & UNDERCROFT PLAN

Form Structural Design Ltd 77 St John Street London EC1M 4NN
 T:020 7253 2893 E:studio@form-sd.com W:www.form-sd.com

Date	Scale	Drawn	Checked
DEC 17	As indicated	P.E	C.M
Job No.	Drawing No.	Revision	
162637	L(00)01	P1	

EXISTING LOWER GROUND FLOOR
 1 : 50

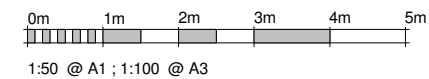

HEATH DRIVE

HATCHED AREA DENOTES EXTENT OF EXISTING BASEMENT UNDER

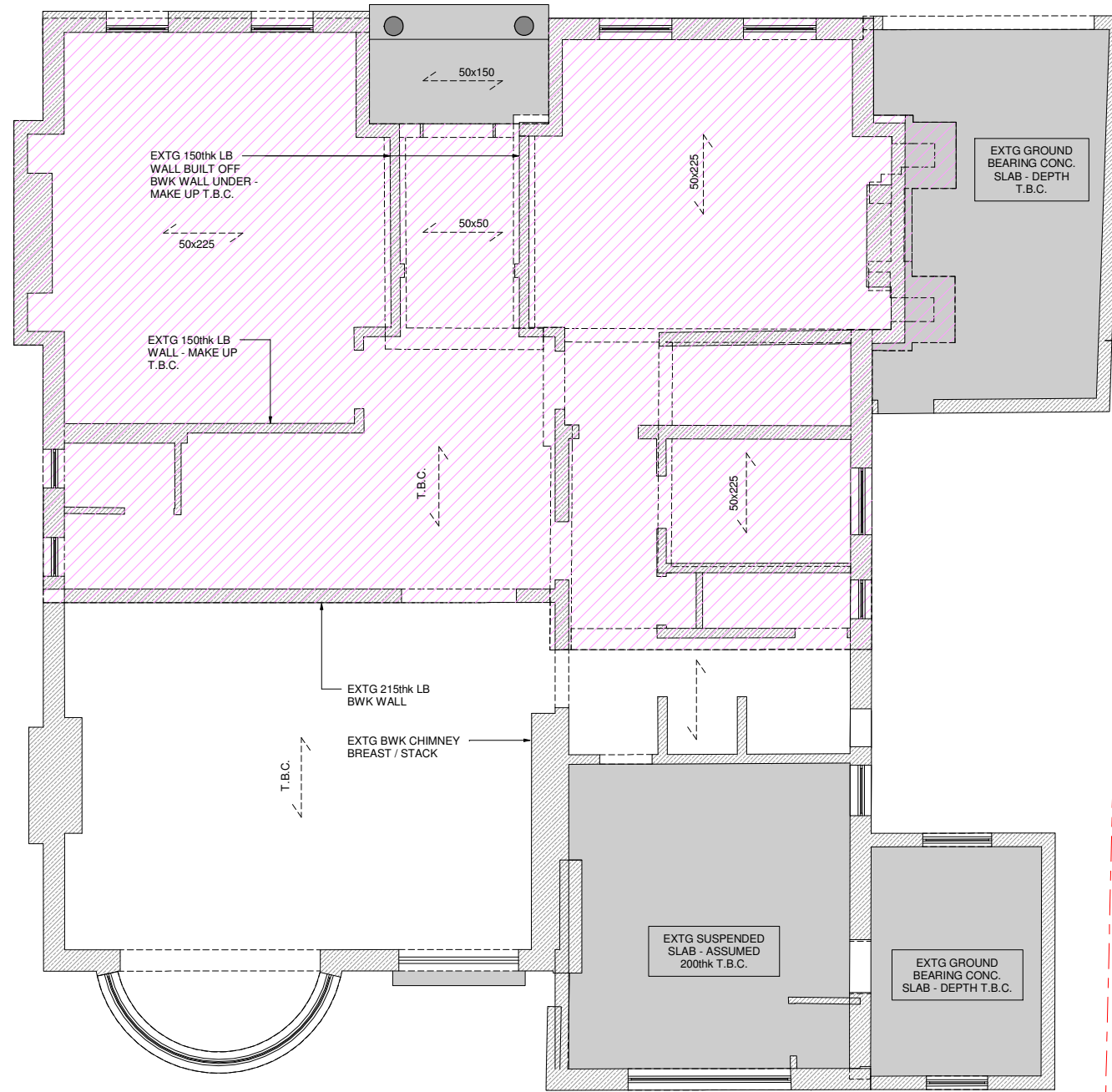

25 HEATH DRIVE

23 HEATH DRIVE

Notes

THIS DRAWING IS COPYRIGHT OF FORM.

DO NOT SCALE FROM THIS DRAWING WORK ONLY TO FIGURED DIMENSIONS.

THE CONTRACTOR IS TO VERIFY ALL DIMENSIONS ON SITE BEFORE COMMENCING WORK. ALL ERRORS AND OMISSIONS ARE TO BE REPORTED TO THE ENGINEER.

THIS DRAWING IS TO BE READ IN CONJUNCTION WITH ALL RELEVANT ARCHITECTS, SERVICES ENGINEERS AND ENGINEERS DRAWINGS AND SPECIFICATIONS.

KEY	
EXISTING WALL	
NEW 20N/mm ² BRICKWORK IN DESIGNATION (ii) MORTAR.	
NEW 7N/mm ² MEDIUM DENSE BLOCKWORK IN DESIGNATION (ii) MORTAR.	
NEW LOADBEARING TIMBER STUD PARTITION (50x100 C24 STUDS AT 400c/c).	
NEW NON LOAD BEARING PARTITION.	
LOAD BEARING WALL UNDER.	
NEW BRICKWORK TO BE FULLY TOOTHED IN AND PACKED UP TO EXTG BRICKWORK	
W STAINLESS STEEL WALL EXTENSION PROFILES.	
ALL MASONRY BELOW DPC LEVEL TO BE FROST RESISTANT AND IN DESIGNATION (i) MORTAR.	
LEGEND	
NEW BEAM UNDER.	
DOUBLED TIMBERS TRIMMING OPENINGS/ UNDER PARTITIONS.	
DENOTES SPAN OF NEW 50x200 C24 TIMBER JOISTS AT 400c/c U.N.O.	
DENOTES SPAN OF NEW 50x150 C24 TIMBER RAFTERS AT 400c/c U.N.O.	
DENOTES SPAN OF NEW CONCRETE SLAB	
DENOTES SPAN OF NEW 150mm DEEP BEAM & BLOCK FLOOR.	
DENOTES SPAN OF EXISTING TIMBER JOISTS.	

P1	13.12.17	ISSUED FOR PLANNING	P.E	C.M
Rev.	Date	Amendment	Drawn	Chkd

Drawing Status **PRELIMINARY**

Form

Job Title
**24 HEATH DRIVE
LONDON
NW3 7SB**

Drawing Title
EXISTING GROUND FLOOR PLAN

Form Structural Design Ltd 77 St John Street London EC1M 4NN
T:020 7253 2893 E:studio@form-sd.com W:www.form-sd.com

Date	Scale	Drawn	Checked
DEC 17	As indicated	P.E	C.M
Job No.	Drawing No.	Revision	
162637	L(00)02	P1	

EXISTING GROUND FLOOR PLAN

1 : 50

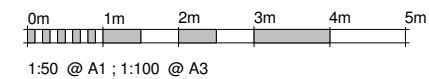

NOTE:
DRAWING TO BE READ IN CONJUNCTION WITH SUGGESTED SEQUENCE OF CONSTRUCTION - DRAWING SERIES L(30)01 - 11

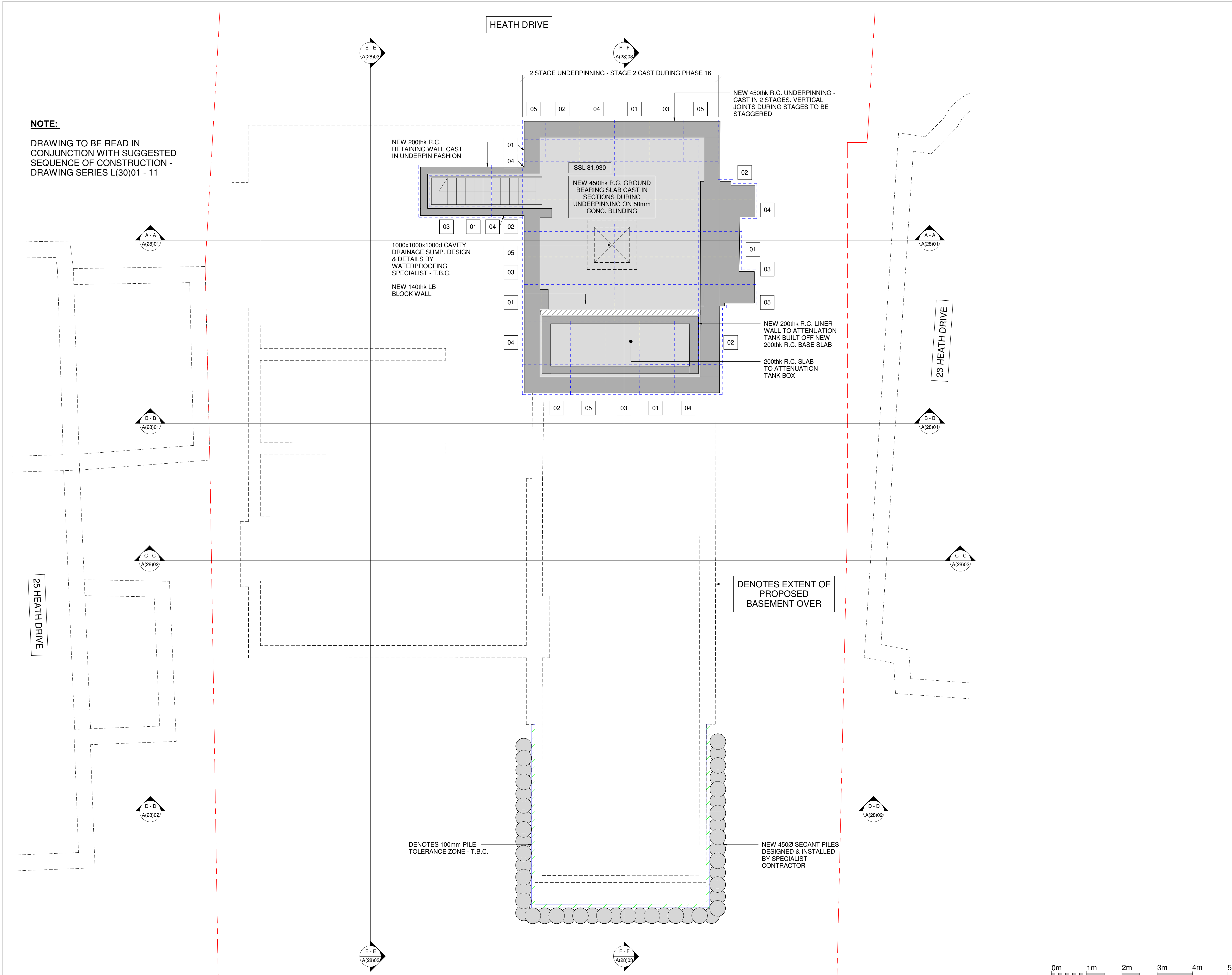

Notes
THIS DRAWING IS COPYRIGHT OF FORM.
DO NOT SCALE FROM THIS DRAWING WORK ONLY TO FIGURED DIMENSIONS.
THE CONTRACTOR IS TO VERIFY ALL DIMENSIONS ON SITE BEFORE COMMENCING WORK. ALL ERRORS AND OMISSIONS ARE TO BE REPORTED TO THE ENGINEER.
THIS DRAWING IS TO BE READ IN CONJUNCTION WITH ALL RELEVANT ARCHITECTS, SERVICES ENGINEERS AND ENGINEERS DRAWINGS AND SPECIFICATIONS.

KEY	
	EXISTING WALL
	NEW 20N/mm² BRICKWORK IN DESIGNATION (iii) MORTAR.
	NEW 7N/mm² MEDIUM DENSE BLOCKWORK IN DESIGNATION (iii) MORTAR.
	NEW LOADBEARING TIMBER STUD PARTITION (50x100 C24 STUDS AT 400c/c).
	NEW NON LOAD BEARING PARTITION.
	LOAD BEARING WALL UNDER.
	NEW BRICKWORK TO BE FULLY TOOTHED IN AND PACKED UP TO EXTG BRICKWORK
W	STAINLESS STEEL WALL EXTENSION PROFILES.
ALL MASONRY BELOW DPC LEVEL TO BE FROST RESISTANT AND IN DESIGNATION (i) MORTAR.	
LEGEND	
	NEW BEAM UNDER.
	DOUBLED TIMBERS TRIMMING OPENINGS/ UNDER PARTITIONS.
	DENOTES SPAN OF NEW 50x200 C24 TIMBER JOISTS AT 400c/c U.N.O.
	DENOTES SPAN OF NEW 50x150 C24 TIMBER RAFTERS AT 400c/c U.N.O.
	DENOTES SPAN OF NEW 75x100 C24 TIMBER RAFTERS AT 400c/c U.N.O.
	DENOTES SPAN OF NEW CONCRETE SLAB
	DENOTES SPAN OF NEW 150mm DEEP BEAM & BLOCK FLOOR.
	DENOTES SPAN OF EXISTING TIMBER CEILING JOISTS. ASSUMED 50x100 T.B.C.
	DENOTES SPAN OF EXISTING TIMBER FLOOR JOISTS. ASSUMED 50x200 T.B.C.
TT	DENOTES DOUBLE TRIMMER JOIST/RAFTERS SIZED AS PER SPAN

P2	26.01.18	ISSUED FOR PLANNING	P.E	C.M
P1	13.12.17	ISSUED FOR PLANNING	P.E	C.M
Rev.	Date	Amendment	Drawn	Chkd

Drawing Status **PRELIMINARY**

Form

Job Title
**24 HEATH DRIVE
LONDON
NW3 7SB**

Drawing Title
PROPOSED PLANT LEVEL PLAN

Form Structural Design Ltd 77 St John Street London EC1M 4NN
T:020 7253 2893 E:studio@form-sd.com W:www.form-sd.com

Date	Scale	Drawn	Checked
DEC 17	As indicated	P.E	C.M
Job No.	Drawing No.	Revision	
162637	L(17)01	P2	

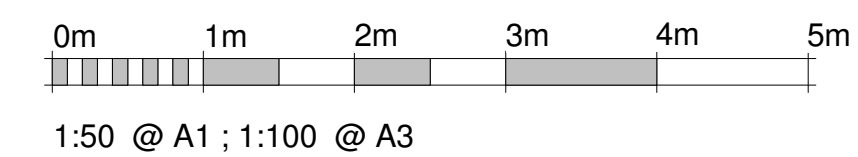

NOTE:
DRAWING TO BE READ IN CONJUNCTION WITH SUGGESTED SEQUENCE OF CONSTRUCTION - DRAWING SERIES L(30)01 - 11

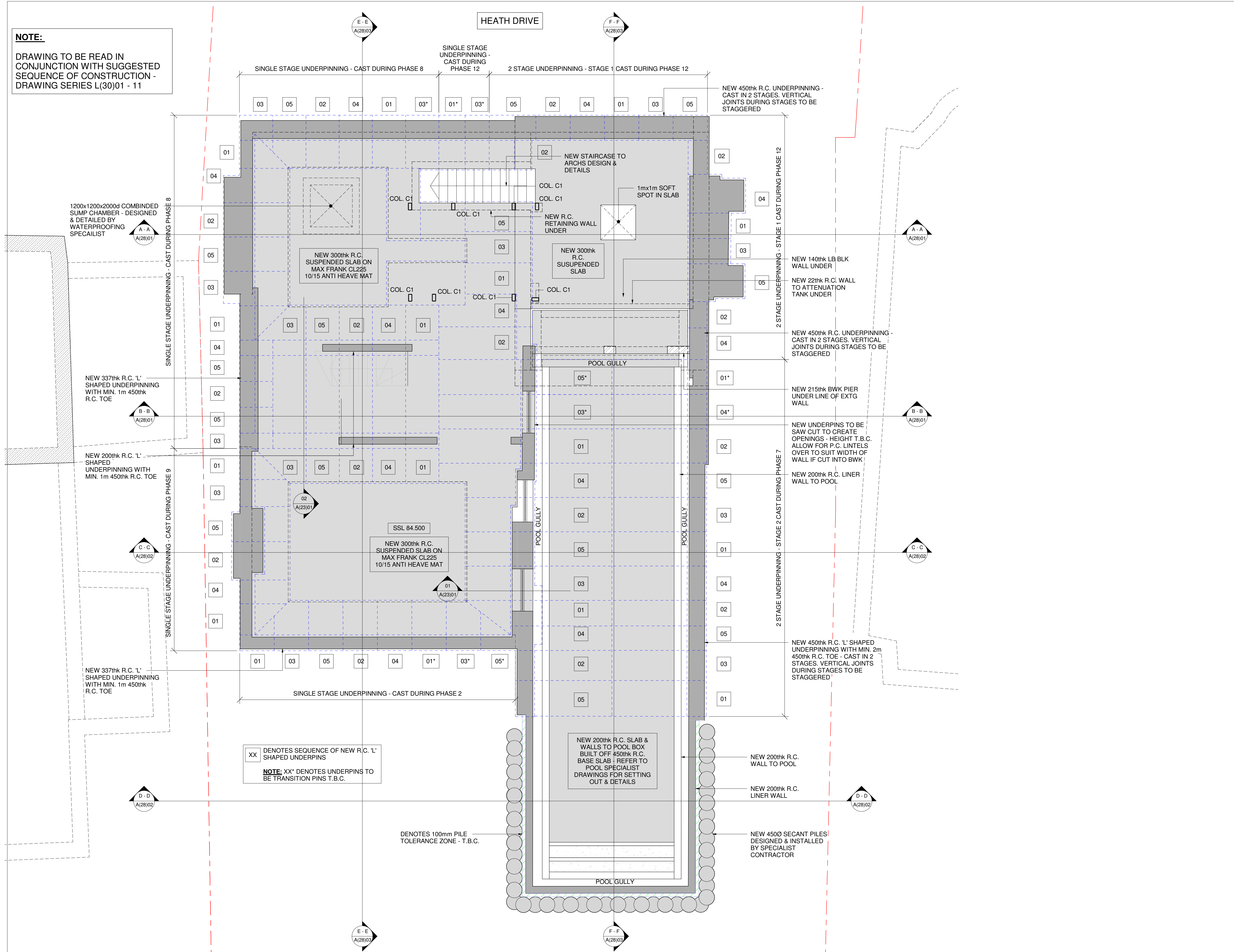

XX DENOTES SEQUENCE OF NEW R.C. 'L' SHAPED UNDERPINS
NOTE: XX* DENOTES UNDERPINS TO BE TRANSITION PINS T.B.C.

DENOTES 100mm PILE TOLERANCE ZONE - T.B.C.

NEW 200thk R.C. SLAB & WALLS TO POOL BOX BUILT OFF 450thk R.C. BASE SLAB - REFER TO POOL SPECIALIST DRAWINGS FOR SETTING OUT & DETAILS

Notes
THIS DRAWING IS COPYRIGHT OF FORM.
DO NOT SCALE FROM THIS DRAWING WORK ONLY TO FIGURED DIMENSIONS.
THE CONTRACTOR IS TO VERIFY ALL DIMENSIONS ON SITE BEFORE COMMENCING WORK. ALL ERRORS AND OMISSIONS ARE TO BE REPORTED TO THE ENGINEER.
THIS DRAWING IS TO BE READ IN CONJUNCTION WITH ALL RELEVANT ARCHITECTS, SERVICES ENGINEERS AND ENGINEERS DRAWINGS AND SPECIFICATIONS.

KEY

WALL TYPES	KEY
[Pattern]	EXISTING WALL
[Pattern]	NEW 20N/mm ² BRICKWORK IN DESIGNATION (iii) MORTAR.
[Pattern]	NEW 7N/mm ² MEDIUM DENSE BLOCKWORK IN DESIGNATION (iii) MORTAR.
[Pattern]	NEW LOADBEARING TIMBER STUD PARTITION (50x100 C24 STUDS AT 400c/c).
[Pattern]	NEW NON LOAD BEARING PARTITION.
[Pattern]	LOAD BEARING WALL UNDER.
[Pattern]	NEW BRICKWORK TO BE FULLY TOOTHED IN AND PACKED UP TO EXTG BRICKWORK PROFILES.
W	STAINLESS STEEL WALL EXTENSION PROFILES.
ALL MASONRY BELOW DPC LEVEL TO BE FROST RESISTANT AND IN DESIGNATION (j) MORTAR.	

LEGEND

[Symbol]	NEW BEAM UNDER.
[Symbol]	DOUBLED TIMBERS TRIMMING OPENINGS/ UNDER PARTITIONS.
[Symbol]	DENOTES SPAN OF NEW 50x200 C24 TIMBER JOISTS AT 400c/c U.N.O.
[Symbol]	DENOTES SPAN OF NEW 50x150 C24 TIMBER RAFTERS AT 400c/c U.N.O.
[Symbol]	DENOTES SPAN OF NEW 75x100 C24 TIMBER RAFTERS AT 400c/c U.N.O.
[Symbol]	DENOTES SPAN OF NEW CONCRETE SLAB
[Symbol]	DENOTES SPAN OF NEW 150mm DEEP BEAM & BLOCK FLOOR.
[Symbol]	DENOTES SPAN OF EXISTING TIMBER CEILING JOISTS. ASSUMED 50x100 T.B.C.
[Symbol]	DENOTES SPAN OF EXISTING TIMBER FLOOR JOISTS. ASSUMED 50x200 T.B.C.
TT	DENOTES DOUBLE TRIMMER JOIST/RAFTERS SIZED AS PER SPAN

STRUCTURAL COLUMN SCHEDULE

MARK	SIZE
COL. C1	RHS200x100x5.0
COL. C2	SHS100x100x10.0
COL. C3	UC152x152x37

P3	26.01.18	ISSUED FOR PLANNING	P.E	C.M
P2	15.12.17	POOL SLAB REVISED	P.E	C.M
P1	13.12.17	ISSUED FOR PLANNING	P.E	C.M
Rev.	Date	Amendment	Drawn	Chkd

Drawing Status **PRELIMINARY**

Form

Job Title
**24 HEATH DRIVE
LONDON
NW3 7SB**

Drawing Title
PROPOSED BASEMENT PLAN

Form Structural Design Ltd 77 St John Street London EC1M 4NN
T:020 7253 2893 E:studio@form-sd.com W:www.form-sd.com

Date	Scale	Drawn	Checked
DEC 17	As indicated	P.E	C.M
Job No.	Drawing No.	Revision	
162637	L(17)02	P3	

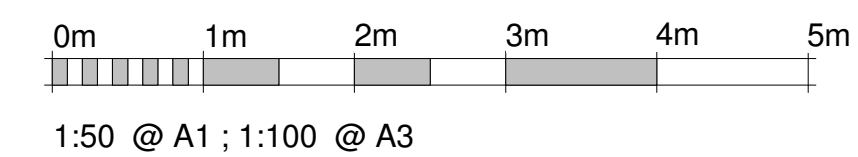

NOTE:
DRAWING TO BE READ IN CONJUNCTION WITH SUGGESTED SEQUENCE OF CONSTRUCTION - DRAWING SERIOES L(30)01 - 11

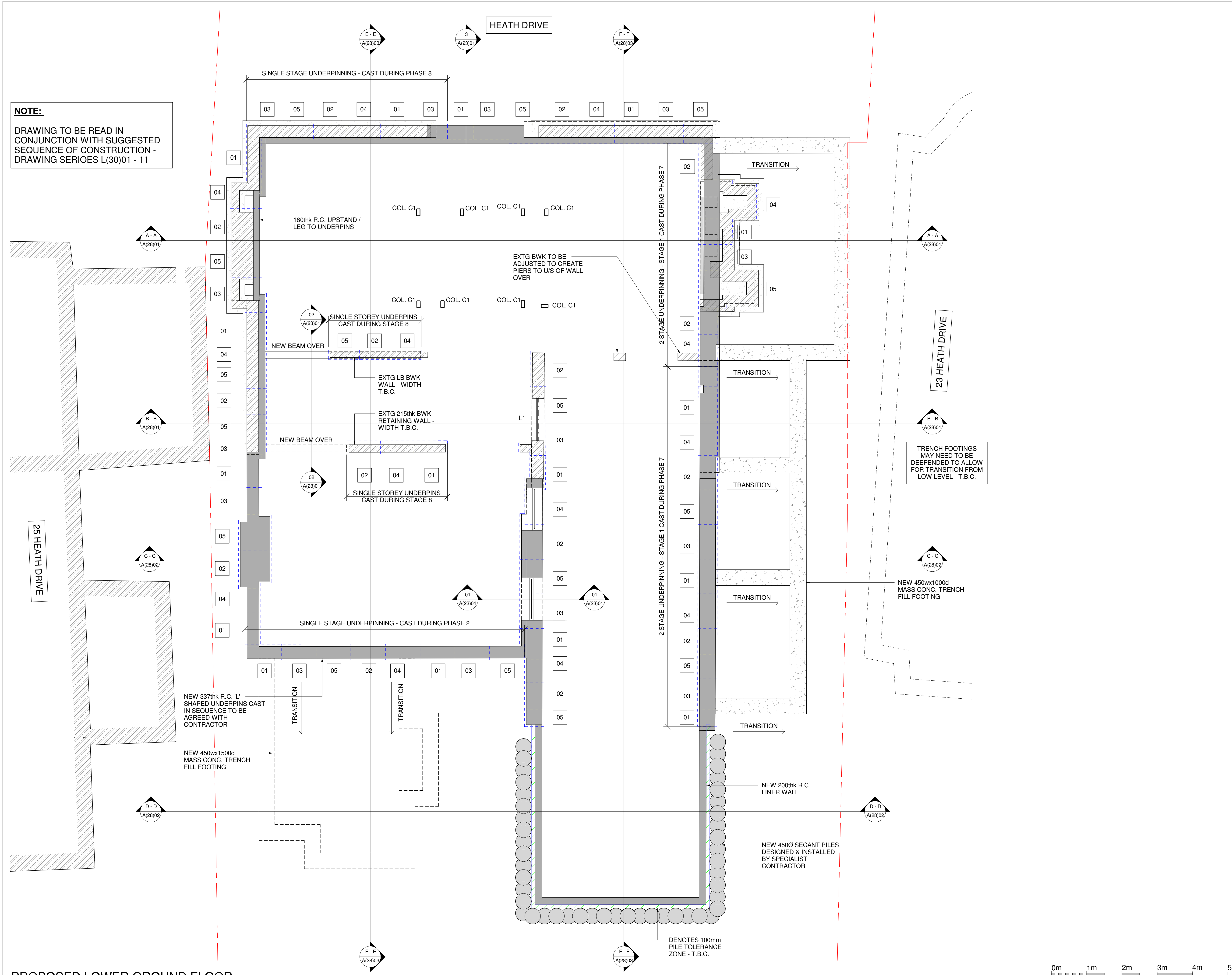

Notes
THIS DRAWING IS COPYRIGHT OF FORM.
DO NOT SCALE FROM THIS DRAWING WORK ONLY TO FIGURED DIMENSIONS.
THE CONTRACTOR IS TO VERIFY ALL DIMENSIONS ON SITE BEFORE COMMENCING WORK. ALL ERRORS AND OMISSIONS ARE TO BE REPORTED TO THE ENGINEER.
THIS DRAWING IS TO BE READ IN CONJUNCTION WITH ALL RELEVANT ARCHITECTS, SERVICES ENGINEERS AND ENGINEERS DRAWINGS AND SPECIFICATIONS.

KEY	
EXISTING WALL	
NEW 20N/mm ² BRICKWORK IN DESIGNATION (iii) MORTAR.	
NEW 7N/mm ² MEDIUM DENSE BLOCKWORK IN DESIGNATION (iii) MORTAR.	
NEW LOADBEARING TIMBER STUD PARTITION (50x100 C24 STUDS AT 400c/c).	
NEW NON LOAD BEARING PARTITION.	
LOAD BEARING WALL UNDER.	
NEW BRICKWORK TO BE FULLY TOOTHED IN AND PACKED UP TO EXTG BRICKWORK	
W STAINLESS STEEL WALL EXTENSION PROFILES.	
ALL MASONRY BELOW DPC LEVEL TO BE FROST RESISTANT AND IN DESIGNATION (i) MORTAR.	

LEGEND	
NEW BEAM UNDER.	
DOUBLED TIMBERS TRIMMING OPENINGS/ UNDER PARTITIONS.	
DENOTES SPAN OF NEW 50x200 C24 TIMBER JOISTS AT 400c/c U.N.O.	
DENOTES SPAN OF NEW 50x150 C24 TIMBER RAFTERS AT 400c/c U.N.O.	
DENOTES SPAN OF NEW 75x100 C24 TIMBER RAFTERS AT 400c/c U.N.O.	
DENOTES SPAN OF NEW CONCRETE SLAB	
DENOTES SPAN OF NEW 150mm DEEP BEAM & BLOCK FLOOR.	
DENOTES SPAN OF EXISTING TIMBER CEILING JOISTS. ASSUMED 50x100 T.B.C.	
DENOTES SPAN OF EXISTING TIMBER FLOOR JOISTS. ASSUMED 50x200 T.B.C.	
TT DENOTES DOUBLE TRIMMER JOIST/RAFTERS SIZED AS PER SPAN	

STRUCTURAL COLUMN SCHEDULE	
MARK	SIZE
COL. C1	RHS200x100x5.0
COL. C2	SHS100x100x10.0
COL. C3	UC152x152x37

P2	26.01.18	ISSUED FOR PLANNING	P.E	C.M
P1	13.12.17	ISSUED FOR PLANNING	P.E	C.M
Rev.	Date	Amendment	Drawn	Chkd

Drawing Status: **PRELIMINARY**

Form

Job Title
**24 HEATH DRIVE
LONDON
NW3 7SB**

Drawing Title
**PROPOSED LOWER GROUND
FLOOR PLAN**

Form Structural Design Ltd 77 St John Street London EC1M 4NN
T:020 7253 2893 E:studio@form-sd.com W:www.form-sd.com

Date	Scale	Drawn	Checked
DEC 17	As indicated	P.E	C.M
Job No.	Drawing No.	Revision	
162637	L(23)01	P2	

PROPOSED LOWER GROUND FLOOR
1 : 50

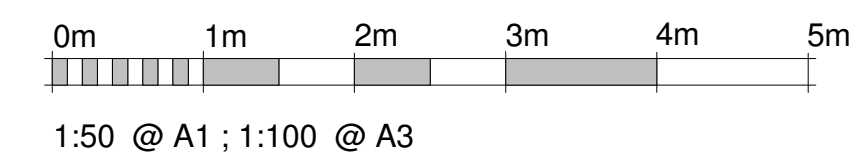

NOTE:
DRAWING TO BE READ IN CONJUNCTION WITH SUGGESTED SEQUENCE OF CONSTRUCTION - DRAWING SERIES L(30)01 - 11

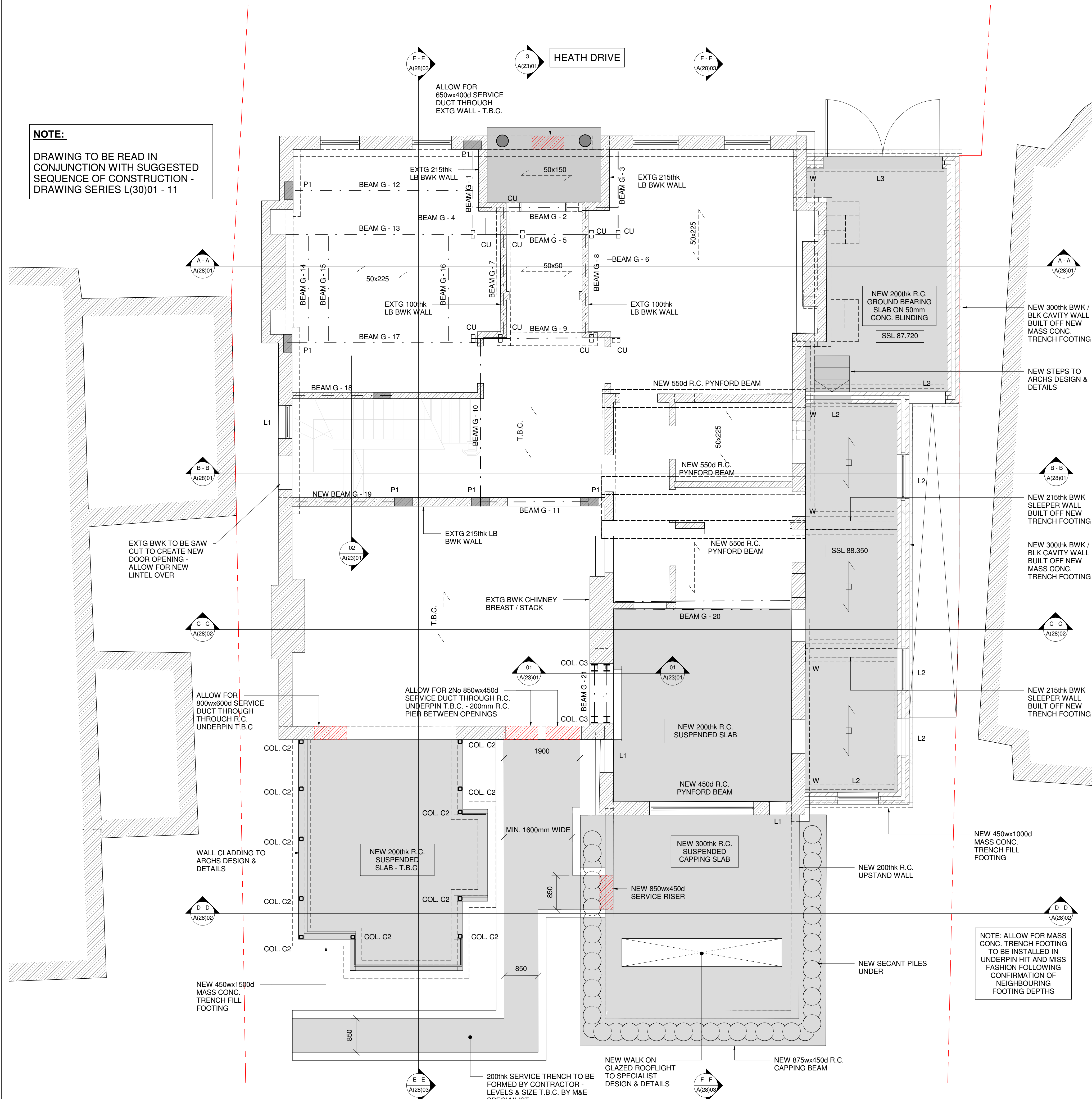

LINTEL SCHEDULE	
MARK	DESCRIPTION
L1	150dp PRE-STRESSED P.C LINTEL/S TO SUIT WIDTH OF WALL
L2	CG90/100 CATNIC CAVITY WALL LINTEL
L3	203x203 UC60

PADSTONE SCHEDULE	
MARK	DESCRIPTION
P1	450gx225dpxWIDTH OF WALL MASS CONCRETE

STRUCTURAL GROUND FLOOR STEEL BEAM SCHEDULE	
Mark	SIZE
BEAM G - 1	UC203x203x46
BEAM G - 2	UC203x203x46
BEAM G - 3	UC203x203x46
BEAM G - 4	UC203x203x46
BEAM G - 5	UC203x203x46
BEAM G - 6	UC203x203x46
BEAM G - 7	UC203x203x46
BEAM G - 8	UC203x203x46
BEAM G - 9	UC203x203x46
BEAM G - 10	UC203x203x46
BEAM G - 11	UB203x133x30
BEAM G - 12	UC203x203x60
BEAM G - 13	UC203x203x60
BEAM G - 14	UB203x133x30
BEAM G - 15	UB203x133x30
BEAM G - 16	UB203x133x30
BEAM G - 17	UC203x203x60
BEAM G - 18	UC203x203x60
BEAM G - 20	2No PFC200x90x30'S WITH 12mm WELDED BOTTOM PLATE WELDED TO 1 BEAM & BOLTED TO OTHER (6mm C.F.W. & M12 BOLTS @ 350c/c)
BEAM G - 21	2No UC203x203x60'S

STRUCTURAL COLUMN SCHEDULE	
MARK	SIZE
COL. C1	RHS200x100x5.0
COL. C2	SHS100x100x10.0
COL. C3	UC152x152x37

Notes
THIS DRAWING IS COPYRIGHT OF FORM.
DO NOT SCALE FROM THIS DRAWING WORK ONLY TO FIGURED DIMENSIONS.
THE CONTRACTOR IS TO VERIFY ALL DIMENSIONS ON SITE BEFORE COMMENCING WORK. ALL ERRORS AND OMISSIONS ARE TO BE REPORTED TO THE ENGINEER.
THIS DRAWING IS TO BE READ IN CONJUNCTION WITH ALL RELEVANT ARCHITECTS, SERVICES ENGINEERS AND ENGINEERS DRAWINGS AND SPECIFICATIONS.

KEY	
WALL TYPES	KEY
	EXISTING WALL
	NEW 20N/mm² BRICKWORK IN DESIGNATION (iii) MORTAR.
	NEW 7N/mm² MEDIUM DENSE BLOCKWORK IN DESIGNATION (iii) MORTAR.
	NEW LOADBearing TIMBER STUD PARTITION (50x100 C24 STUDS AT 400c/c).
	NEW NON LOAD BEARING PARTITION.
	LOAD BEARING WALL UNDER.
	NEW BRICKWORK TO BE FULLY TOOTHED IN AND PACKED UP TO EXTG BRICKWORK
	STAINLESS STEEL WALL EXTENSION PROFILES.
ALL MASONRY BELOW DPC LEVEL TO BE FROST RESISTANT AND IN DESIGNATION (i) MORTAR.	
LEGEND	
	NEW BEAM UNDER.
	DOUBLED TIMBERS TRIMMING OPENINGS/ UNDER PARTITIONS.
	NOTES SPAN OF NEW 50x200 C24 TIMBER JOISTS AT 400c/c U.N.O.
	NOTES SPAN OF NEW 50x150 C24 TIMBER RAFTERS AT 400c/c U.N.O.
	NOTES SPAN OF NEW 75x100 C24 TIMBER RAFTERS AT 400c/c U.N.O.
	NOTES SPAN OF NEW CONCRETE SLAB
	NOTES SPAN OF NEW 150mm DEEP BEAM & BLOCK FLOOR.
	NOTES SPAN OF EXISTING TIMBER CEILING JOISTS. ASSUMED 50x100 T.B.C.
	NOTES SPAN OF EXISTING TIMBER FLOOR JOISTS. ASSUMED 50x200 T.B.C.
	NOTES DOUBLE TRIMMER JOIST/RAFTERS SIZED AS PER SPAN

Rev.	Date	Amendment	Drawn	Chkd
P4	06.02.18	SERVICE TRENCH REVISED	P.E	C.M
P3	29.01.18	SECTION MARK 03 ADDED	P.E	C.M
P2	26.01.18	ISSUED FOR PLANNING	P.E	C.M
P1	13.12.17	ISSUED FOR PLANNING	P.E	C.M

Drawing Status: **PRELIMINARY**

Form

Job Title
**24 HEATH DRIVE
LONDON
NW3 7SB**

Drawing Title
PROPOSED GROUND FLOOR PLAN

Form Structural Design Ltd 77 St John Street London EC1M 4NN
T:020 7253 2893 E:studio@form-sd.com W:www.form-sd.com

Date	Scale	Drawn	Checked
DEC 17	As indicated	P.E	C.M
Job No. 162637	Drawing No. L(23)02	Revision P4	

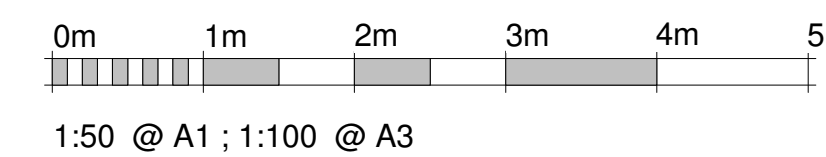

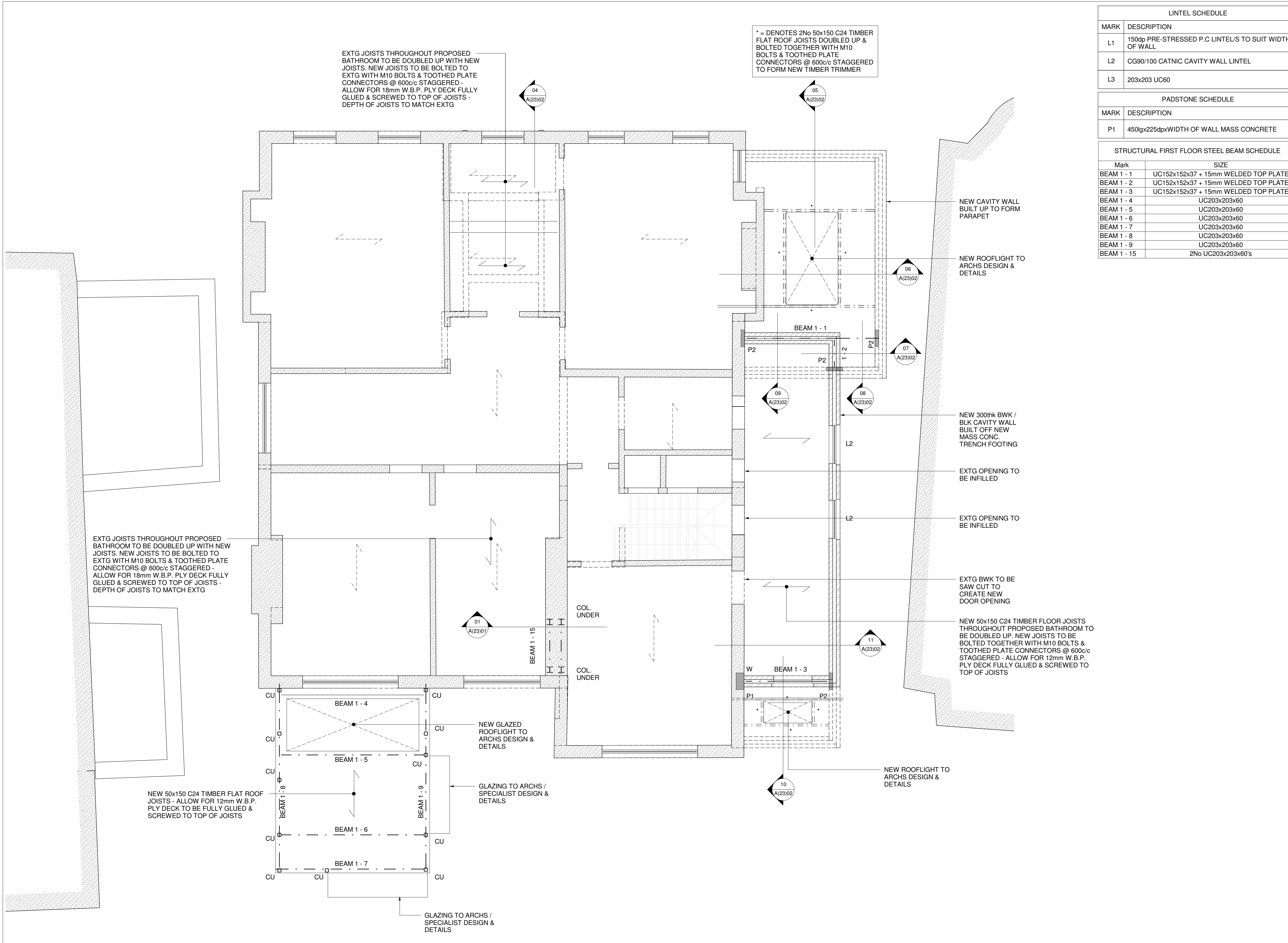

LINTEL SCHEDULE	
MARK	DESCRIPTION
L1	150dp PRE-STRESSED P.C LINTEL/S TO SUIT WIDTH OF WALL
L2	CG90/100 CATNIC CAVITY WALL LINTEL
L3	203x203 UC60

PADSTONE SCHEDULE	
MARK	DESCRIPTION
P1	450gx225dpxWIDTH OF WALL MASS CONCRETE

STRUCTURAL FIRST FLOOR STEEL BEAM SCHEDULE	
Mark	SIZE
BEAM 1 - 1	UC152x152x37 + 15mm WELDED TOP PLATE
BEAM 1 - 2	UC152x152x37 + 15mm WELDED TOP PLATE
BEAM 1 - 3	UC152x152x37 + 15mm WELDED TOP PLATE
BEAM 1 - 4	UC203x203x60
BEAM 1 - 5	UC203x203x60
BEAM 1 - 6	UC203x203x60
BEAM 1 - 7	UC203x203x60
BEAM 1 - 8	UC203x203x60
BEAM 1 - 9	UC203x203x60
BEAM 1 - 15	2No UC203x203x60's

Notes
 THIS DRAWING IS COPYRIGHT OF FORM.
 DO NOT SCALE FROM THIS DRAWING WORK ONLY TO FIGURED DIMENSIONS.
 THE CONTRACTOR IS TO VERIFY ALL DIMENSIONS ON SITE BEFORE COMMENCING WORK. ALL ERRORS AND OMISSIONS ARE TO BE REPORTED TO THE ENGINEER.
 THIS DRAWING IS TO BE READ IN CONJUNCTION WITH ALL RELEVANT ARCHITECTS, SERVICES ENGINEERS AND ENGINEERS DRAWINGS AND SPECIFICATIONS.

KEY	
WALL TYPES	
	EXISTING WALL
	NEW 20N/mm² BRICKWORK IN DESIGNATION (iii) MORTAR.
	NEW 7N/mm² MEDIUM DENSE BLOCKWORK IN DESIGNATION (iii) MORTAR.
	NEW LOADBEARING TIMBER STUD PARTITION (50x100 C24 STUDS AT 400c/c).
	NEW NON LOAD BEARING PARTITION.
	LOAD BEARING WALL UNDER.
	NEW BRICKWORK TO BE FULLY TOOTHED IN AND PACKED UP TO EXTG BRICKWORK PROFILES.
	STAINLESS STEEL WALL EXTENSION PROFILES.
ALL MASONRY BELOW DPC LEVEL TO BE FROST RESISTANT AND IN DESIGNATION (i) MORTAR.	
LEGEND	
	NEW BEAM UNDER.
	DOUBLED TIMBERS TRIMMING OPENINGS/ UNDER PARTITIONS.
	DENOTES SPAN OF NEW 50x200 C24 TIMBER JOISTS AT 400c/c U.N.O.
	DENOTES SPAN OF NEW 50x150 C24 TIMBER RAFTERS AT 400c/c U.N.O.
	DENOTES SPAN OF NEW 75x100 C24 TIMBER RAFTERS AT 400c/c U.N.O.
	DENOTES SPAN OF NEW CONCRETE SLAB
	DENOTES SPAN OF NEW 150mm DEEP BEAM & BLOCK FLOOR.
	DENOTES SPAN OF EXISTING TIMBER CEILING JOISTS. ASSUMED 50x100 T.B.C.
	DENOTES SPAN OF EXISTING TIMBER FLOOR JOISTS. ASSUMED 50x200 T.B.C.
	TT DENOTES DOUBLE TRIMMER JOIST/RAFTERS SIZED AS PER SPAN

P2	29.01.18	SECTION MARKS ADDED	P.E	C.M
Rev.	Date	Amendment	Drawn	Chkd
	26.01.18	ISSUED FOR PLANNING	P.E	C.M

Drawing Status: **PRELIMINARY**

Form

Job Title
**24 HEATH DRIVE
 LONDON
 NW3 7SB**

Drawing Title
PROPOSED FIRST FLOOR PLAN

Form Structural Design Ltd 77 St John Street London EC1M 4NN
 T:020 7253 2893 E:studio@form-sd.com W:www.form-sd.com

Date	Scale	Drawn	Checked
JAN 18	As indicated	P.E	C.M
Job No.	Drawing No.	Revision	
162637	L(23)03	P2	

PROPOSED FIRST FLOOR LEVEL
 1 : 50

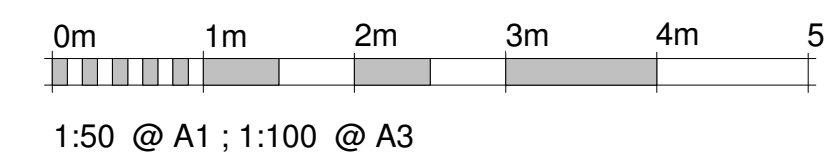

LINTEL SCHEDULE	
MARK	DESCRIPTION
L1	150dp PRE-STRESSED P.C LINTEL/S TO SUIT WIDTH OF WALL
L2	CG90/100 CATNIC CAVITY WALL LINTEL
L3	203x203 UC60

PADSTONE SCHEDULE	
MARK	DESCRIPTION
P1	450gx225dpxWIDTH OF WALL MASS CONCRETE

STRUCTURAL ROOF STEEL BEAM SCHEDULE	
Mark	SIZE
BEAM R - 1	
BEAM R - 2 (PITCHED)	UC152x152x37
BEAM R - 3	UC152x152x37
BEAM R - 4 (PITCHED)	UC152x152x37
BEAM R - 5 (PITCHED)	UC203x203x71
BEAM R - 6	UC203x203x71
BEAM R - 7	UC203x203x71
BEAM R - 8 (PITCHED)	UC203x203x71
BEAM R - 9	UC203x203x71
BEAM R - 10	UC152x152x23
BEAM R - 11 (PITCHED)	UC203x203x71
BEAM R - 12	UC203x203x71
BEAM R - 13	UC203x203x71
BEAM R - 14 (PITCHED)	UC203x203x71
BEAM R - 15	UC203x203x71
BEAM R - 16	UB203x133x30
BEAM R - 17	UC203x203x71
BEAM R - 18	UC203x203x60

Notes
 THIS DRAWING IS COPYRIGHT OF FORM.
 DO NOT SCALE FROM THIS DRAWING WORK ONLY TO FIGURED DIMENSIONS.
 THE CONTRACTOR IS TO VERIFY ALL DIMENSIONS ON SITE BEFORE COMMENCING WORK. ALL ERRORS AND OMISSIONS ARE TO BE REPORTED TO THE ENGINEER.
 THIS DRAWING IS TO BE READ IN CONJUNCTION WITH ALL RELEVANT ARCHITECTS, SERVICES ENGINEERS AND ENGINEERS DRAWINGS AND SPECIFICATIONS.

KEY	
WALL TYPES	
	EXISTING WALL
	NEW 20N/mm² BRICKWORK IN DESIGNATION (iii) MORTAR.
	NEW 7N/mm² MEDIUM DENSE BLOCKWORK IN DESIGNATION (iii) MORTAR.
	NEW LOADBEARING TIMBER STUD PARTITION (50x100 C24 STUDS AT 400c/c).
	NEW NON LOAD BEARING PARTITION.
	LOAD BEARING WALL UNDER.
	NEW BRICKWORK TO BE FULLY TOOTHED IN AND PACKED UP TO EXTG BRICKWORK
	W STAINLESS STEEL WALL EXTENSION PROFILES.
ALL MASONRY BELOW DPC LEVEL TO BE FROST RESISTANT AND IN DESIGNATION (i) MORTAR.	
LEGEND	
	NEW BEAM UNDER.
	DOUBLED TIMBERS TRIMMING OPENINGS/ UNDER PARTITIONS.
	DENOTES SPAN OF NEW 50x200 C24 TIMBER JOISTS AT 400c/c U.N.O.
	DENOTES SPAN OF NEW 50x150 C24 TIMBER RAFTERS AT 400c/c U.N.O.
	DENOTES SPAN OF NEW 75x100 C24 TIMBER RAFTERS AT 400c/c U.N.O.
	DENOTES SPAN OF NEW CONCRETE SLAB
	DENOTES SPAN OF NEW 150mm DEEP BEAM & BLOCK FLOOR.
	DENOTES SPAN OF EXISTING TIMBER CEILING JOISTS. ASSUMED 50x100 T.B.C.
	DENOTES SPAN OF EXISTING TIMBER FLOOR JOISTS. ASSUMED 50x200 T.B.C.
	TT DENOTES DOUBLE TRIMMER JOIST/RAFTERS SIZED AS PER SPAN

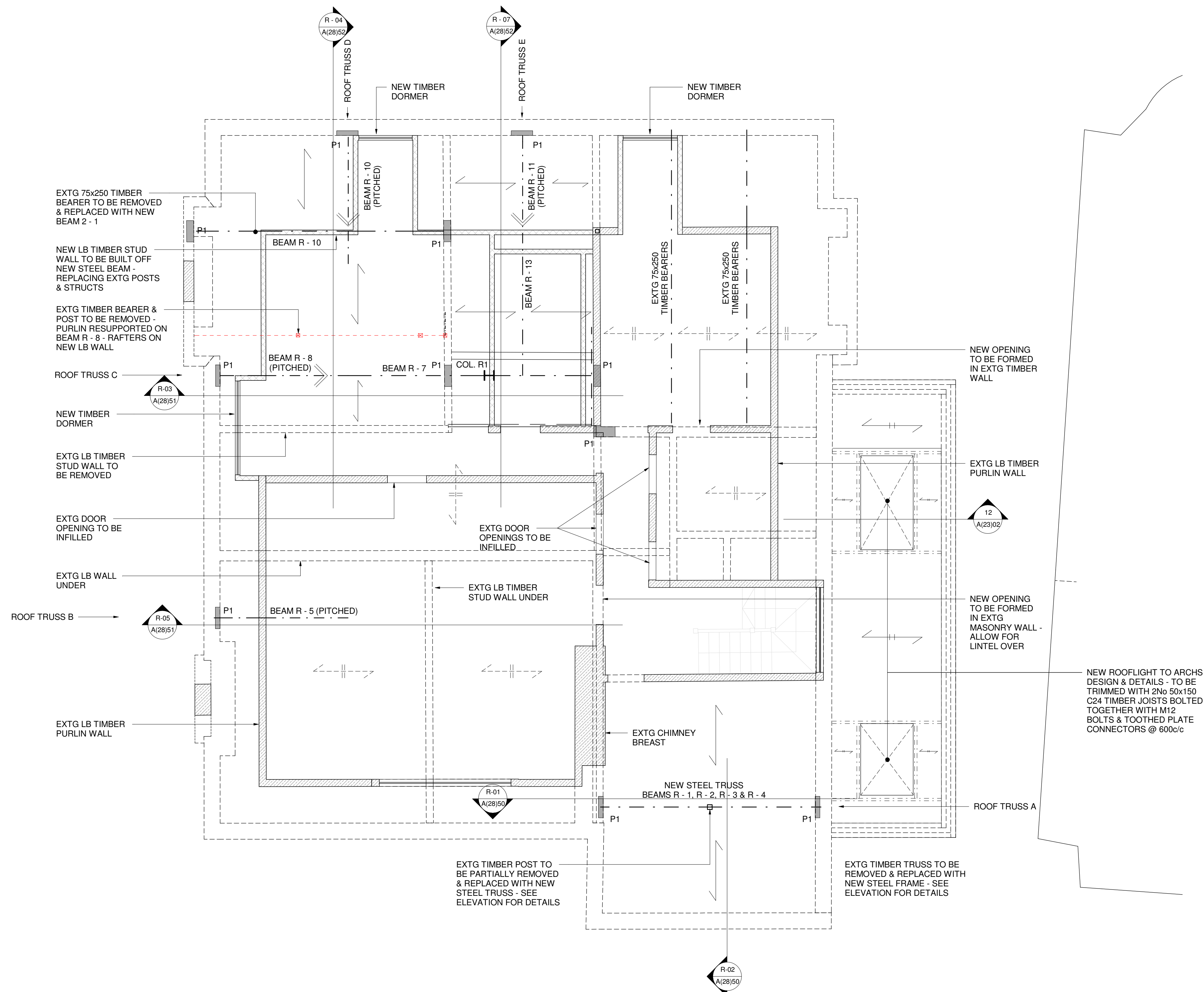

PROPOSED SECOND FLOOR LEVEL

1:50

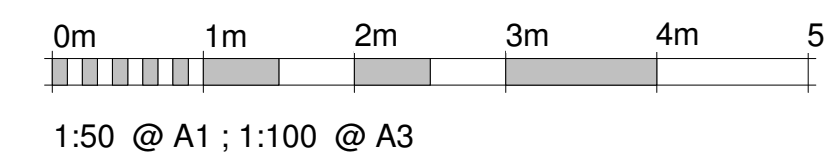

P3	06.02.18	DORMERS ADDED & FRAME POSITIONS REVISED	P.E	C.M
P2	29.01.18	SECTION MARK 12 ADDED	P.E	C.M
P1	26.01.18	ISSUED FOR PLANNING	P.E	C.M
Rev.	Date	Amendment	Drawn	Chkd

Drawing Status **PRELIMINARY**

Form

Job Title
**24 HEATH DRIVE
 LONDON
 NW3 7SB**

Drawing Title
PROPOSED SECOND FLOOR PLAN

Date	Scale	Drawn	Checked
JAN 18	As indicated	P.E	C.M
Job No.	Drawing No.	Revision	
162637	L(23)04	P3	

Form Structural Design Ltd 77 St John Street London EC1M 4NN
 T:020 7253 2893 E:studio@form-sd.com W:www.form-sd.com

HEATH DRIVE

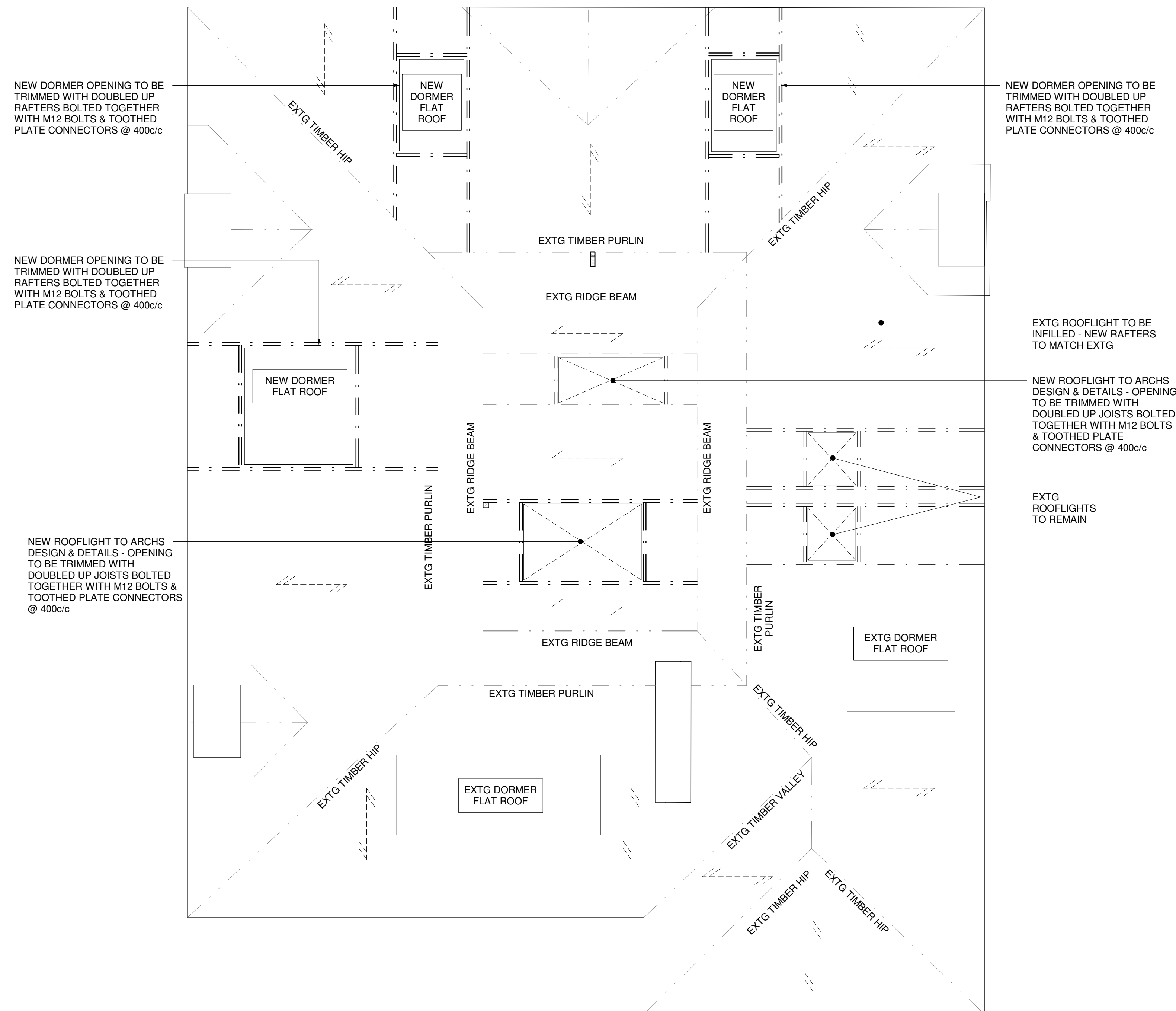

NEW DORMER OPENING TO BE TRIMMED WITH DOUBLED UP RAFTERS BOLTED TOGETHER WITH M12 BOLTS & TOOTHED PLATE CONNECTORS @ 400c/c

NEW DORMER OPENING TO BE TRIMMED WITH DOUBLED UP RAFTERS BOLTED TOGETHER WITH M12 BOLTS & TOOTHED PLATE CONNECTORS @ 400c/c

NEW ROOFLIGHT TO ARCHS DESIGN & DETAILS - OPENING TO BE TRIMMED WITH DOUBLED UP JOISTS BOLTED TOGETHER WITH M12 BOLTS & TOOTHED PLATE CONNECTORS @ 400c/c

NEW DORMER OPENING TO BE TRIMMED WITH DOUBLED UP RAFTERS BOLTED TOGETHER WITH M12 BOLTS & TOOTHED PLATE CONNECTORS @ 400c/c

EXTG ROOFLIGHT TO BE INFILLED - NEW RAFTERS TO MATCH EXTG

NEW ROOFLIGHT TO ARCHS DESIGN & DETAILS - OPENING TO BE TRIMMED WITH DOUBLED UP JOISTS BOLTED TOGETHER WITH M12 BOLTS & TOOTHED PLATE CONNECTORS @ 400c/c

EXTG ROOFLIGHTS TO REMAIN

Notes
 THIS DRAWING IS COPYRIGHT OF FORM.
 DO NOT SCALE FROM THIS DRAWING WORK ONLY TO FIGURED DIMENSIONS.
 THE CONTRACTOR IS TO VERIFY ALL DIMENSIONS ON SITE BEFORE COMMENCING WORK. ALL ERRORS AND OMISSIONS ARE TO BE REPORTED TO THE ENGINEER.
 THIS DRAWING IS TO BE READ IN CONJUNCTION WITH ALL RELEVANT ARCHITECTS, SERVICES ENGINEERS AND ENGINEERS DRAWINGS AND SPECIFICATIONS.

KEY	
WALL TYPES	
	EXISTING WALL
	NEW 20N/mm² BRICKWORK IN DESIGNATION (iii) MORTAR.
	NEW 7N/mm² MEDIUM DENSE BLOCKWORK IN DESIGNATION (iii) MORTAR.
	NEW LOADBEARING TIMBER STUD PARTITION (50x100 C24 STUDS AT 400c/c).
	NEW NON LOAD BEARING PARTITION.
	LOAD BEARING WALL UNDER.
	NEW BRICKWORK TO BE FULLY TOOTHED IN AND PACKED UP TO EXTG BRICKWORK
W	STAINLESS STEEL WALL EXTENSION PROFILES.
ALL MASONRY BELOW DPC LEVEL TO BE FROST RESISTANT AND IN DESIGNATION (i) MORTAR.	
LEGEND	
	NEW BEAM UNDER.
	DOUBLED TIMBERS TRIMMING OPENINGS/ UNDER PARTITIONS.
	DENOTES SPAN OF NEW 50x200 C24 TIMBER JOISTS AT 400c/c U.N.O.
	DENOTES SPAN OF NEW 50x150 C24 TIMBER RAFTERS AT 400c/c U.N.O.
	DENOTES SPAN OF NEW 75x100 C24 TIMBER RAFTERS AT 400c/c U.N.O.
	DENOTES SPAN OF NEW CONCRETE SLAB
	DENOTES SPAN OF NEW 150mm DEEP BEAM & BLOCK FLOOR.
	DENOTES SPAN OF EXISTING TIMBER CEILING JOISTS. ASSUMED 50x100 T.B.C.
	DENOTES SPAN OF EXISTING TIMBER FLOOR JOISTS. ASSUMED 50x200 T.B.C.
TT	DENOTES DOUBLE TRIMMER JOIST/RAFTERS SIZED AS PER SPAN

P1	06.02.18	ISSUED FOR PLANNING	P.E	C.M
Rev.	Date	Amendment	Drawn	Chkd

Drawing Status **PRELIMINARY**

Form

Job Title
**24 HEATH DRIVE
 LONDON
 NW3 7SB**

Drawing Title
PROPOSED ROOF PLAN

Form Structural Design Ltd 77 St John Street London EC1M 4NN
 T:020 7253 2893 E:studio@form-sd.com W:www.form-sd.com

Date	Scale	Drawn	Checked
JAN 18	As indicated	P.E	C.M
Job No.	Drawing No.	Revision	
162637	L(23)05	P1	

PROPOSED ROOF LEVEL

1 : 50

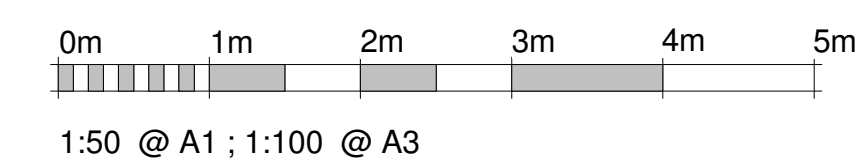

Notes:
 THIS DRAWING IS COPYRIGHT OF FORM
 DO NOT SCALE FROM THIS DRAWING WORK ONLY TO FIGURED DIMENSIONS.
 THE CONTRACTOR IS TO VERIFY ALL DIMENSIONS ON SITE BEFORE COMMENCING WORK. ALL ERRORS AND OMISSIONS ARE TO BE REPORTED TO THE ENGINEER.
 THIS DRAWING IS TO BE READ IN CONJUNCTION WITH ALL RELEVANT ARCHITECTS, SERVICES ENGINEERS AND ENGINEERS DRAWINGS AND SPECIFICATIONS.

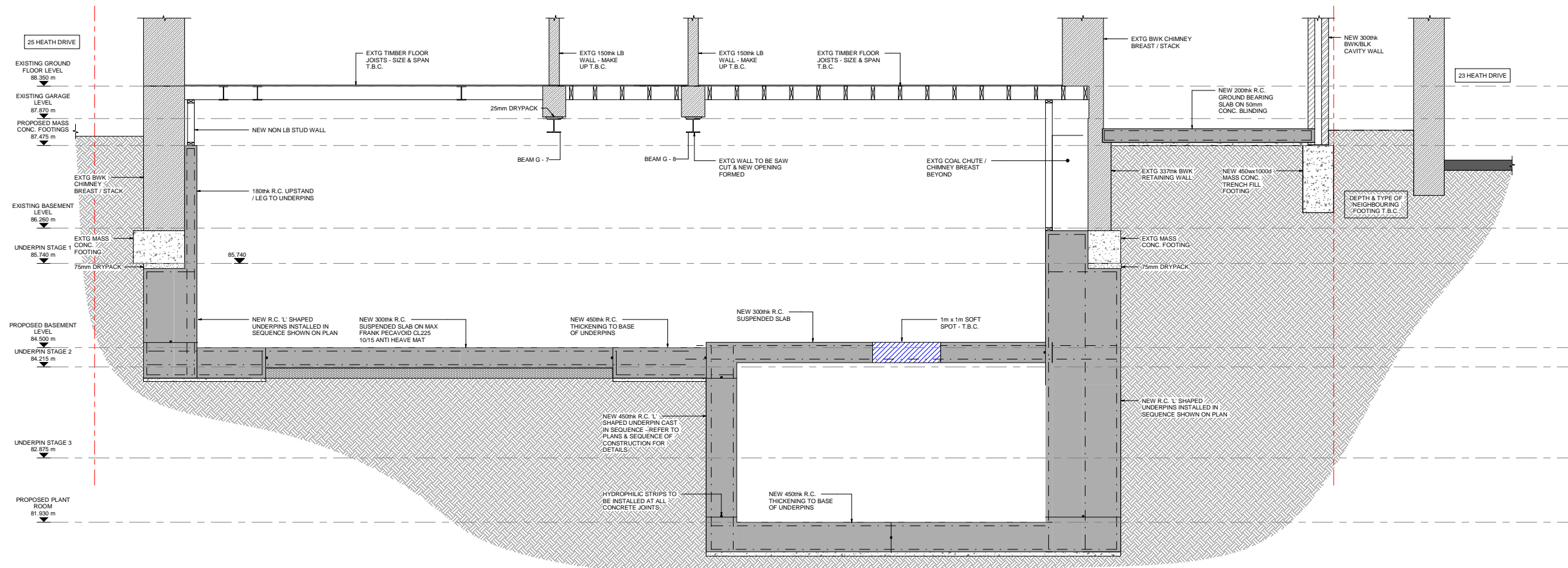

PROPOSED CROSS SECTION A - A
 1 : 25

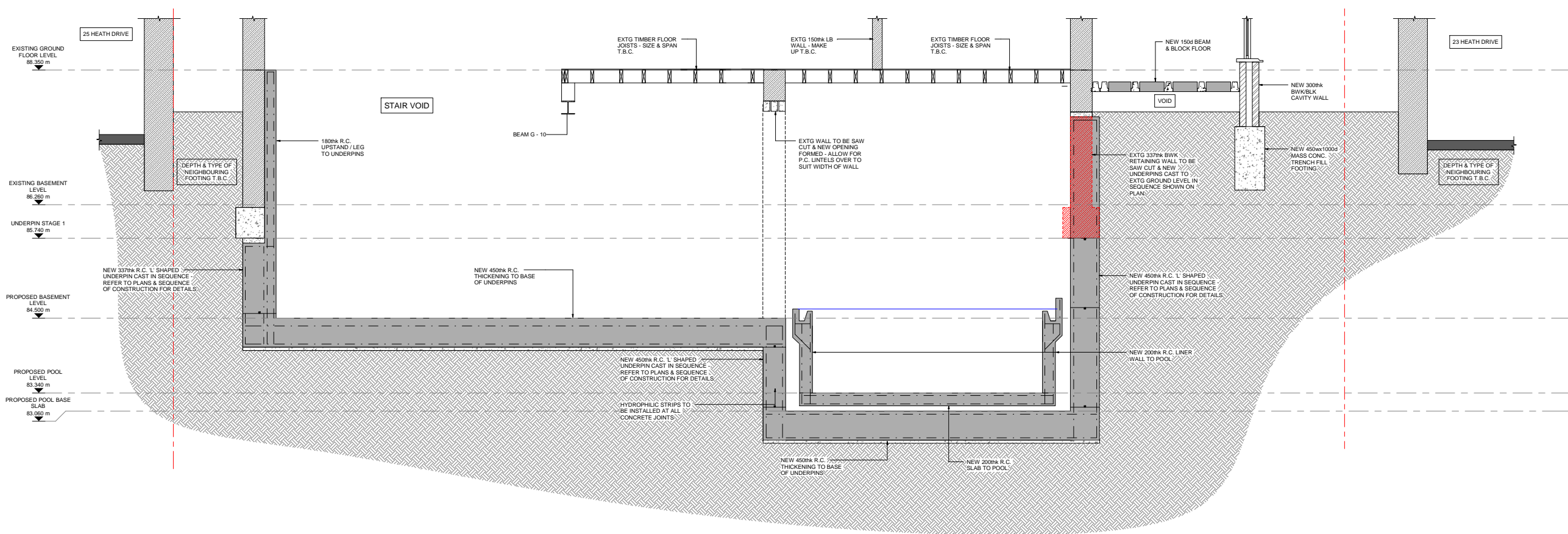

PROPOSED CROSS SECTION B - B
 1 : 25

P3	26.01.18	ISSUED FOR PLANNING	P.E	C.M
P2	15.12.17	WALL THICKENING ADDED	P.E	C.M
P1	13.12.17	ISSUED FOR PLANNING	P.E	C.M
Rev.	Date	Amendment	Drawn	Check

Drawing Status: PRELIMINARY

Form

Job Title:
 24 HEATH DRIVE
 LONDON
 NW3 7SB

Drawing Title:
 PROPOSED CROSS SECTIONS
 A - A & B - B

Form Structural Design Ltd
 T: 020 7253 2893 E: studio@form-sd.com W: www.form-sd.com

Date	Scale	Drawn	Checked
DEC 17	1 : 25	P.E	C.M
Job No.	Drawing No.	Revision	
162637-	A(28)01	P3	

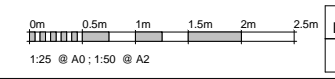

Note:
 THIS DRAWING IS COPYRIGHT OF FORM
 DO NOT SCALE FROM THIS DRAWING WORK ONLY TO FIGURED DIMENSIONS.
 THE CONTRACTOR IS TO VERIFY ALL DIMENSIONS ON SITE BEFORE COMMENCING WORK. ALL ERRORS AND OMISSIONS ARE TO BE REPORTED TO THE ENGINEER.
 THIS DRAWING IS TO BE READ IN CONJUNCTION WITH ALL RELEVANT ARCHITECTS, SERVICES ENGINEERS AND ENGINEERS DRAWINGS AND SPECIFICATIONS.

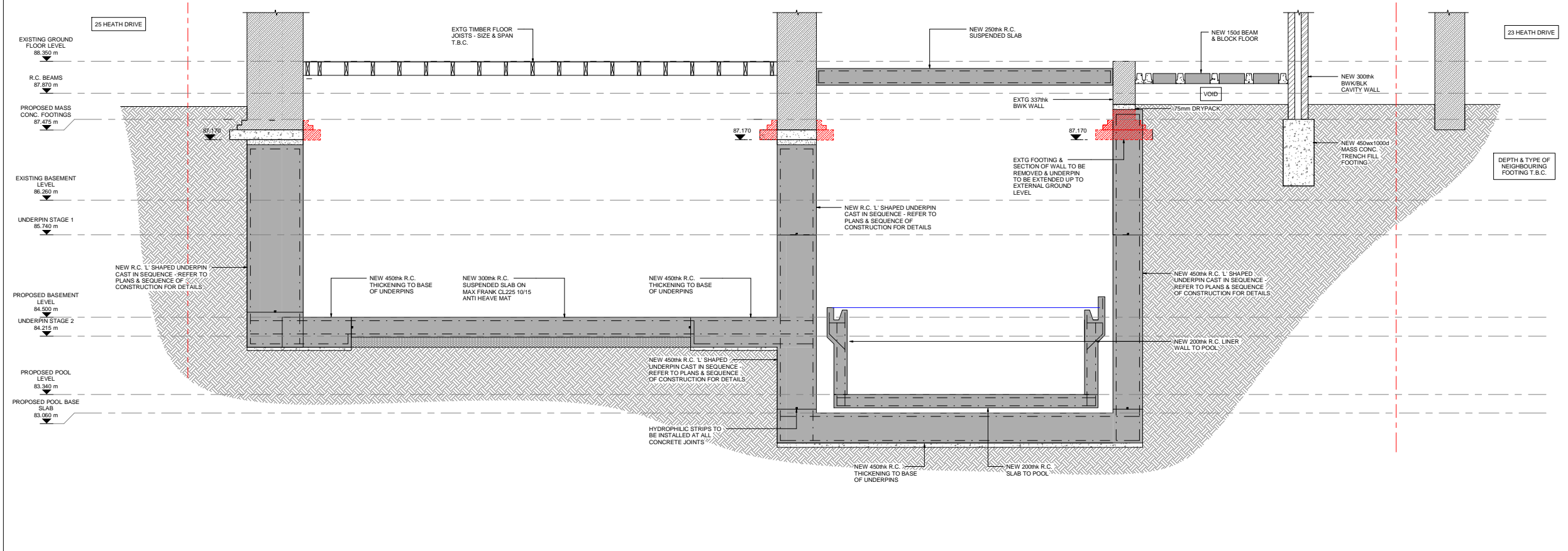

PROPOSED CROSS SECTION C - C
 1:25

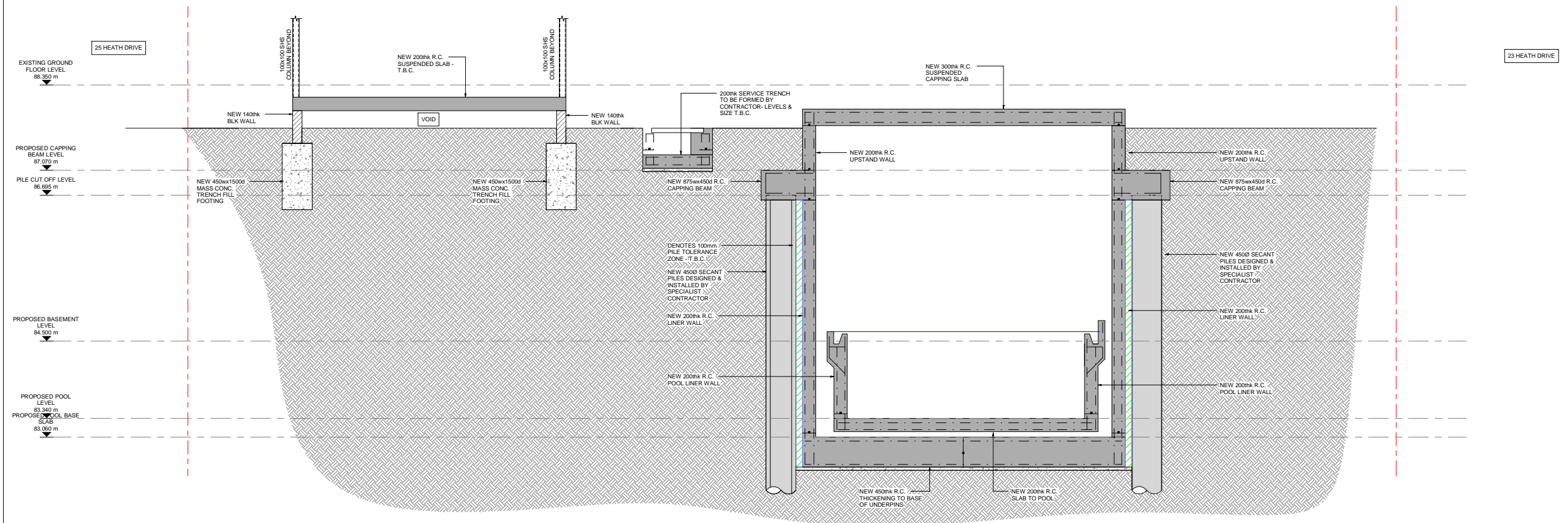

PROPOSED CROSS SECTION D - D
 1:25

P3	26.01.18	ISSUED FOR PLANNING	P.E	C.M
P2	15.12.17	WALL THICKENING ADDED	P.E	C.M
P1	13.12.17	ISSUED FOR PLANNING	P.E	C.M
Rev.	Date	Amendment	Drawn	Checkd

Drawing Status: PRELIMINARY

Form

Job Title:
 24 HEATH DRIVE
 LONDON
 NW3 7SB

Drawing Title:
 PROPOSED CROSS SECTIONS C - C & D - D

Form Structural Design Ltd 77 St John Street London EC1M 4BN
 T:020 7253 2893 E:studio@form-sd.com W:www.form-sd.com

Date	Scale	Drawn	Checked
DEC 17	1:25	P.E	C.M
Job No.	Drawing No.	Revision	
162637-	A(28)02	P3	



Notes:
 THIS DRAWING IS COPYRIGHT OF FORM
 DO NOT SCALE FROM THIS DRAWING WORK ONLY TO FIGURED DIMENSIONS.
 THE CONTRACTOR IS TO VERIFY ALL DIMENSIONS ON SITE BEFORE COMMENCING WORK. ALL ERRORS AND OMISSIONS ARE TO BE REPORTED TO THE ENGINEERS.
 THIS DRAWING IS TO BE READ IN CONJUNCTION WITH ALL RELEVANT ARCHITECTS, SERVICES ENGINEERS AND ENGINEERS DRAWINGS AND SPECIFICATIONS.

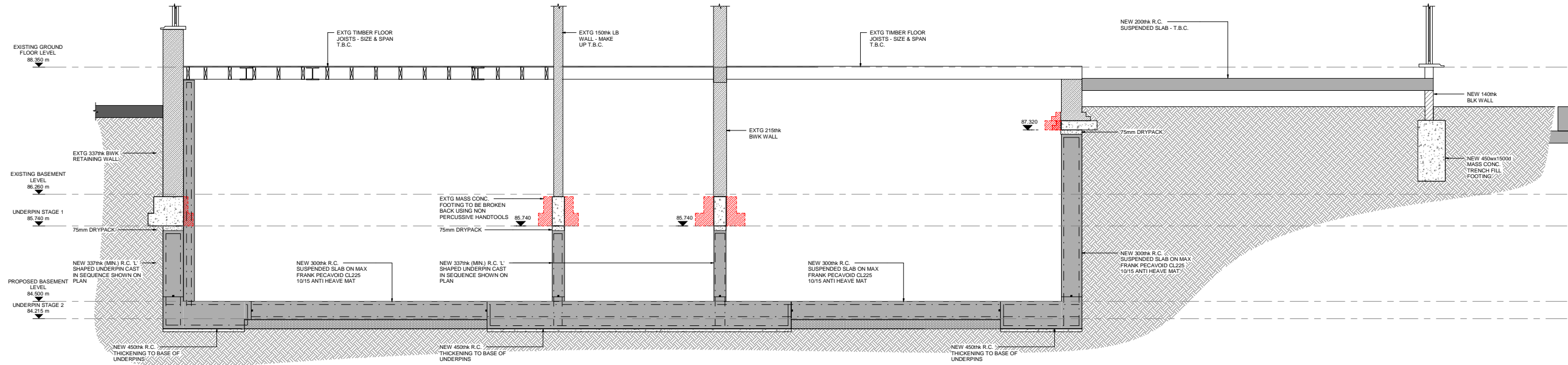

PROPOSED CROSS SECTION E - E
 1:25

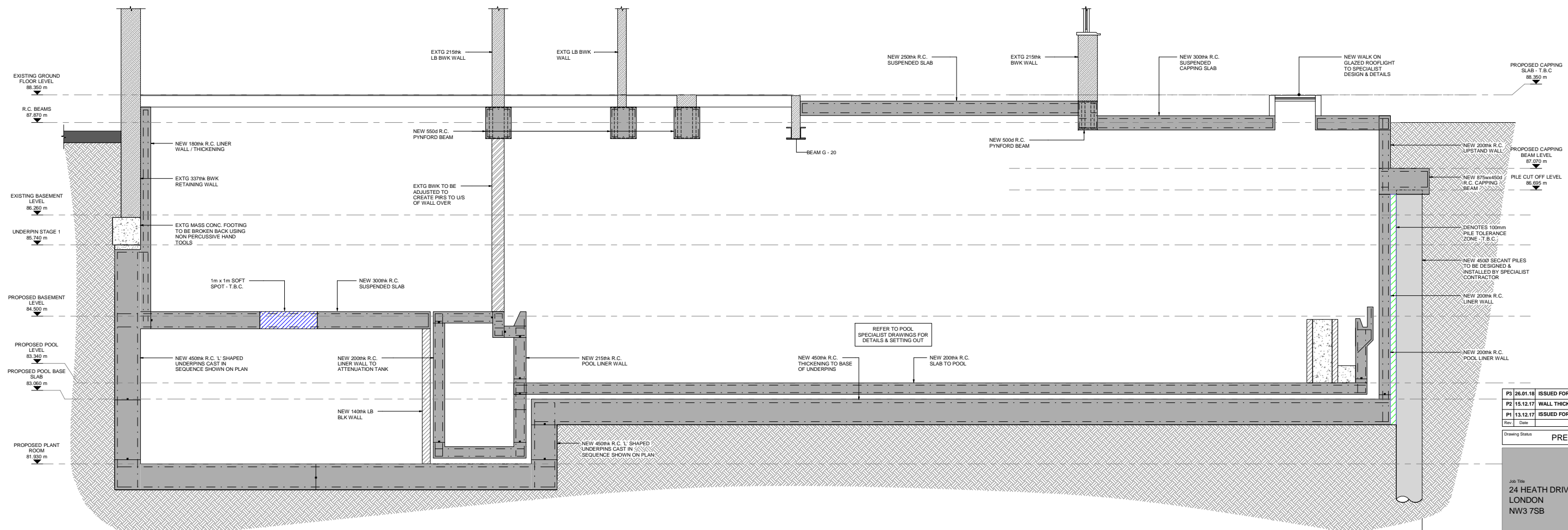

PROPOSED CROSS SECTION F - F
 1:25

Rev	Date	Amendment	Drawn	Checkd
P3	26.01.18	ISSUED FOR PLANNING	P.E.	C.M.
P2	15.12.17	WALL THICKENING ADDED	P.E.	C.M.
P1	13.12.17	ISSUED FOR PLANNING	P.E.	C.M.

Drawing Status: PRELIMINARY

Form

Job Title:
 24 HEATH DRIVE
 LONDON
 NW3 7SB

Drawing Title:
 PROPOSED CROSS SECTIONS E - E & F - F

Form Structural Design Ltd 77 St John Street London EC1M 4BN
 T:020 7253 2893 E:studio@form-sd.com W:www.form-sd.com

Date	Scale	Drawn	Checked
DEC 17	1:25	P.E.	C.M.
Job No:	Drawing No:	Revision	
162637-	A(28)03	P3	

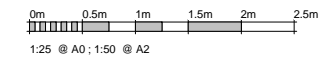

Notes
 THIS DRAWING IS COPYRIGHT OF FORM.
 DO NOT SCALE FROM THIS DRAWING WORK ONLY TO FIGURED DIMENSIONS.
 THE CONTRACTOR IS TO VERIFY ALL DIMENSIONS ON SITE BEFORE COMMENCING WORK. ALL ERRORS AND OMISSIONS ARE TO BE REPORTED TO THE ENGINEER.
 THIS DRAWING IS TO BE READ IN CONJUNCTION WITH ALL RELEVANT ARCHITECTS, SERVICES ENGINEERS AND ENGINEERS DRAWINGS AND SPECIFICATIONS.

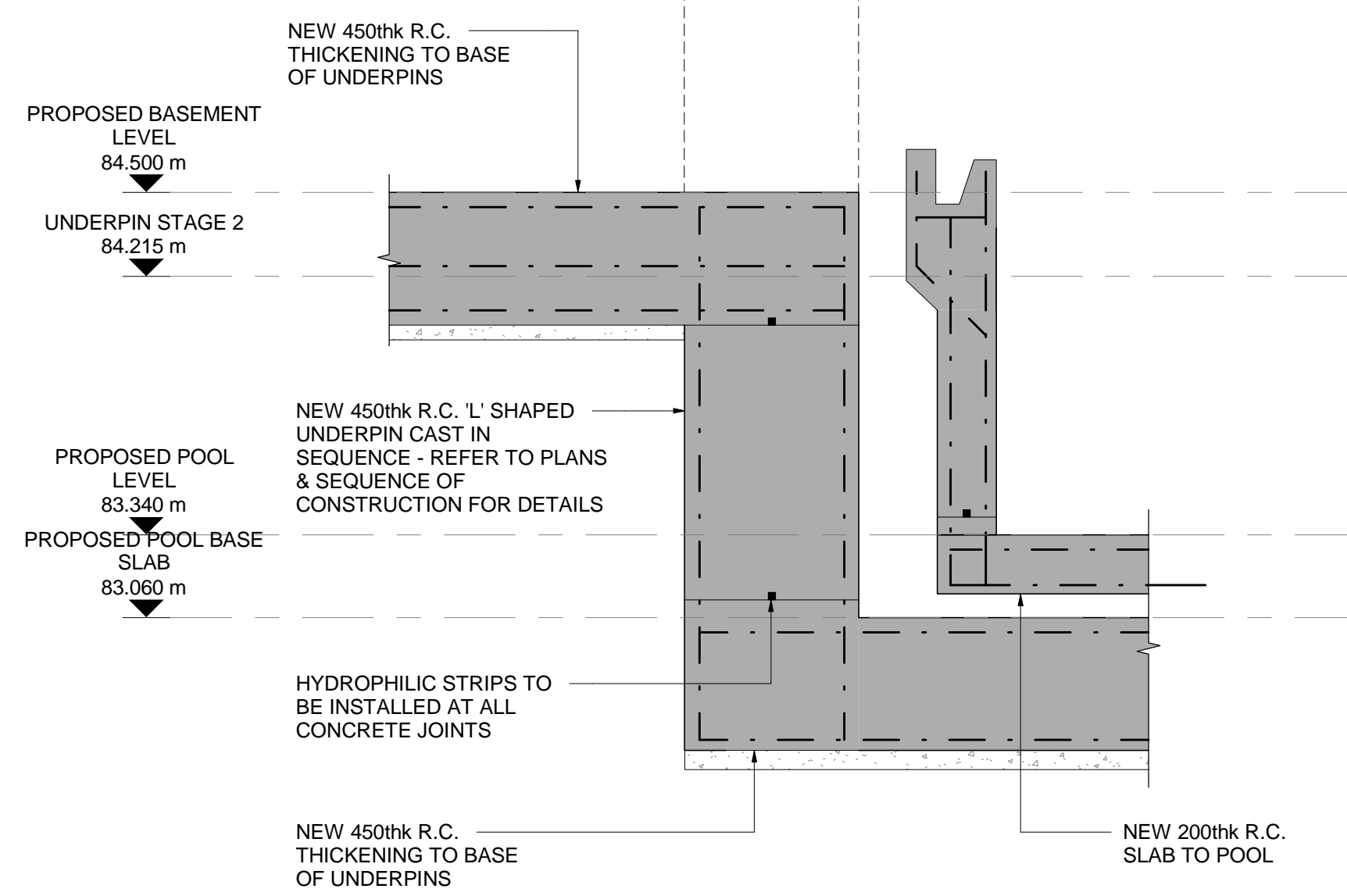
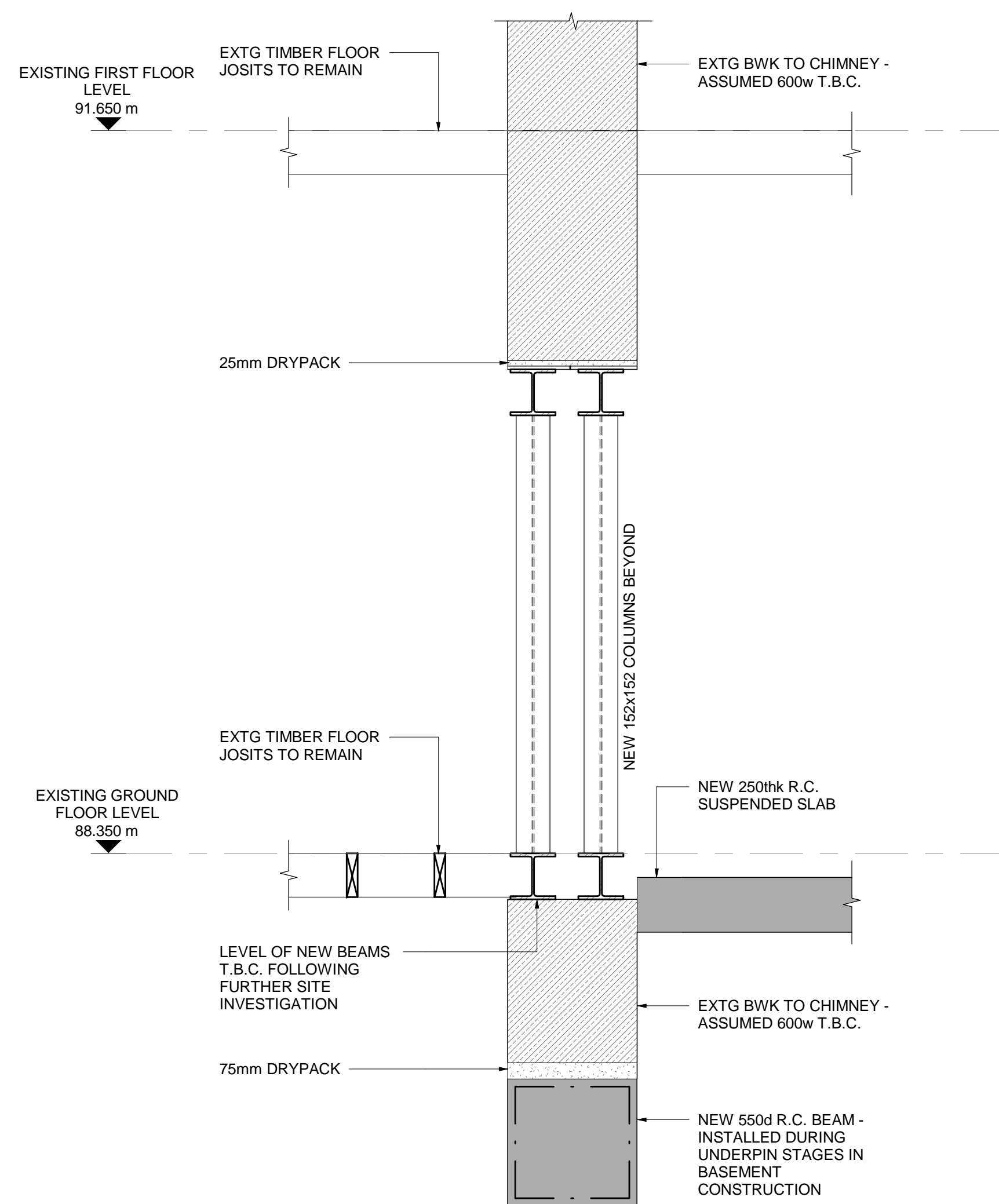

PROPOSED SECTION 01
 1 : 20

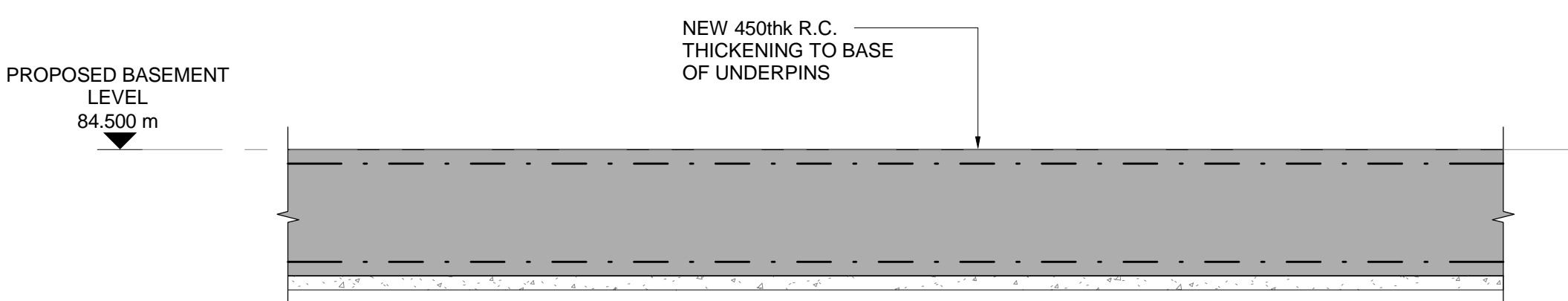
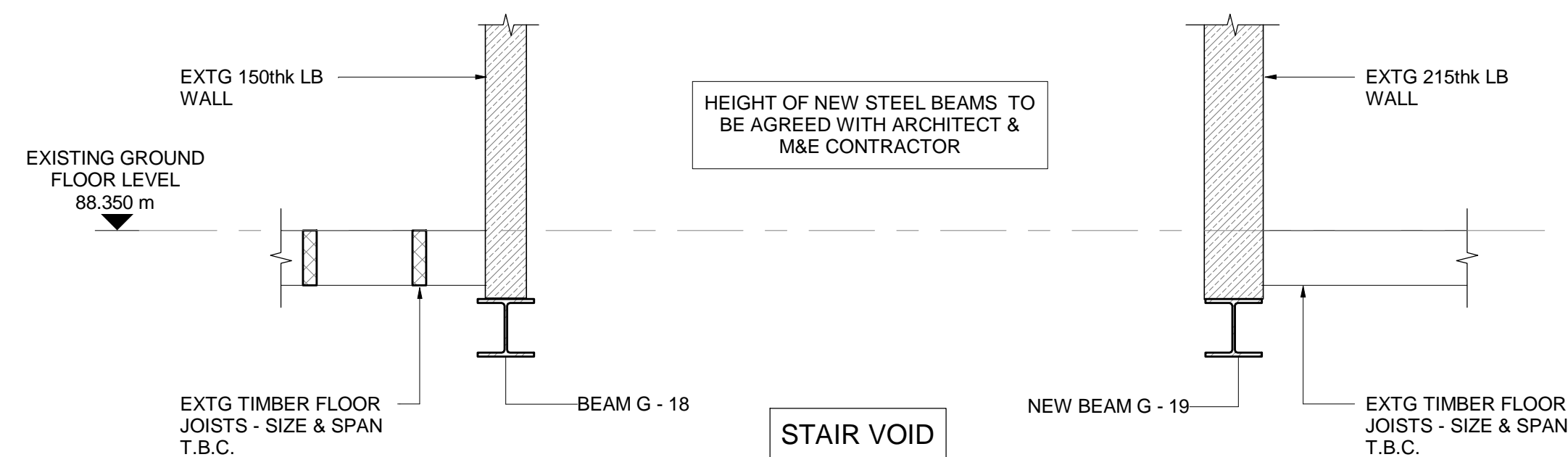

PROPOSED SECTION 02
 1 : 20

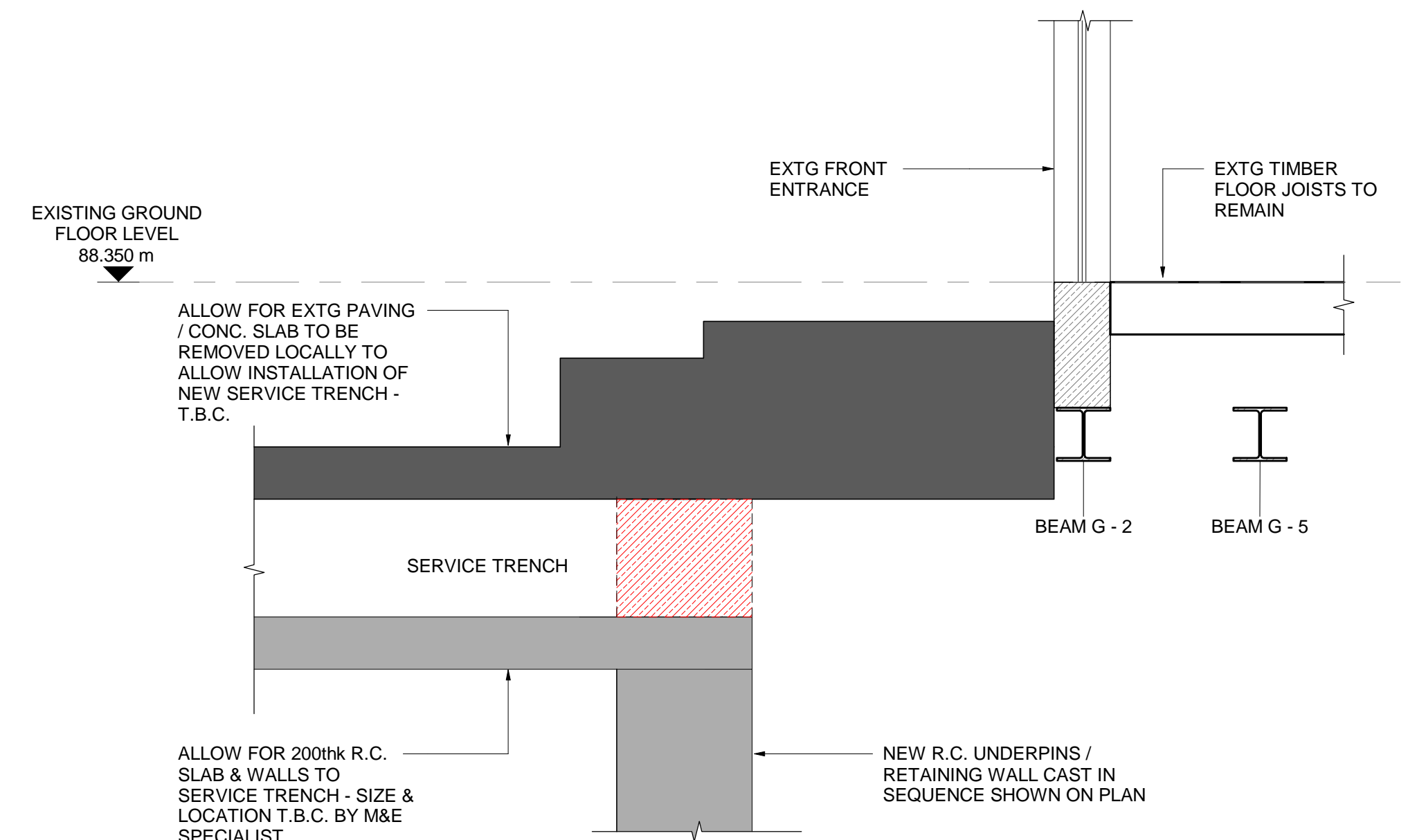

PROPOSED SECTION 03
 1 : 20

P2	29.01.18	SECTION 03 ADDED	P.E	C.M
P1	26.01.18	ISSUED FOR PLANNING	P.E	C.M
Rev.	Date	Amendment	Drawn	Chkd

Drawing Status: **PRELIMINARY**

Form

Job Title
**24 HEATH DRIVE
 LONDON
 NW3 7SB**

Drawing Title
**PROPOSED SECTIONS & DETAILS -
 LOWER LEVELS**

Form Structural Design Ltd 77 St John Street London EC1M 4NN
 T:020 7253 2893 E:studio@form-sd.com W:www.form-sd.com

Date	Scale	Drawn	Checked
JAN 18	1 : 20	P.E	C.M
Job No.	Drawing No.	Revision	
162637	A(23)01	P2	

Notes
 THIS DRAWING IS COPYRIGHT OF FORM.
 DO NOT SCALE FROM THIS DRAWING WORK ONLY TO FIGURED DIMENSIONS.
 THE CONTRACTOR IS TO VERIFY ALL DIMENSIONS ON SITE BEFORE COMMENCING WORK. ALL ERRORS AND OMISSIONS ARE TO BE REPORTED TO THE ENGINEER.
 THIS DRAWING IS TO BE READ IN CONJUNCTION WITH ALL RELEVANT ARCHITECTS, SERVICES ENGINEERS AND ENGINEERS DRAWINGS AND SPECIFICATIONS.

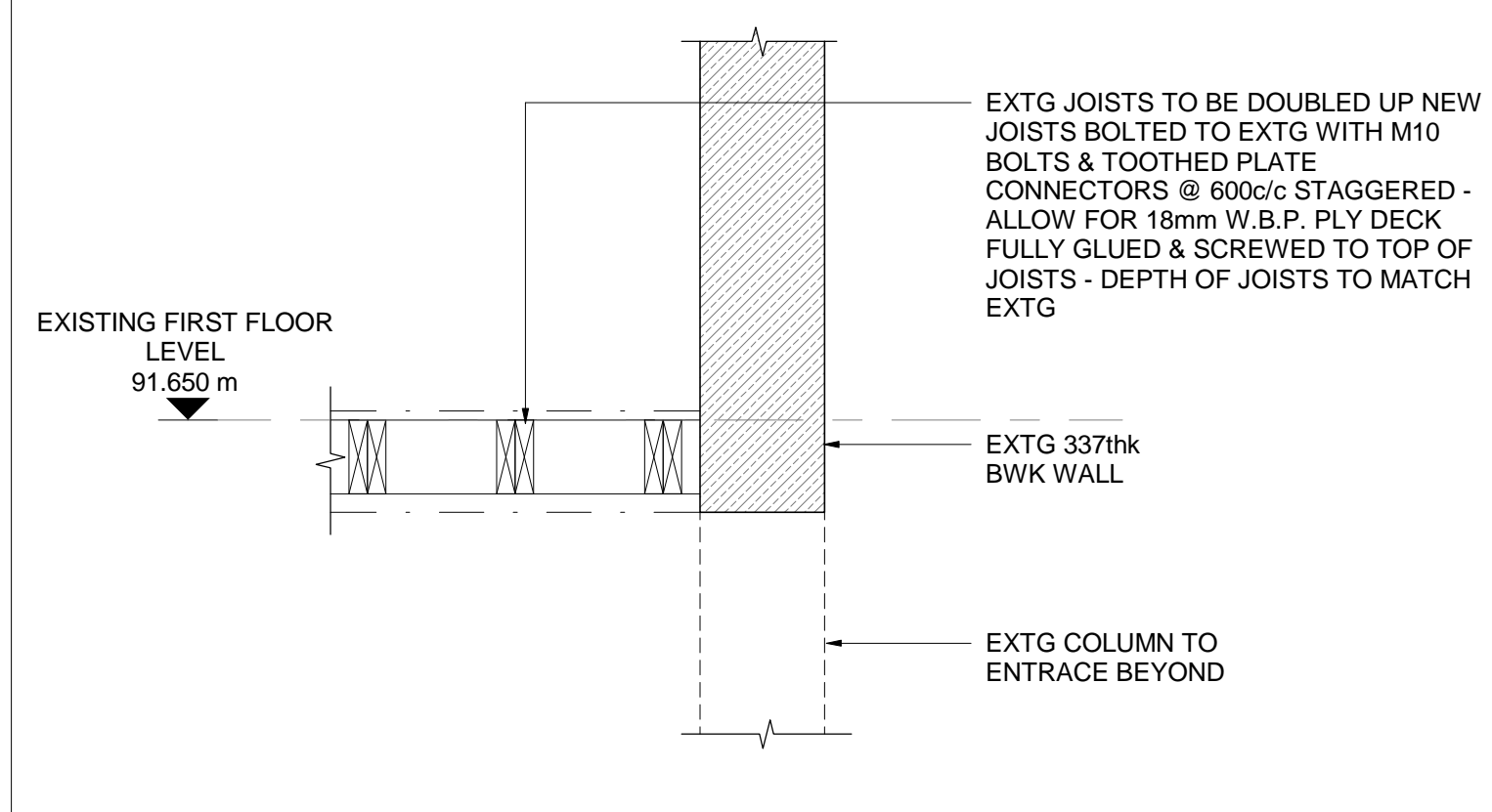

PROPOSED SECTION 04
 1:20

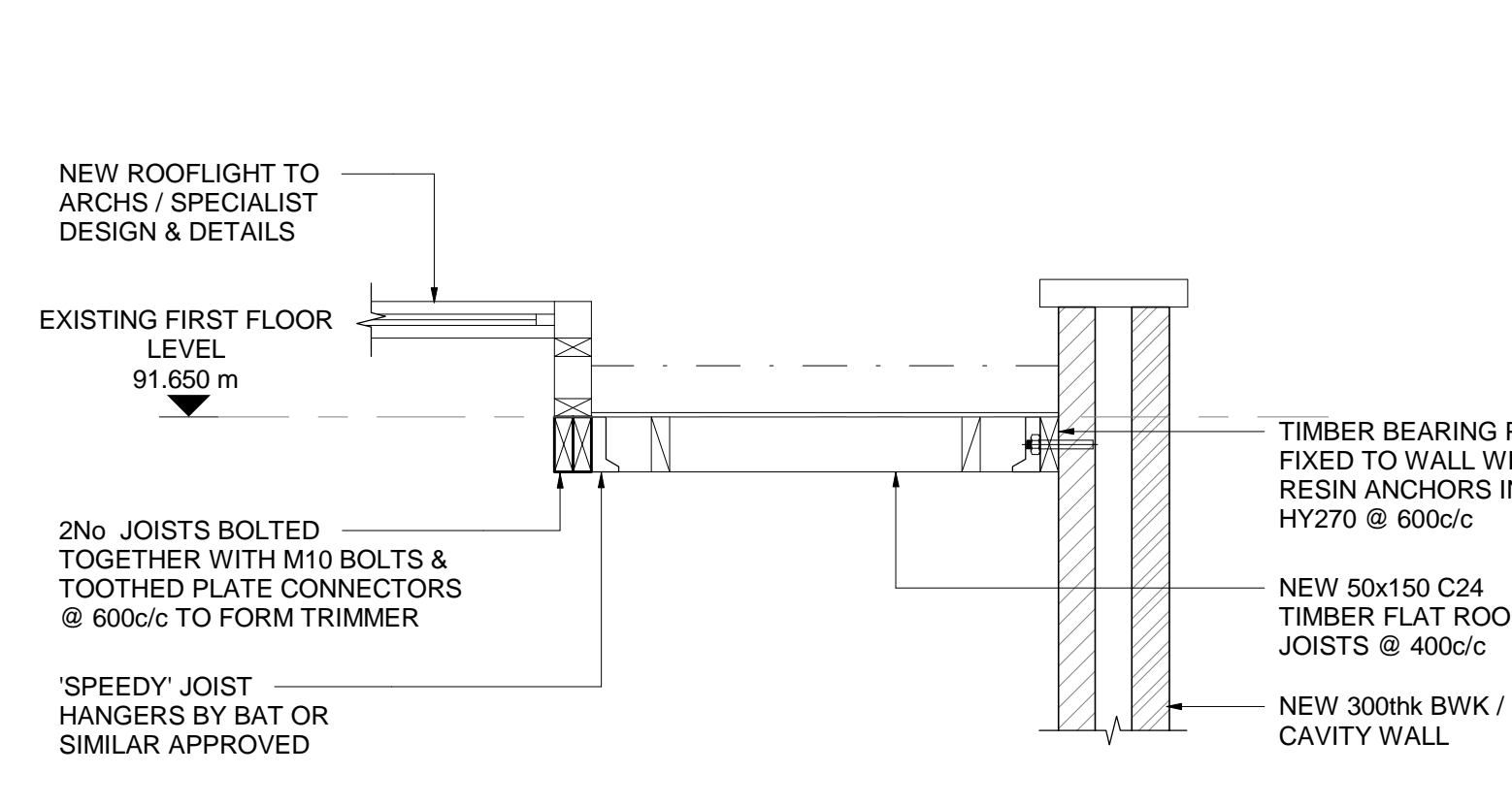

PROPOSED SECTION 05
 1:20

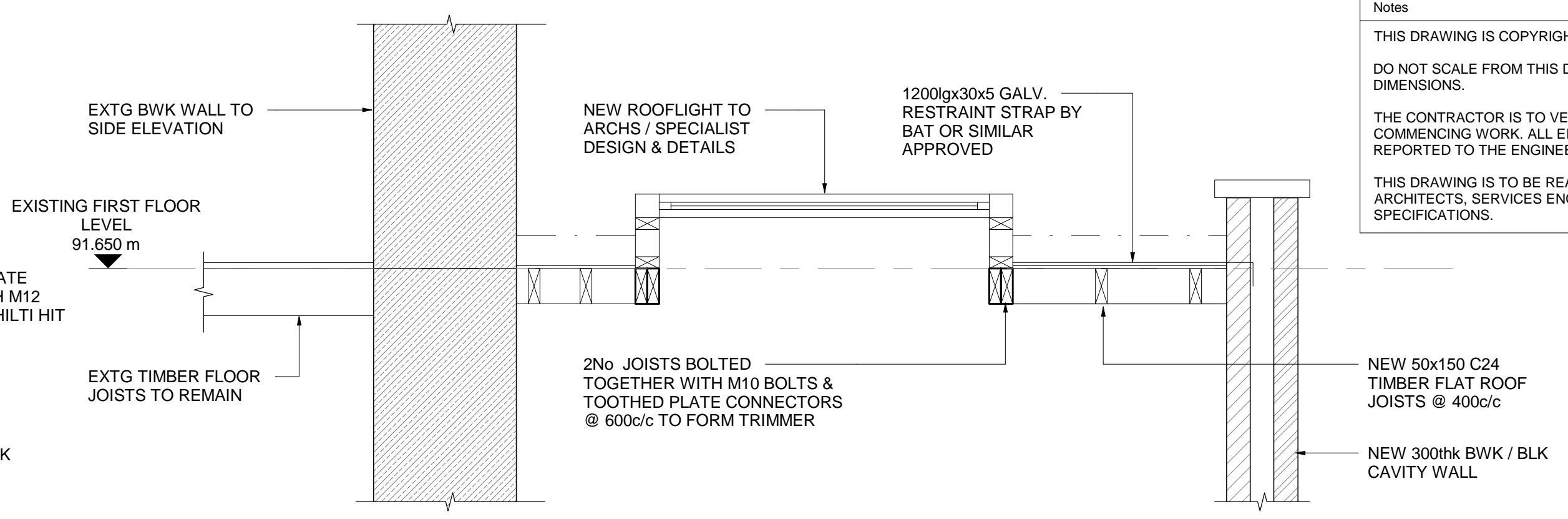

PROPOSED SECTION 06
 1:20

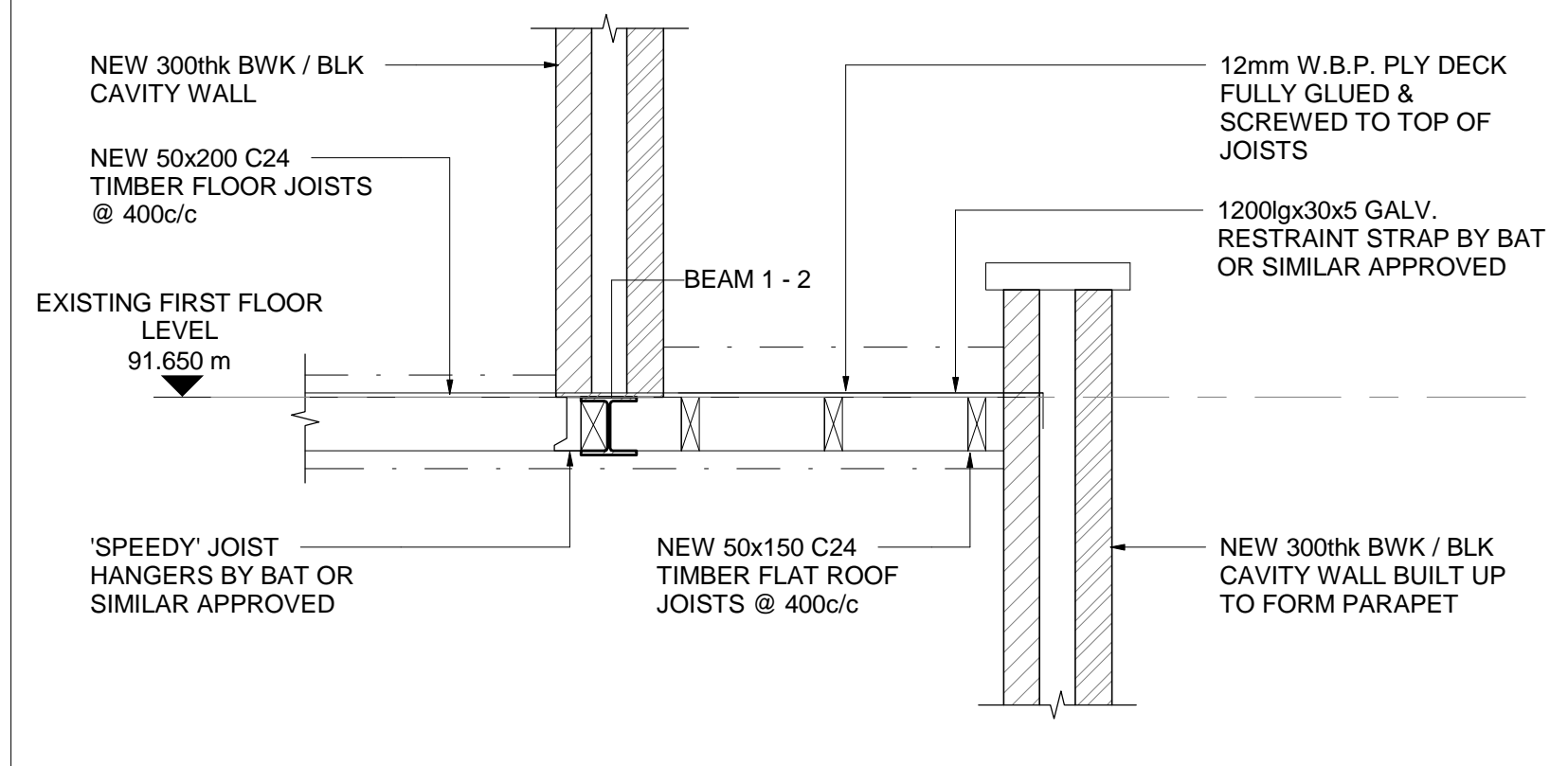

PROPOSED SECTION 07
 1:20

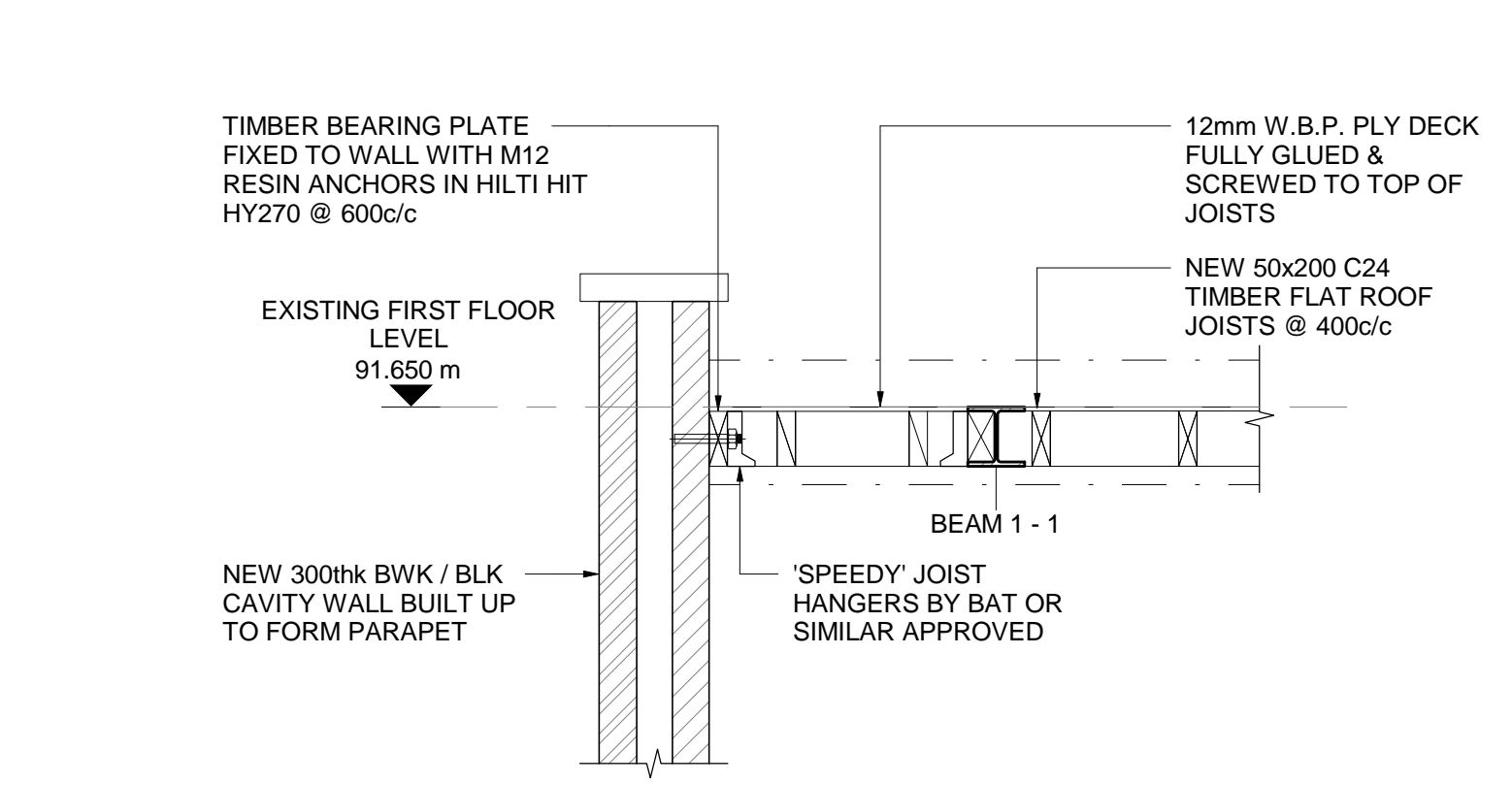

PROPOSED SECTION 08
 1:20

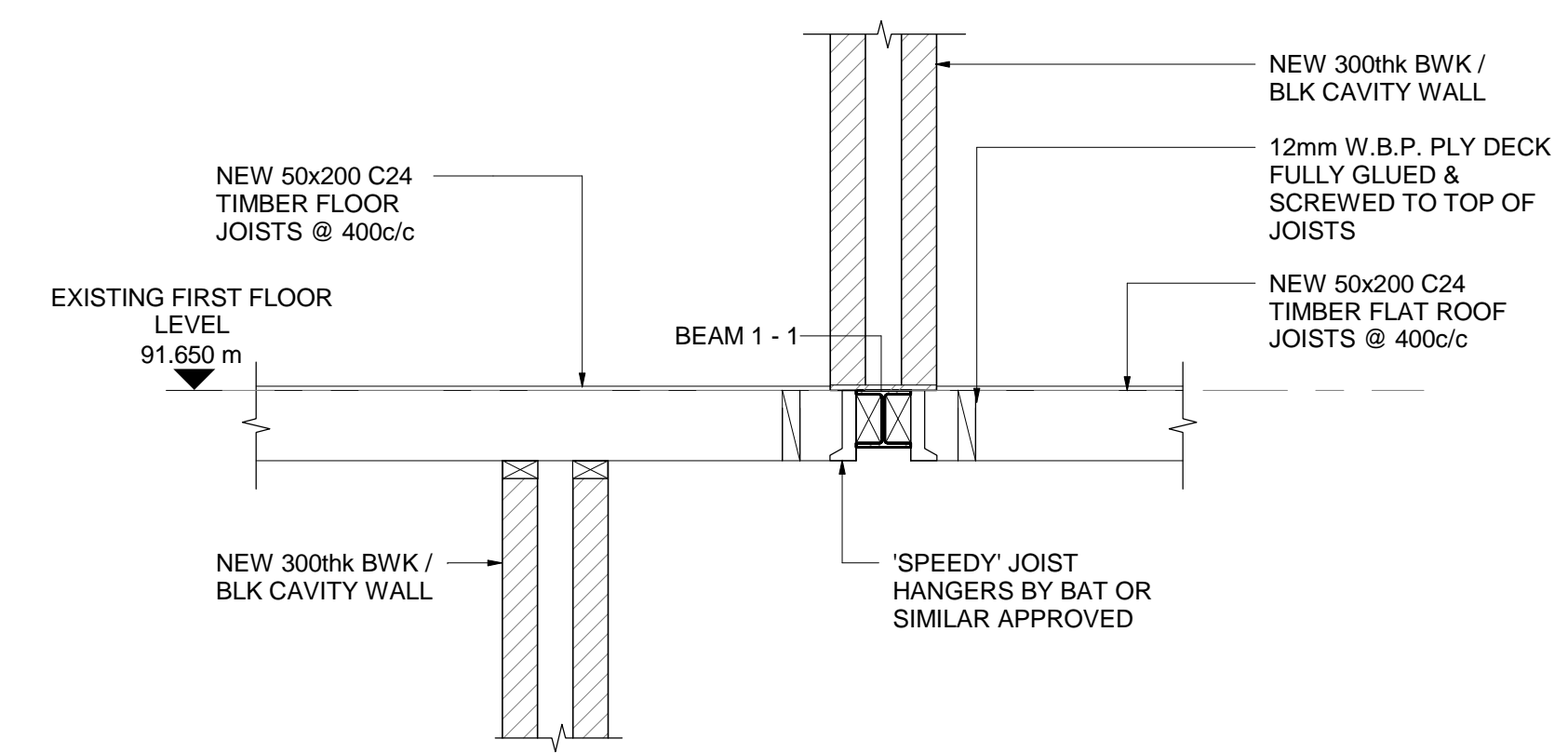

PROPOSED SECTION 09
 1:20

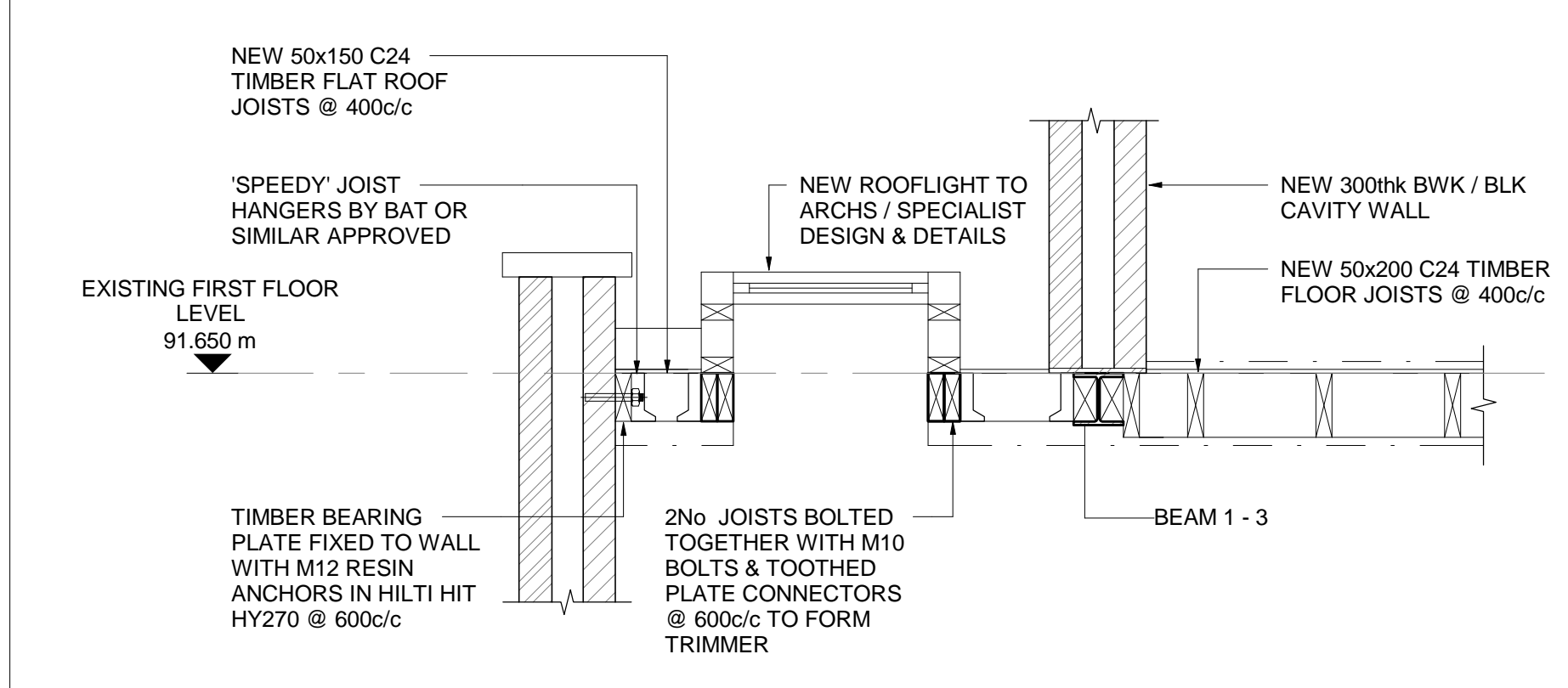

PROPOSED SECTION 10
 1:20

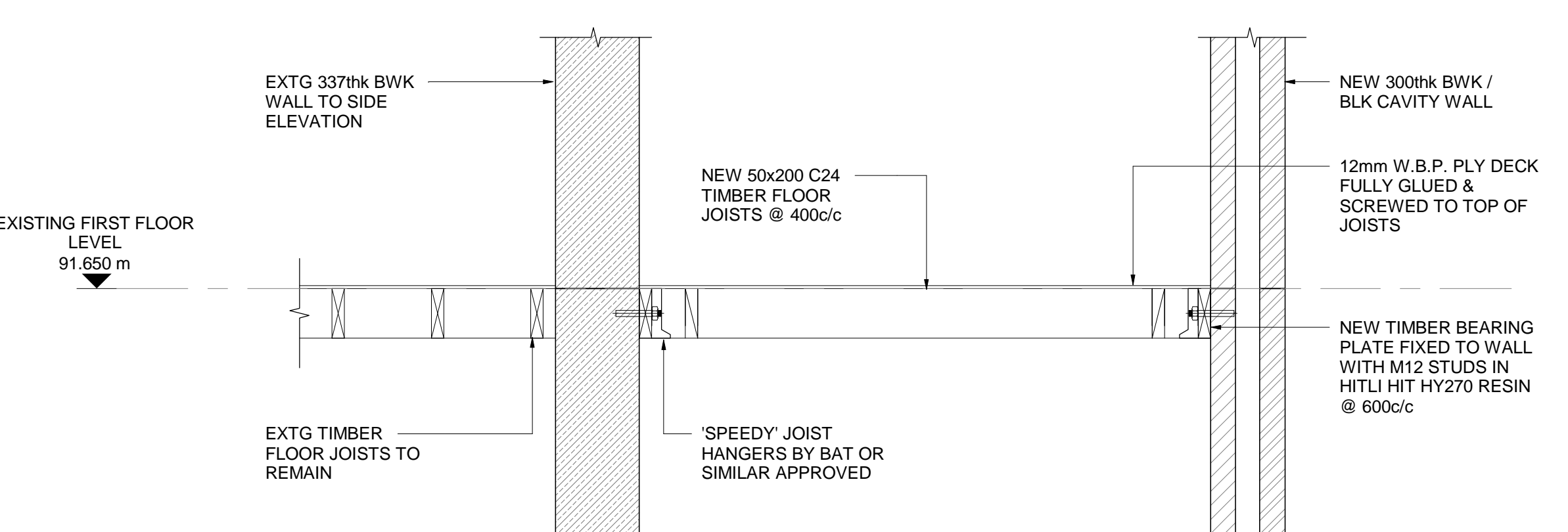

PROPOSED SECTION 11
 1:20

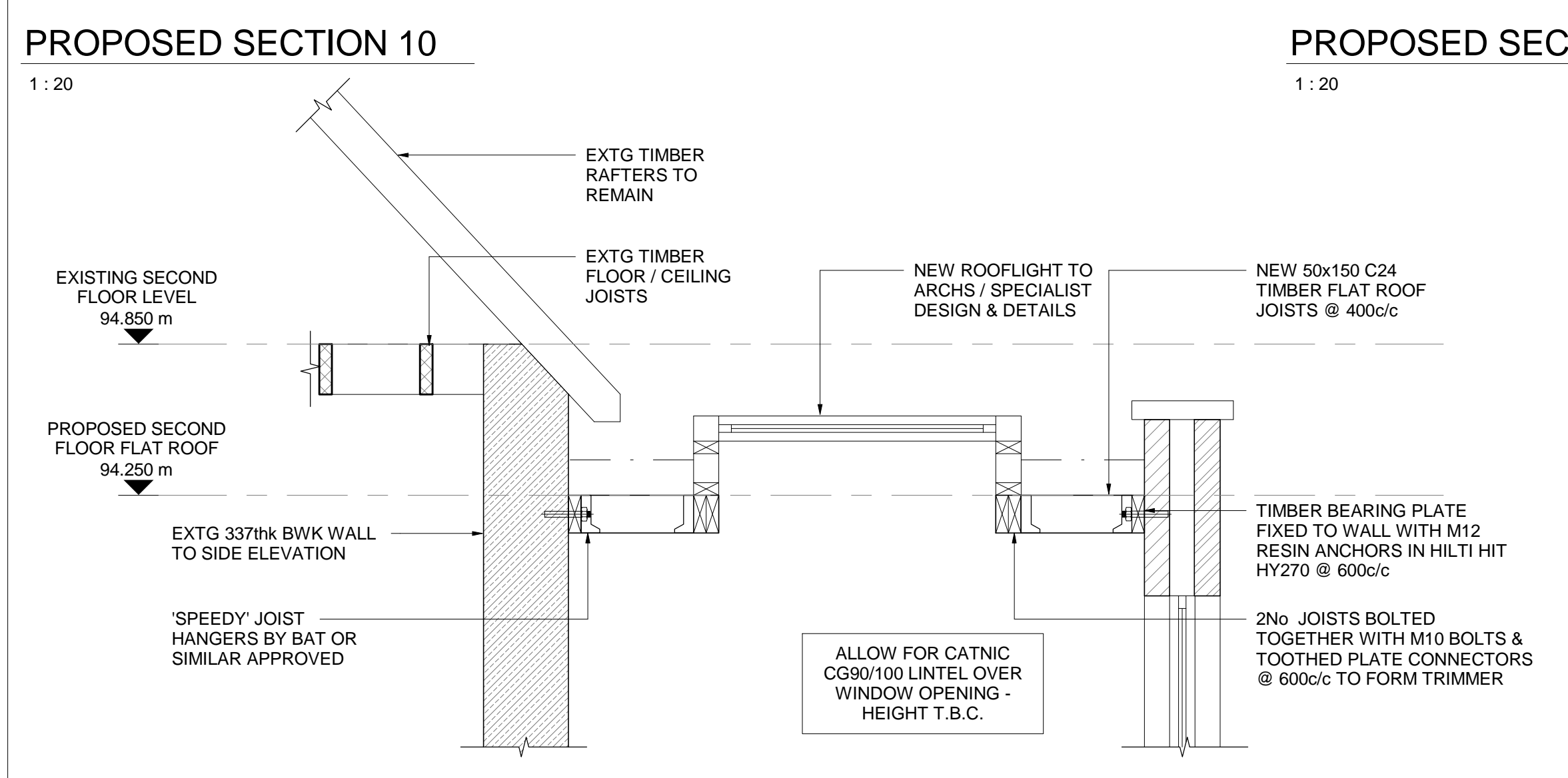

PROPOSED SECTION 12
 1:20

P1	29.01.18	ISSUED FOR PLANNING	P.E	C.M
Rev.	Date	Amendment	Drawn	Chkd

Drawing Status: **PRELIMINARY**

Form

Job Title
**24 HEATH DRIVE
 LONDON
 NW3 7SB**

Drawing Title
**PROPOSED UPPER FLOOR
 SECTIONS & DETAILS**

Form Structural Design Ltd 77 St John Street London EC1M 4NN
 T:020 7253 2893 E:studio@form-sd.com W:www.form-sd.com

Date	Scale	Drawn	Checked
JAN 18	1:20	P.E	C.M
Job No.	Drawing No.	Revision	
162637	A(23)02	P1	