

Notes:

Do not scale this drawing.
 All welds to be 6mm continuous F/W unless noted otherwise.
 All burs & sharp edges removed prior to finish.
 Corrosion Classification & Risk
 Steelwork to BS EN ISO 12944-2
 C1 - Very Low
 C2 - Low
 C3 - Medium
 C4 - High
 All steel to be S275JR to standards
 Open sections to BSEN10025
 Hollow sections (H01) to BSEN10210
 Hollow sections (C04) to BSEN10219
 Plates to BSEN10025.
 Welding to BSEN15614-1,
 Tolerances to BSEN1090-2 appex D
 Execution Class 2 to BSEN1090-1
 Steel parts Stamped or tagged nos if required.
 Dimensions in metric unless stated.
 Drawings checked & signed prior to Fabrication.

3no / OFF

All Face welds to be Ground / Flush

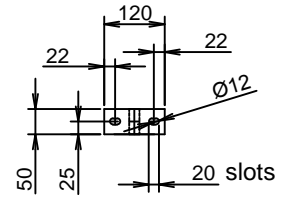
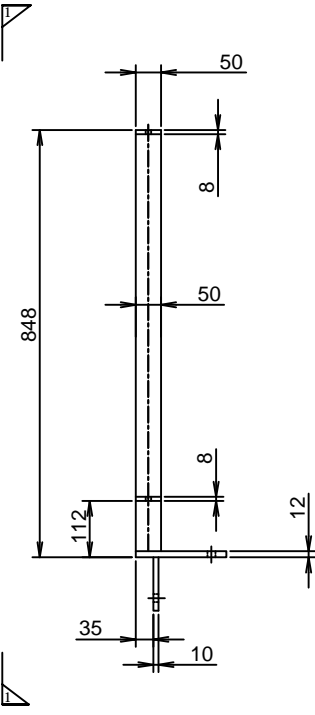

VIEW 4-4

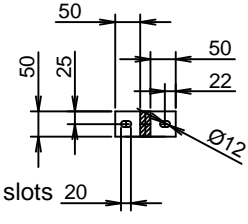

VIEW 3-3

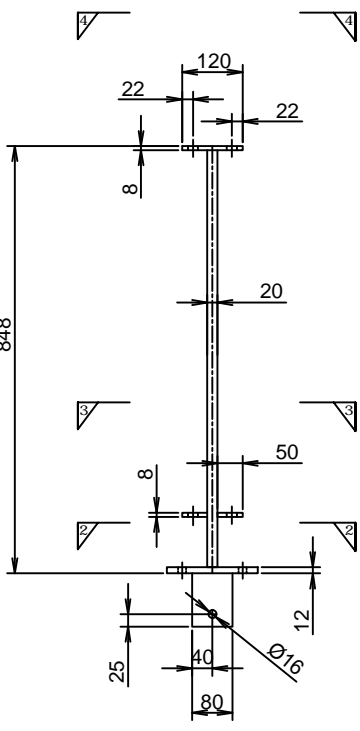

VIEW 1-1

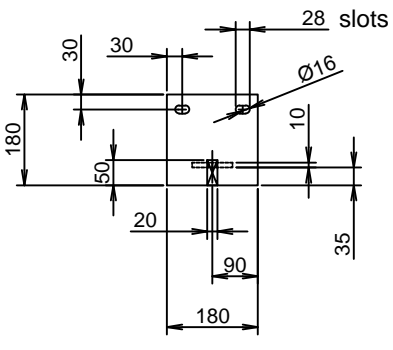

VIEW 2-2

WELDS:
 4mm / Profile Fillets

FINISH:
 Structure/Galv BS1461
 Powder Coat
 Colour : Anodic Bronze

PT	Issued for Approval		
ISSUE	REVISION	DRAWN	DATE
STATUS	construction		

Ardmore
 CONSTRUCTION LTD

Paddington
 CONSTRUCTION LTD.

116 Minerva Lane
 Brimsdown
 Luton LU28 3JG
 EN9 7XE
 E-mail: paddington@ardmoregroup.co.uk

CLIENT
 Ardmore Construction

CONTRACT TITLE
 Parker - House

DRAWING TITLE
 External Terrace Balustrade
 Standard / Sample / Sections

ARCHITECT
 Robin Partridge & Partners
 Architects

Scale	See A3	Job No.	1011
Drawn	BDT	Dwg No.	1011-1-SK-6
Date	20.12.17	Rev. No.	C1
Checked	B.T		