

Location Plan  
1 Bedford Square  
London WC1B 1RB  
SCALE 1:500 @ A4

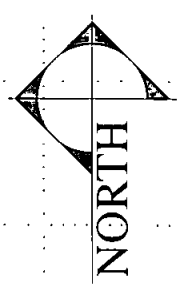

British Museum

**PLANS APPROVED**

14 MAR 2011

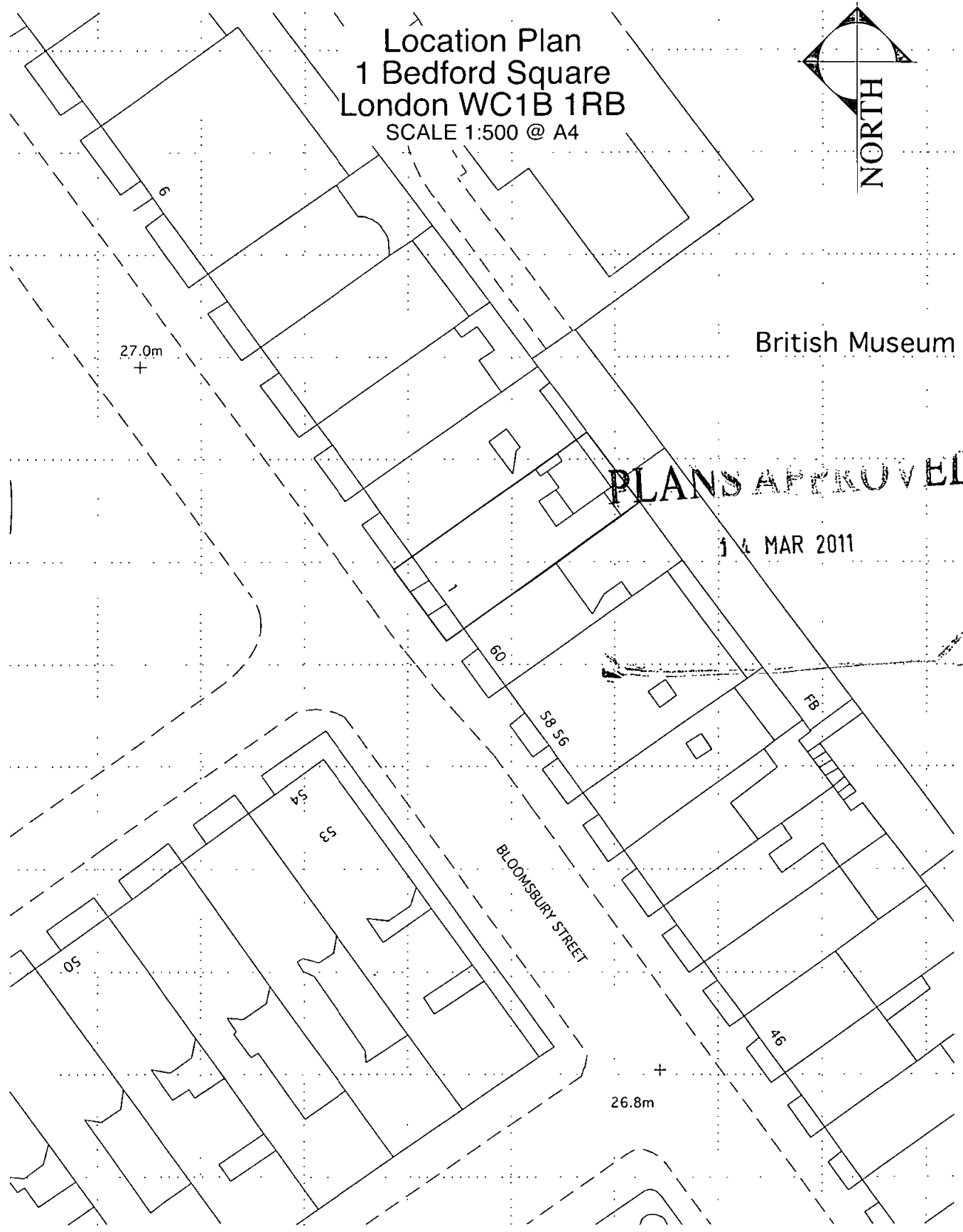

Ordnance Survey (c) Crown Copyright 2010. All rights reserved. Licence number 100020449

**FILE COPY**  
**2010/5978/L**

COPYRIGHT : THE COPYRIGHT OF THIS DRAWING IS VESTED IN CLANCY CONSULTING. IT SHALL NOT BE USED WITHOUT PERMISSION BY ANYONE FOR ANY PURPOSE. DO NOT SCALE THIS DRAWING ELECTRONICALLY OR MANUALLY. WORK TO FIGURED DIMENSIONS ONLY. ALL DIMENSIONS ARE IN MILLIMETRES UNLESS STATED OTHERWISE. THIS DRAWING IS TO BE READ IN CONJUNCTION WITH ALL OTHER ENGINEER'S & ARCHITECT'S DRAWINGS & SPECIFICATIONS

**NOTES**

- DO NOT SCALE, IF IN DOUBT ASK.
- THIS DRAWING IS TO BE READ IN CONJUNCTION WITH ALL RELEVANT STRUCTURAL ENGINEER'S DRAWINGS AND DETAILS, THE SPECIFICATION FOR THE WORKS, THE RELEVANT ARCHITECT'S DRAWINGS AND ANY OTHER SPECIALIST'S DRAWINGS.
- .

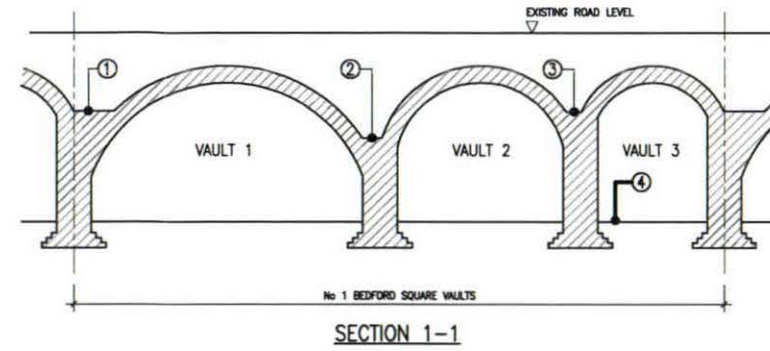
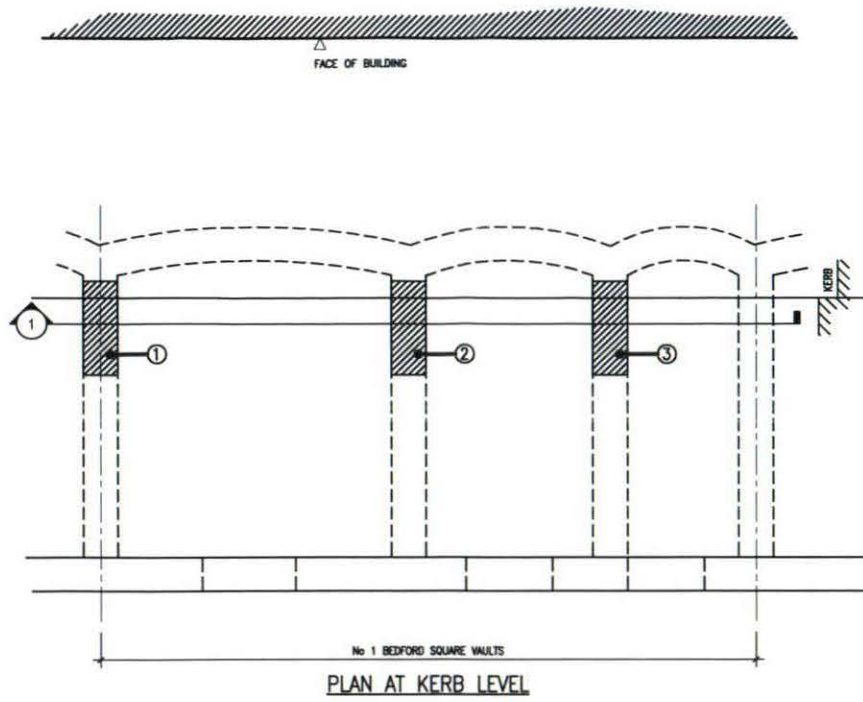

- PRIOR TO CONSTRUCTION OF ANY OF THE VAULT ARCH PROTECTION OR SUPPORT, INSPECTION AT LOCATION 1 TO 4 IS REQUIRED. THESE AREAS WILL BE OPENED UP AS ONE OF THE EARLY STAGES OF WORK, AND IT IS INTENDED INSPECTION IS CARRIED OUT AS WORK PROCEEDS AND NOT AS PRE CONSTRUCTION INVESTIGATION WORKS.
- TO ALLOW INSPECTION OF THE ARCH SPRINGING POINT FOR LEVEL AND CONDITION
  - TO ALLOW INSPECTION OF THE ARCH SPRINGING POINT FOR LEVEL AND CONDITION
  - TO ALLOW INSPECTION OF THE ARCH SPRINGING POINT FOR LEVEL AND CONDITION
  - TO ALLOW INSPECTION OF THE VAULT WALL FOUNDATION AND NEW CONSTRUCTION BEARING

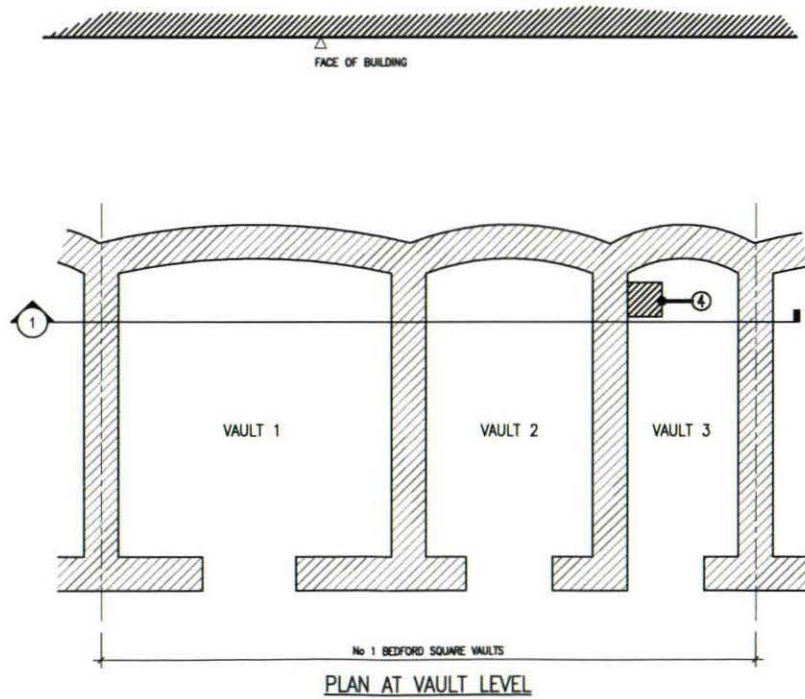

PLANS APPROVED

14 MAR 2011

**TENDER DRAWING**  
THIS DRAWING IS FOR TENDER PURPOSES ONLY AND MUST NOT BE READ AS A CONSTRUCTION ISSUE. IT INDICATES DESIGN INTENT ONLY AND IS SUBJECT TO AMENDMENT DURING FINAL DESIGN DEVELOPMENT

P1	CAE	JL	15.02.11	ISSUED FOR LISTED BUILDING CONSENT
REV.	BY.	CHKD.	DATE	DESCRIPTION
				ENGINEERS SURVEYORS
SARDINIA HOUSE, 52 LINCOLN'S INN FIELDS, LONDON, WC2A 3LZ TEL No. 020 3077 0970 FAX. No. 020 3206 0090				
CLIENT				
PROJECT 1 BEDFORD SQUARE VAULTS				
TITLE AREA REQUIRED FOR EARLY INSPECTION				SCALE 1:50
APPROVED				
JOB No.	2/5021	DRG No.	001	REV. P1 DATE DEC 09
STATUS				PRELIMINARY

A1: J:\Projects\Ingram, L\1\08-2008\3-08-08\2-4810\3-08-08\2-5000-890\3-08-08\2-5021\Drawings\Clancy Drawings\Use Drawings\2-5021-001.dwg, Feb 21 2011 - 12:35pm

COPYRIGHT : THE COPYRIGHT OF THIS DRAWING IS VESTED IN CLANCY CONSULTING. IT SHALL NOT BE USED WITHOUT PERMISSION BY ANYONE FOR ANY PURPOSE. DO NOT SCALE THIS DRAWING ELECTRONICALLY OR MANUALLY. WORK TO FIGURED DIMENSIONS ONLY. ALL DIMENSIONS ARE IN MILLIMETRES UNLESS STATED OTHERWISE. THIS DRAWING IS TO BE READ IN CONJUNCTION WITH ALL OTHER ENGINEER'S & ARCHITECT'S DRAWINGS & SPECIFICATIONS.

- NOTES**
- DO NOT SCALE, IF IN DOUBT ASK.
  - THIS DRAWING IS TO BE READ IN CONJUNCTION WITH ALL RELEVANT STRUCTURAL ENGINEER'S DRAWINGS AND DETAILS, THE SPECIFICATION FOR THE WORKS, THE RELEVANT ARCHITECT'S DRAWINGS AND ANY OTHER SPECIALIST'S DRAWINGS.
  - REINFORCEMENT WEIGHT ASSESSMENT (THE BELOW IS AN ASSESSMENT AND IS SUBJECT TO REVISION FOLLOWING FINAL DESIGN)
    - VAULT 1 - 400kg
    - VAULT 2 - 150kg
    - VAULT 3 - 80kg
  - BAR TYPE T16 & T12

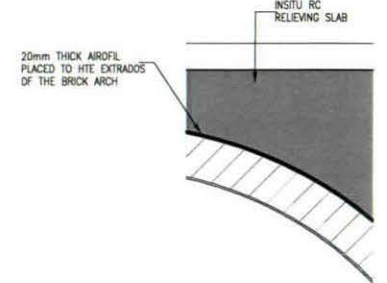
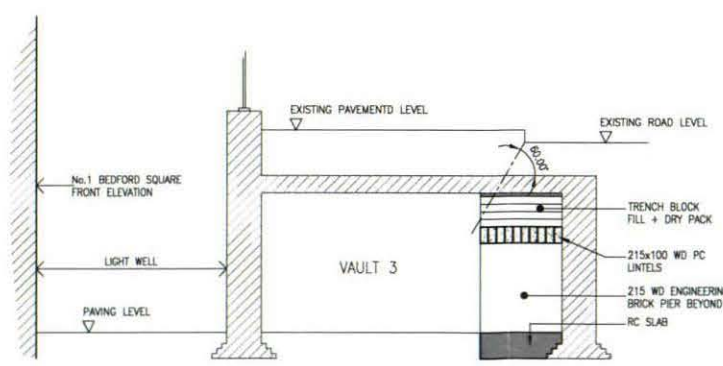
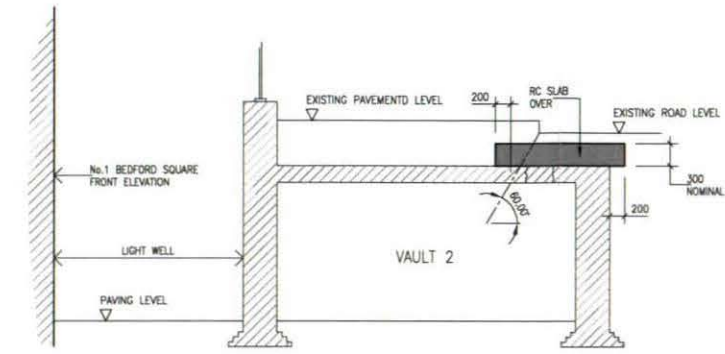
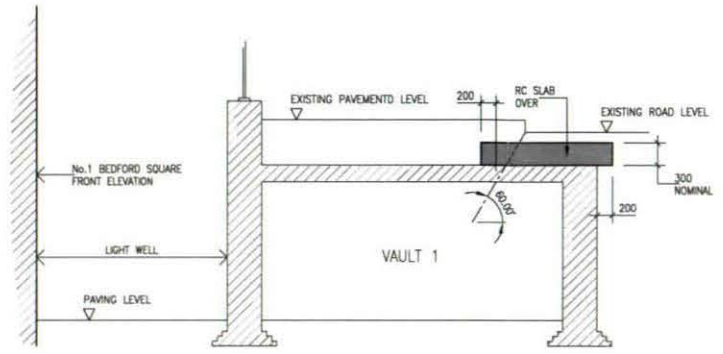
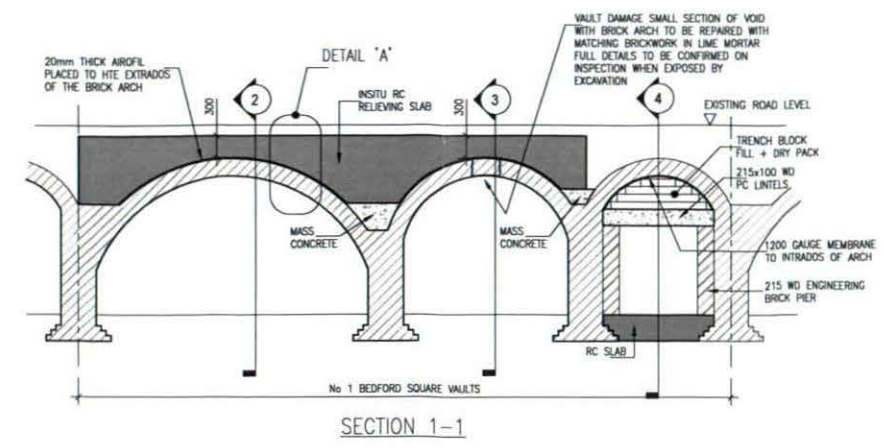
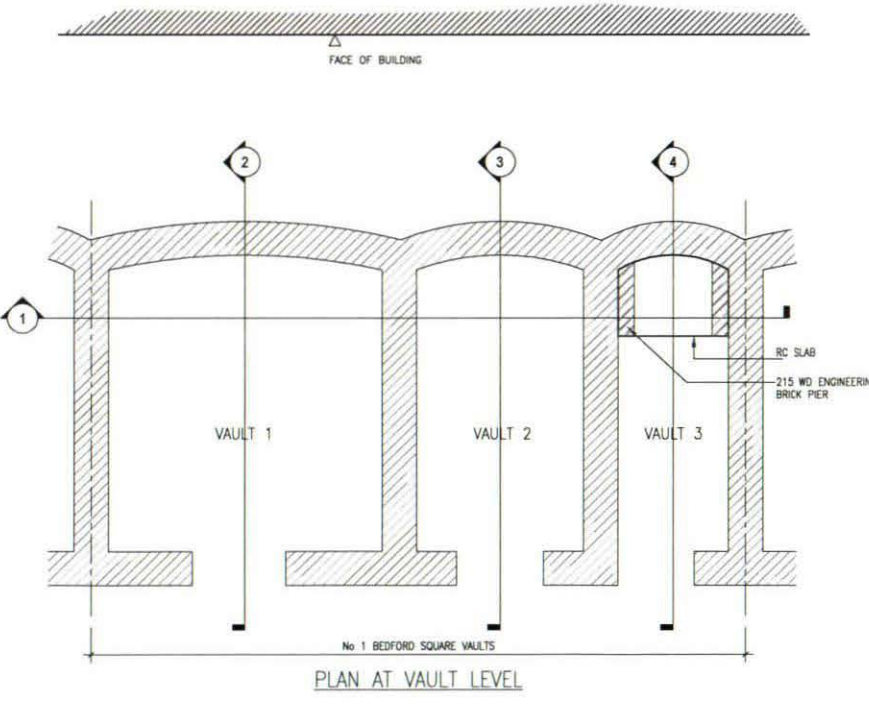
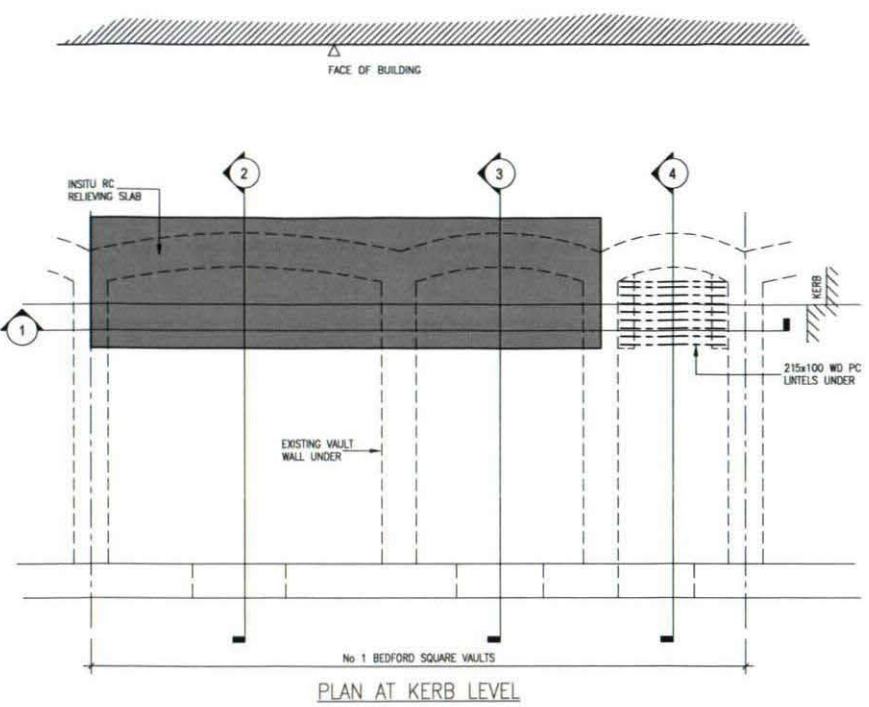

- CONCRETE**
- CONCRETE FOR BLINDING IS TO BE GRADE GEN1.
  - MASS CONCRETE TO BE GRADE FND3.
  - REINFORCED CONCRETE GRADE TO BE RC40.
  - ALL ABOVE IN ACCORDANCE WITH BS 8500
  - CONCRETE WITHIN VAULT 2 TO BE PLACED IN A MINIMUM OF 2 POURS WITH THE UPPER POUR FILLING THE DAMAGED BRICK ARCH RING TO THE UPPER SURFACE OF THE BRICK ARCH.
  - SHUTTERING TO BE BRACED TO THE VAULT SIDE WALLS TO RESIST HYDROSTATIC LOADS.
- REINFORCEMENT**
- ALL REINFORCEMENT TO BE GRADE 460 TYPE 2 UNLESS NOTED OTHERWISE.
  - H DENOTES HIGH YIELD BARS TO B.S. 4449. R DENOTES MILD STEEL BARS TO B.S. 4449.
  - CONCRETE COVER TO BE MAINTAINED BY THE USE OF CONCRETE OR PLASTIC SPACERS, PREWELDED CHAIRS, STOOLS ETC. BROKEN BRICKS OR TILES, ETC MAY NOT BE USED.
- PC LINTELS**
- PC LINTELS TO BE SUPREME CONCRETE R22A OR EQUAL APPROVED
- MASONRY**
- LOADBEARING BLOCKWORK TO HAVE A MINIMUM CHARACTERISTIC COMPRESSIVE STRENGTH OF 10N/mm<sup>2</sup> TO BS 5628 PART 1:1992 UNLESS NOTED OTHERWISE. TO BE TARMAC TRENCH BLOCK OR EQUAL APPROVED.
  - ENGINEERING BRICKS TO HAVE A CHARACTERISTIC COMPRESSIVE STRENGTH OF 50N/mm<sup>2</sup> TO BS 5628 PART 1:1992 UNLESS NOTED OTHERWISE. FURTHER DETAILS TO ARCHITECT'S SPECIFICATION.
  - MORTAR IN LOAD BEARING WALLS TO BE DESIGNATION (I) TO B.S.5628 PART 1:1992
- FOUNDATIONS**
- FOUNDATIONS SHALL BE TAKEN DOWN TO THE SPECIFIED FORMATION IN NATURALLY OCCURRING MATERIAL. THE FORMATION LEVELS SHALL BE INSPECTED BY THE ENGINEER AND THE LOCAL AUTHORITY PRIOR TO CASTING CONCRETE OR LAYING OF HARDCORE.

**PLANS APPROVED**  
14 MAR 2011

**TENDER DRAWING**  
THIS DRAWING IS FOR TENDER PURPOSES ONLY AND MUST NOT BE READ AS A CONSTRUCTION ISSUE. IT INDICATES DESIGN INTENT ONLY AND IS SUBJECT TO AMENDMENT DURING FINAL DESIGN DEVELOPMENT

P1	CAE	JL	15.02.11	ISSUED FOR LISTED BUILDING CONSENT
REV.	BY.	CHKD.	DATE	DESCRIPTION
SARDINIA HOUSE, 52 LINCOLN'S INN FIELDS, LONDON, WC2A 3LZ TEL No. 020 3077 0970 FAX. No. 020 3206 0090				
<b>CLIENT</b>				
<b>PROJECT</b> 1 BEDFORD SQUARE VAULTS				
<b>TITLE</b> AREA REQUIRED FOR EARLY INSPECTION				<b>SCALE</b> 1:50
				<b>APPROVED</b>
<b>JOB No.</b> 2/5021	<b>DRG No.</b> 002	<b>REV.</b> P1	<b>DATE</b>	<b>DEC 09</b>
<b>STATUS</b> PRELIMINARY				

A1: J:\DWG\0851\2-1\DWG\999-2-4910\2-5000-999\2-5021\Drawings\Clancy Drawings\Live Drawings\2-5021-002.dwg, Feb 21 2011 12:45pm

Legend:

 Damaged arch

**PLANS APPROVED**

14 MAR 2011

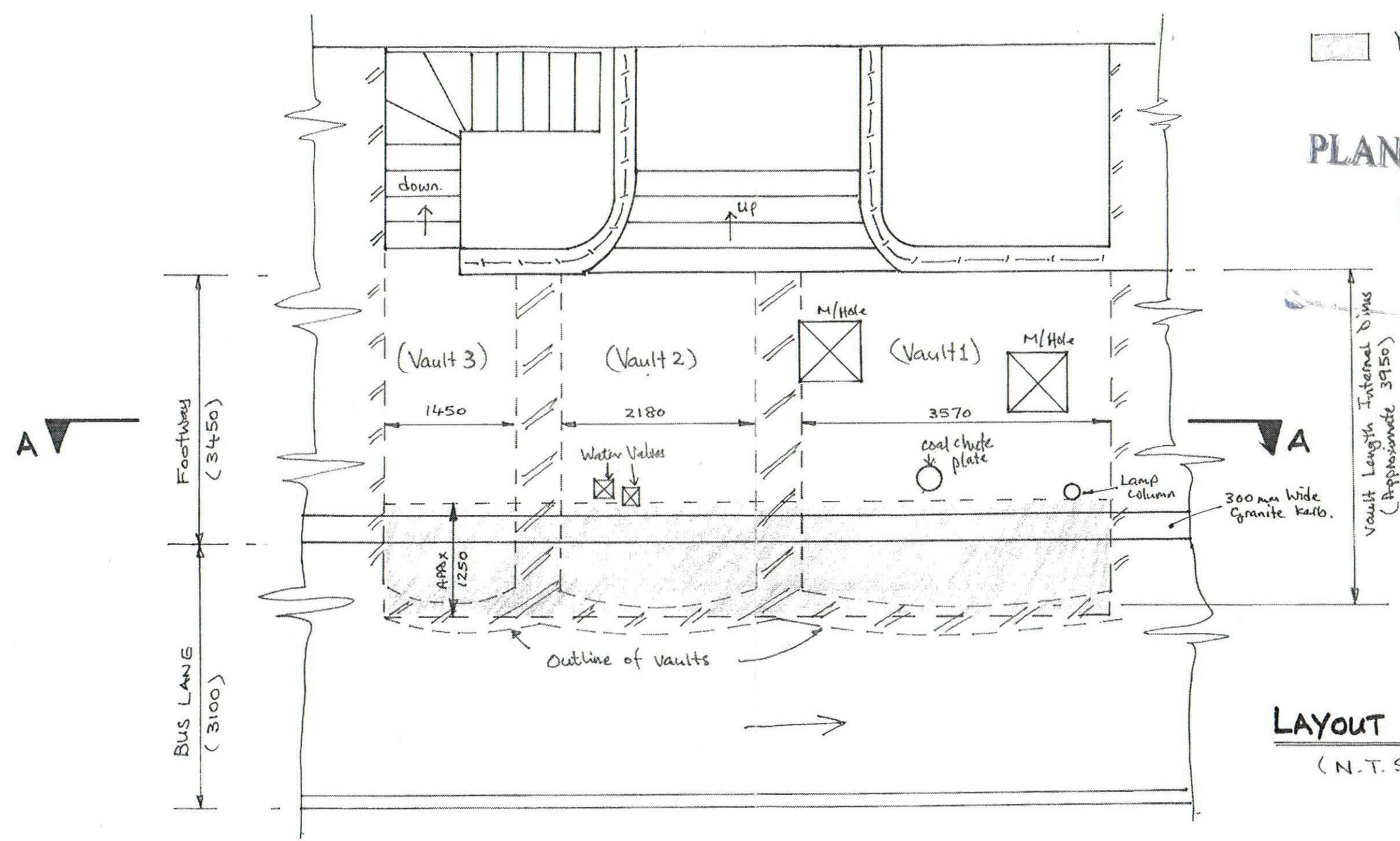

**LAYOUT PLAN**  
(N.T.S.)

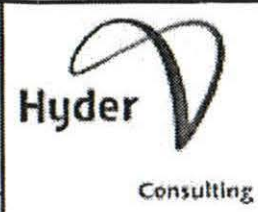
		Project				 HYDER CONSULTING (UK) LIMITED 29 BRESSENDEN PLACE London SW1E 5DZ Tel: +44 (0) 20 7316 6000 Fax: +44 (0) 7316 6125	
		1 BEDFORD SQUARE - ARCH REPAIR				Project Code: WM75000/LN504L/ Drawing No: SK001 Issue:	
Issue	FOR AIP APPROVAL	Auth	DKC	Checked	18 Sept '09	Title	
Scale	DO NOT SCALE	Datum				TEMPORARY WORKS DETAILS	
						SHEET 1 OF 2	

FILE COPY 2010/5978/L

This document has been prepared in accordance with the scope of Scott Wilson's appointment with its client and is subject to the terms of that appointment. Scott Wilson accepts no liability for any use of this document other than by its client and only for the purposes for which it was prepared and provided. Only written dimensions shall be used. © Scott Wilson Group PLC 2008

- NOTE:**
- DO NOT SCALE, IF IN DOUBT ASK.
  - THIS DRAWING IS TO BE READ IN CONJUNCTION WITH ALL RELEVANT STRUCTURAL ENGINEER'S DRAWINGS AND DETAILS, THE SPECIFICATION FOR THE WORKS, THE RELEVANT ARCHITECT'S DRAWINGS AND ANY OTHER SPECIALIST'S DRAWINGS.

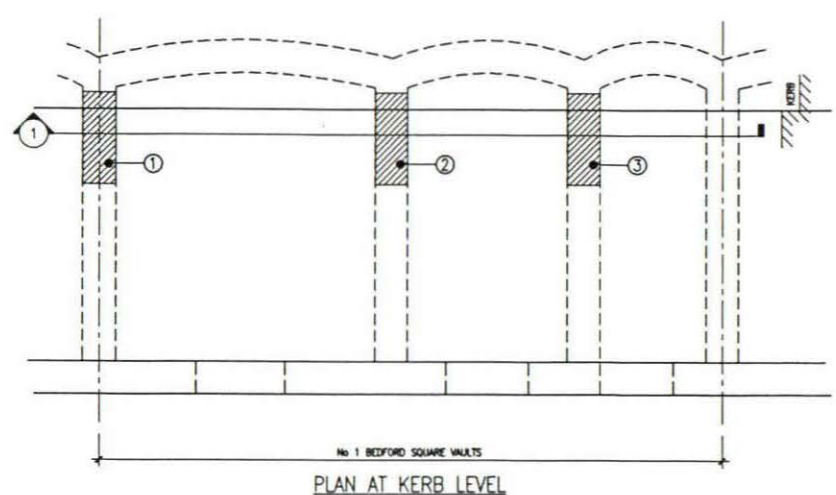

PLAN AT KERB LEVEL

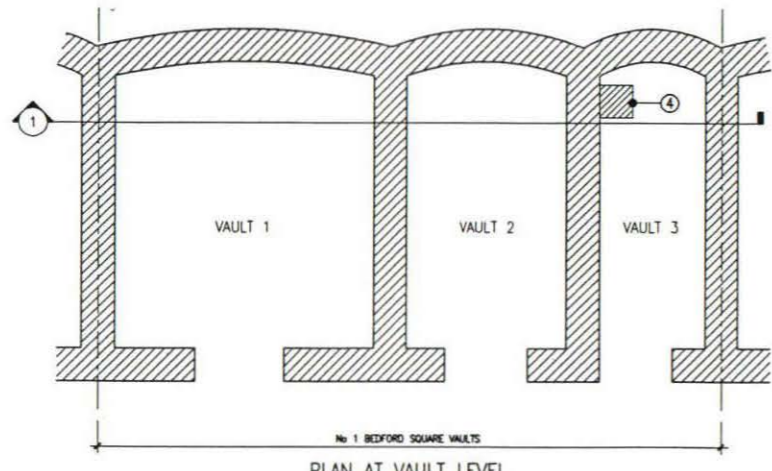

PLAN AT VAULT LEVEL

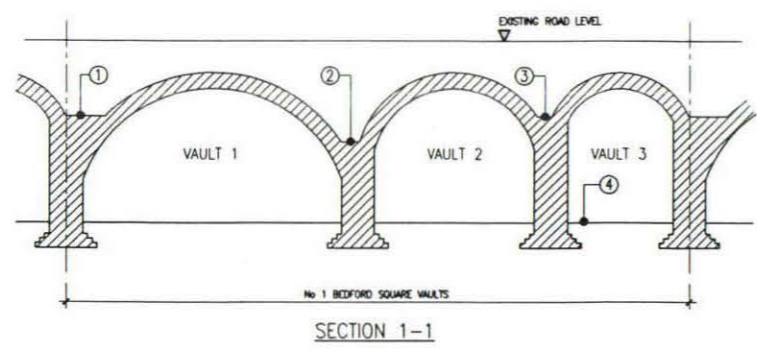

SECTION 1-1

PRIOR TO CONSTRUCTION OF ANY OF THE VAULT ARCH PROTECTION OR SUPPORT, INSPECTION AT LOCATION 1 TO 4 IS REQUIRED. THESE AREAS WILL BE OPENED UP AS ONE OF THE EARLY STAGES OF WORK, AND IT IS INTENDED INSPECTION IS CARRIED OUT AS WORK PROCEEDS AND NOT AS PRE CONSTRUCTION INVESTIGATION WORKS.

- TO ALLOW INSPECTION OF THE ARCH SPRINGING POINT FOR LEVEL AND CONDITION
- TO ALLOW INSPECTION OF THE ARCH SPRINGING POINT FOR LEVEL AND CONDITION
- TO ALLOW INSPECTION OF THE ARCH SPRINGING POINT FOR LEVEL AND CONDITION
- TO ALLOW INSPECTION OF THE VAULT WALL FOUNDATION AND NEW CONSTRUCTION BEARING

*SUPPRESSED*

LOCATION OF INSPECTION POINT 3	DP/A	15/12/09	T2
REVISION			
TENDER ISSUE	DP/A	08/12/09	T1
Revision Details	By	Date	Subs
	Check		

Drawing Status: TENDER

Job Title: 1 BEDFORD SQUARE VAULTS

Drawing Title: AREAS REQUIRED FOR EARLY INSPECTION

Scale at A1	1:50		
Drawn	DP	Approved	JL
Stage 1 check	Stage 2 check	Originated	Date
			DEC'09

Scott Wilson  
 6-8 Grosvenor Place  
 London  
 SW1P 1PL  
 Telephone (020) 7798 5000  
 Fax (020) 7798 5001  
 www.scottwilson.com



Drawing Number: D124263-001 Rev: T2

TENDER DRAWING:  
 THIS DRAWING IS FOR TENDER PURPOSES ONLY AND MUST NOT BE READ AS A CONSTRUCTION ISSUE. IT INDICATES DESIGN INTENT ONLY AND IS SUBJECT TO AMENDMENT DURING FINAL DESIGN DEVELOPMENT.

*FILE COPY 2010/5978/L*

drawings: A:\2009\07\124263\DW\Area\rev04\09.12.15\001\_T2.dwg, Dec 15 2009, 12:11 pm

081V

This document has been prepared in accordance with the scope of Scott Wilson's appointment with its client and is subject to the terms of that appointment. Scott Wilson accepts no liability for any use of this document other than by its client and only for the purposes for which it was prepared and provided. Only written dimensions shall be used. © Scott Wilson Group PLC 2006

- NOTE:**
- DO NOT SCALE, IF IN DOUBT ASK.
  - THIS DRAWING IS TO BE READ IN CONJUNCTION WITH ALL RELEVANT STRUCTURAL ENGINEER'S DRAWINGS AND DETAILS, THE SPECIFICATION FOR THE WORKS, THE RELEVANT ARCHITECT'S DRAWINGS AND ANY OTHER SPECIALIST'S DRAWINGS.
  - REINFORCEMENT WEIGHT ASSESSMENT (THE BELOW IS AN ASSESSMENT AND IS SUBJECT TO REVISION FOLLOWING FINAL DESIGN)
- VAULT 1 - 400kg  
 VAULT 2 - 150kg  
 VAULT 3 - 80kg
- BAR TYPE T16 & T12

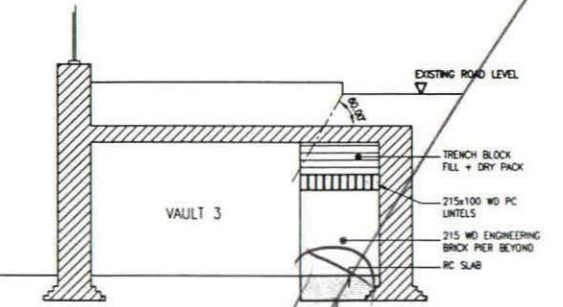
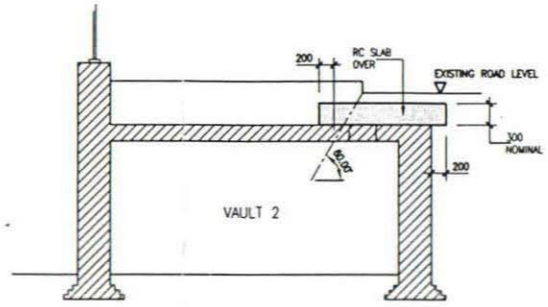
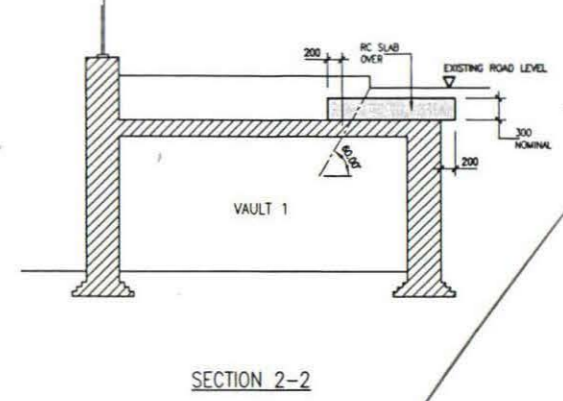
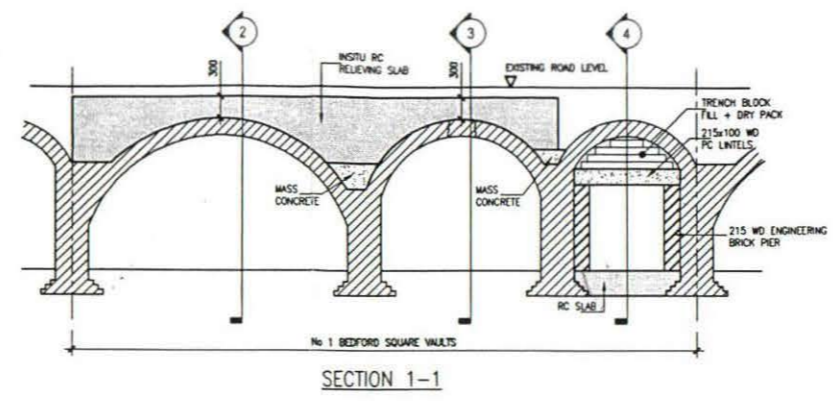
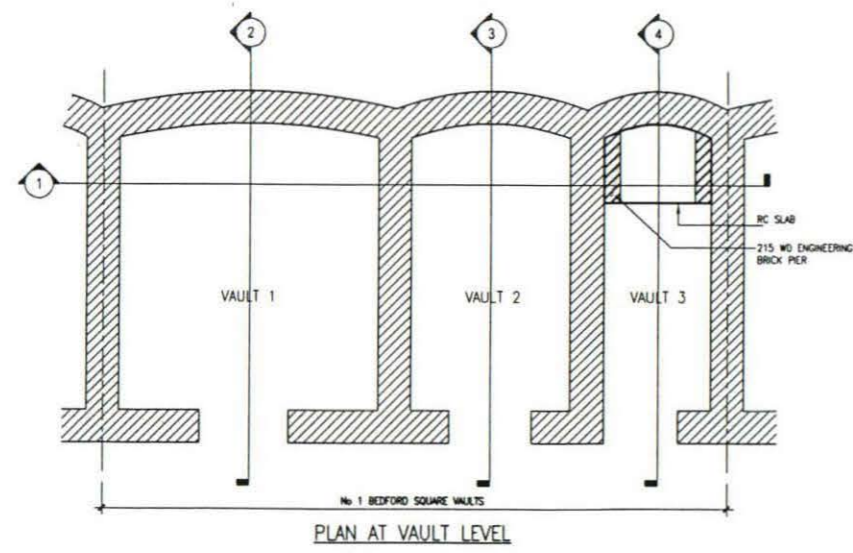
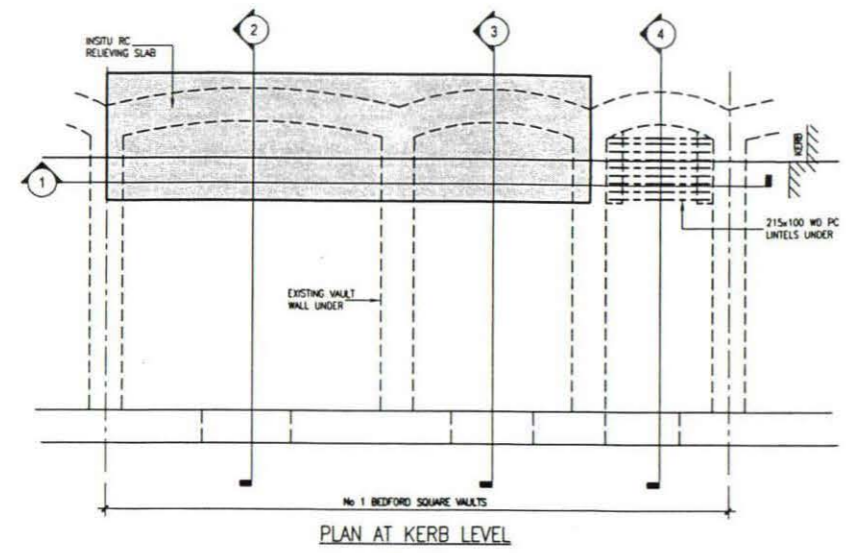

- CONCRETE**
- CONCRETE FOR BLINDING IS TO BE GRADE GEN1.
  - MASS CONCRETE TO BE GRADE FND3.
  - REINFORCED CONCRETE GRADE TO BE RC40.
  - ALL ABOVE IN ACCORDANCE WITH BS 8500
  - CONCRETE WITHIN VAULT 2 TO BE PLACED IN A MINIMUM OF 2 POURS WITH THE UPPER POUR FILLING THE DAMAGED BRICK ARCH RING TO THE UPPER SURFACE OF THE BRICK ARCH.
  - SHUTTERING TO BE BRACED TO THE VAULT SIDE WALLS TO RESIST HYDROSTATIC LOADS.
- REINFORCEMENT**
- ALL REINFORCEMENT TO BE GRADE 460 TYPE 2 UNLESS NOTED OTHERWISE.
  - H DENOTES HIGH YIELD BARS TO B.S. 4449. R DENOTES MILD STEEL BARS TO B.S. 4449.
  - CONCRETE COVER TO BE MAINTAINED BY THE USE OF CONCRETE OR PLASTIC SPACERS, PREWELDED CHAIRS, STOOLS ETC, BROKEN BRICKS OR TILES, ETC MAY NOT BE USED.
- PC LINTELS**
- PC LINTELS TO BE SUPREME CONCRETE R22A OR EQUAL APPROVED
- MASONRY**
- LOADBEARING BLOCKWORK TO HAVE A MINIMUM CHARACTERISTIC COMPRESSIVE STRENGTH OF 10N/mm<sup>2</sup> TO BS 5628 PART 1:1992 UNLESS NOTED OTHERWISE. TO BE TARMAC TRENCH BLOCK OR EQUAL APPROVED.
  - ENGINEERING BRICKS TO HAVE A CHARACTERISTIC COMPRESSIVE STRENGTH OF 50N/MM<sup>2</sup> TO BS 5628 PART 1:1992 UNLESS NOTED OTHERWISE. FURTHER DETAILS TO ARCHITECTS SPECIFICATION.
  - MORTAR IN LOAD BEARING WALLS TO BE DESIGNATION (ii) TO B.S.5628 PART 1:1992
- FOUNDATIONS**
- FOUNDATIONS SHALL BE TAKEN DOWN TO THE SPECIFIED FORMATION IN NATURALLY OCCURRING MATERIAL. THE FORMATION LEVELS SHALL BE INSPECTED BY THE ENGINEER AND THE LOCAL AUTHORITY PRIOR TO CASTING CONCRETE OR LAYING OF hardcore.

**TENDER DRAWING:**  
 THIS DRAWING IS FOR TENDER PURPOSES ONLY AND MUST NOT BE READ AS A CONSTRUCTION ISSUE. IT INDICATES DESIGN INTENT ONLY AND IS SUBJECT TO AMENDMENT DURING FINAL DESIGN DEVELOPMENT.

VAULT 2 WORKS REVISED FOLLOWING E.H. COMMENTS	DP/A	15/12/09	T2
TENDER ISSUE	DP/A	08/12/08	T1
Revision Details	By	Date	Suffix
	Check		

Drawing Status  
**TENDER**

Job Title  
**1 BEDFORD SQUARE VAULTS**

Drawing Title  
**PROPOSED SCHEME FOR VAULT PROTECTION AND SUPPORT**

Scale at A1  
 1:50

Drawn DP	Approved JL
Stage 1 check	Stage 2 check
Originated	Date DEC '09

Scott Wilson  
 6-8 Greenock Place  
 London  
 SW1P 1PL  
 Telephone (020) 7798 5000  
 Fax (020) 7798 5001  
 www.scottwilson.com

Scott Wilson logo

Drawing Number  
**D124263-002**

Rev  
**T2**

FITB COPY  
 2010/597