

DOOR AND SIDELIGHT DETAILS:

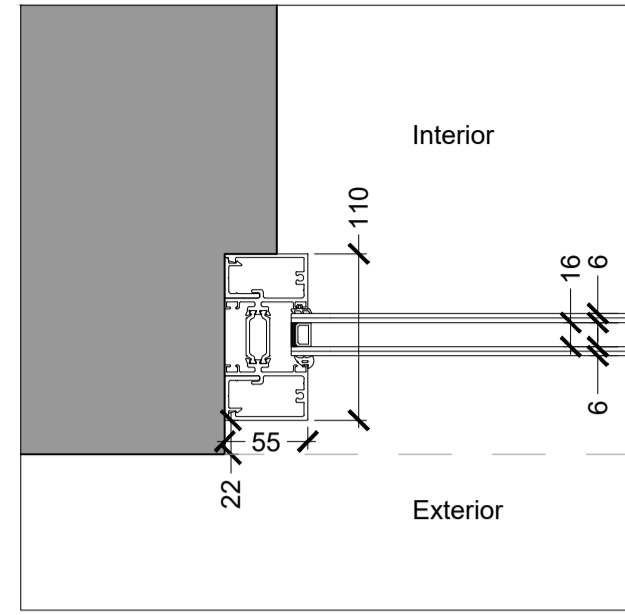

JAMB

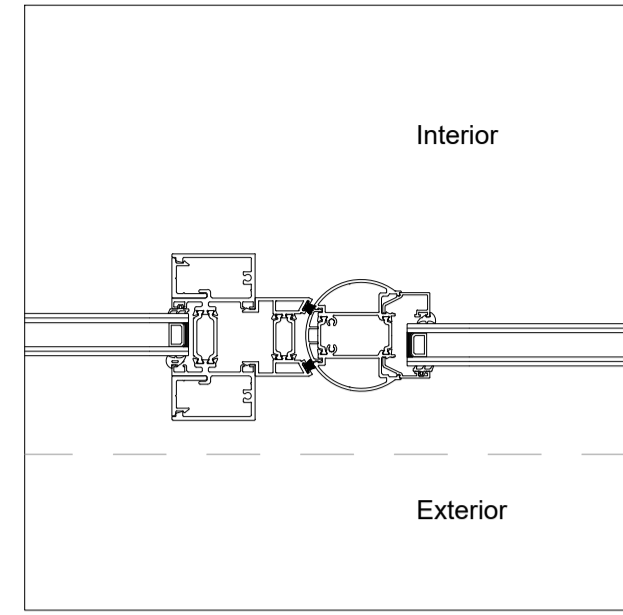

MULLION/DOOR JAMB

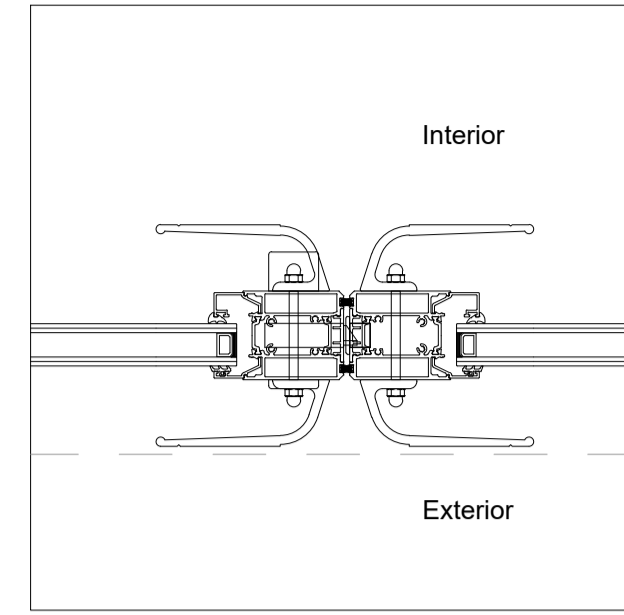

DOOR MEETING EDGE

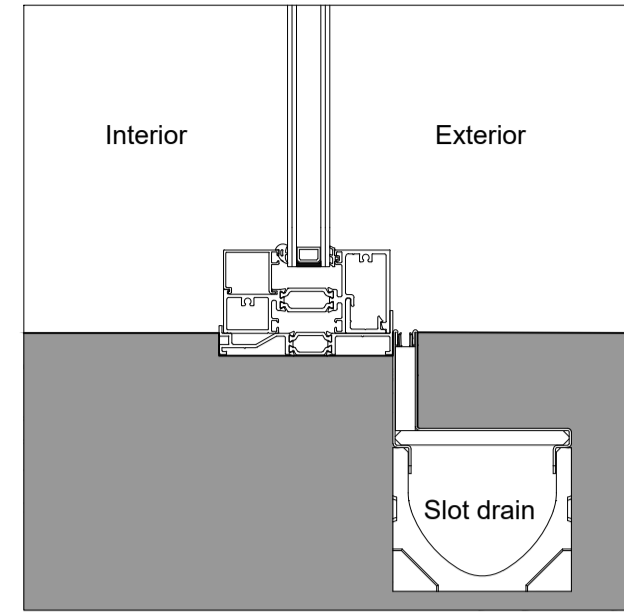

SILL (SIDE LIGHT)

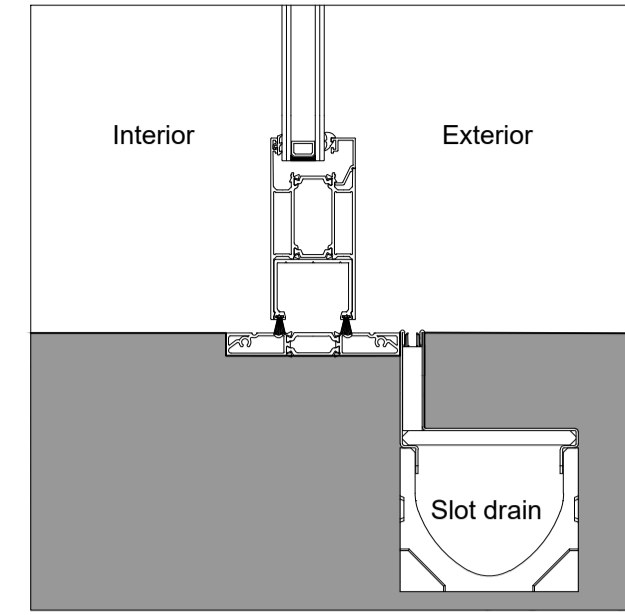

SILL (DOOR)

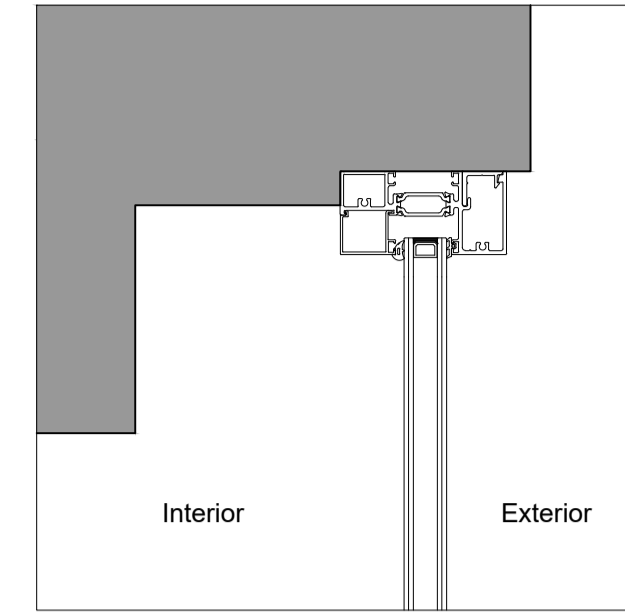

HEAD (SIDE LIGHT)

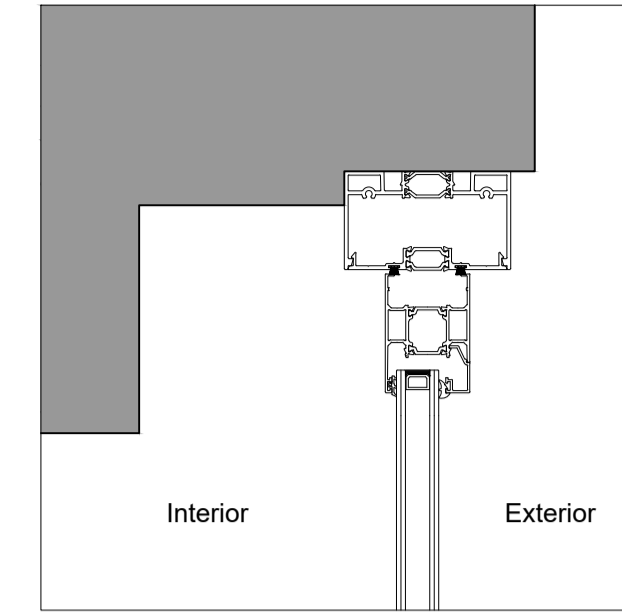

HEAD (DOOR)

SLIDING DOOR DETAILS:

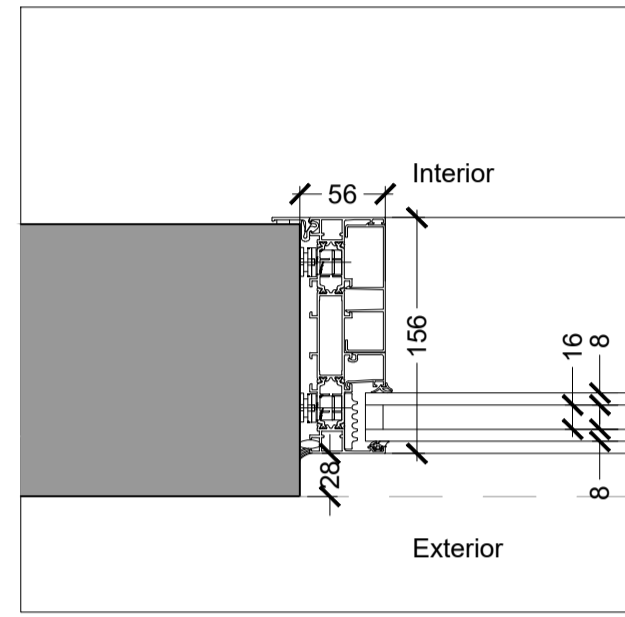

JAMB (FIXED)

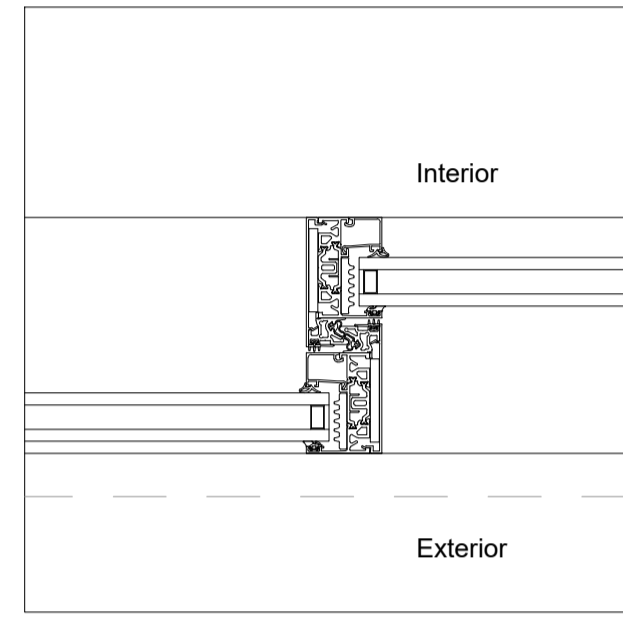

MULLION (FIXED/DOOR)

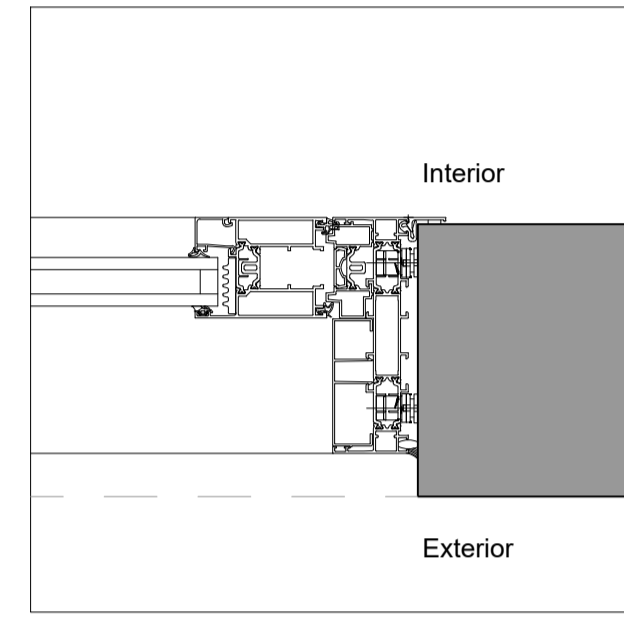

JAMB (DOOR)

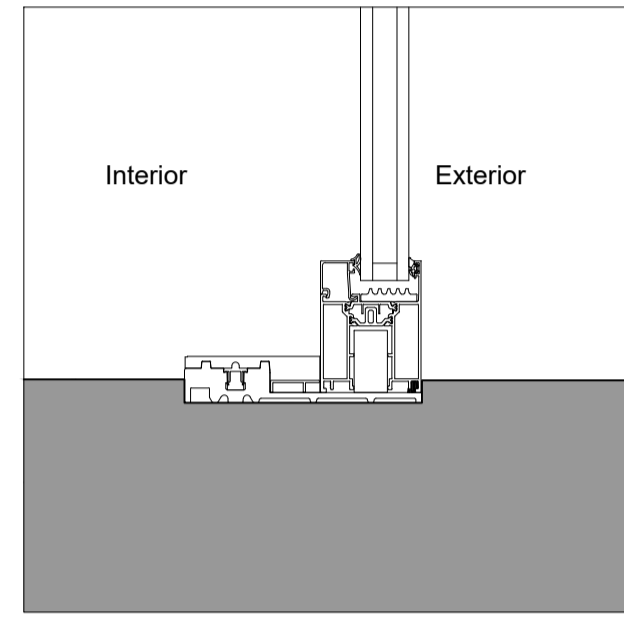

SILL (FIXED)

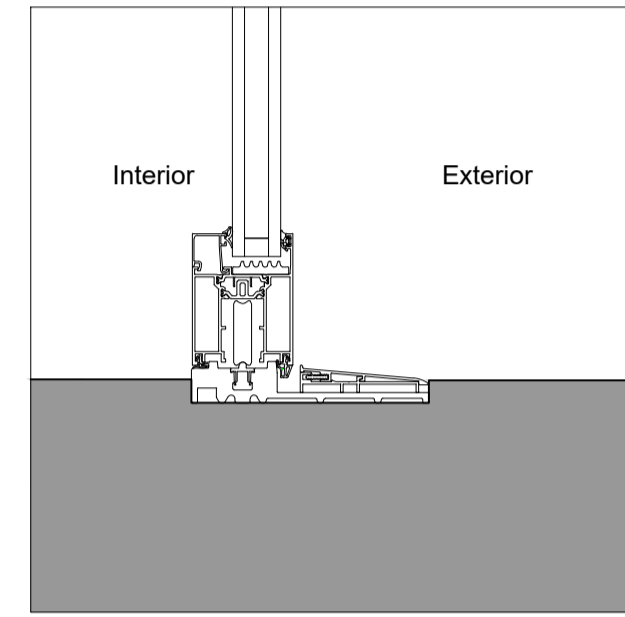

SILL (DOOR)

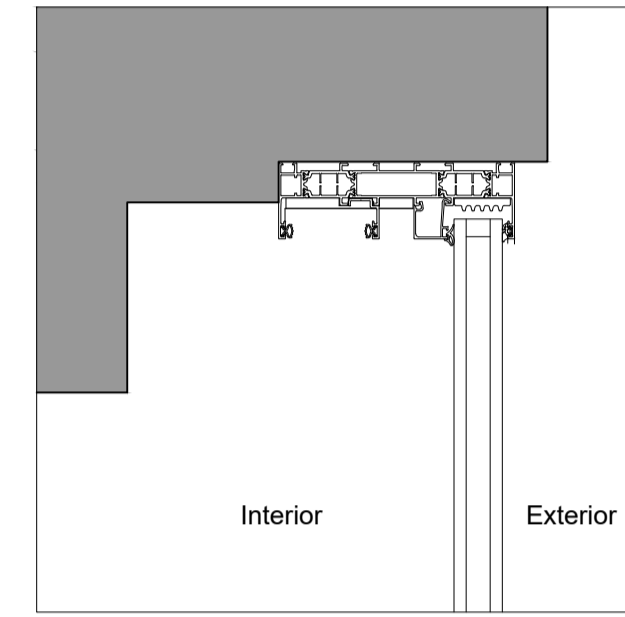

HEAD (FIXED)

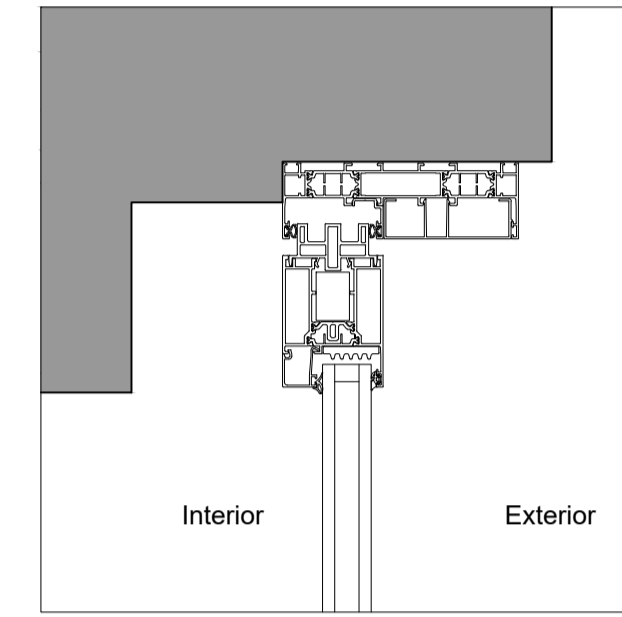

HEAD (DOOR)

TYPICAL WINDOW DETAILS:

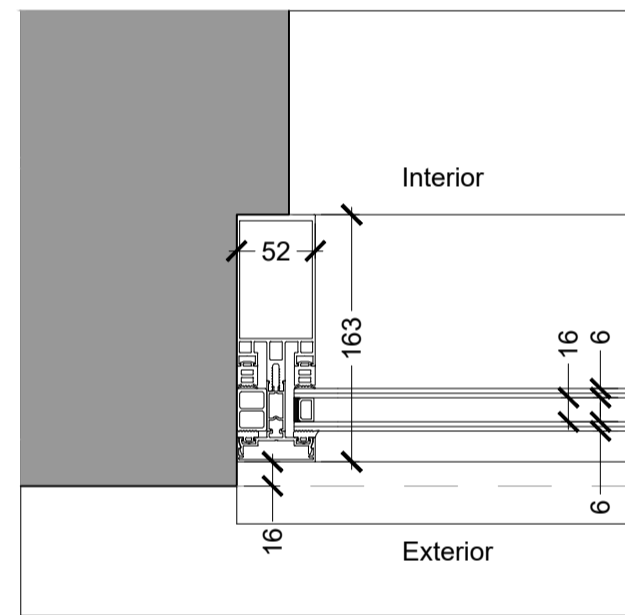

JAMB (FIXED)

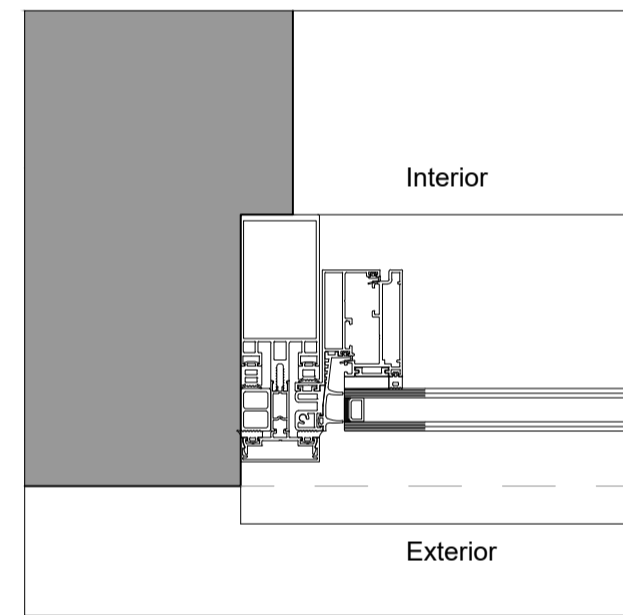

JAMB (OPENABLE)

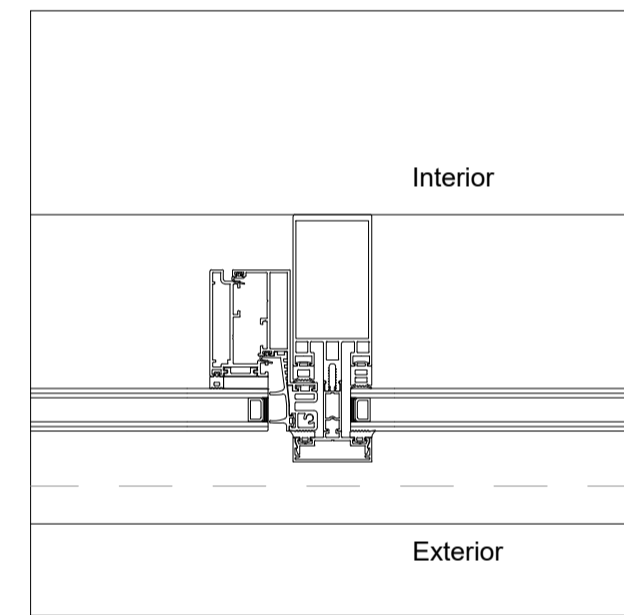

MULLION (OPENABLE/FIXED)

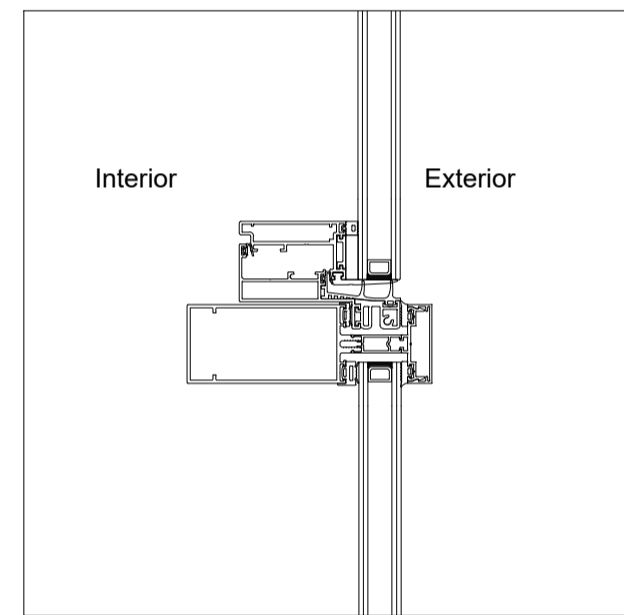

TRANSOM (OPENABLE/FIXED)

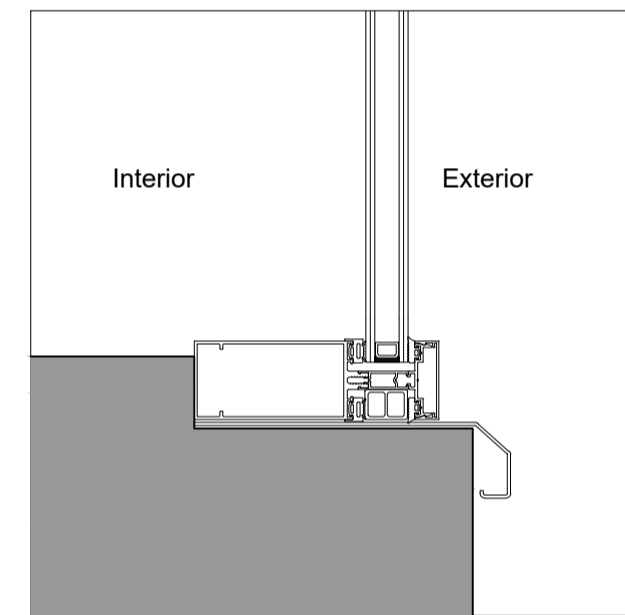

SILL

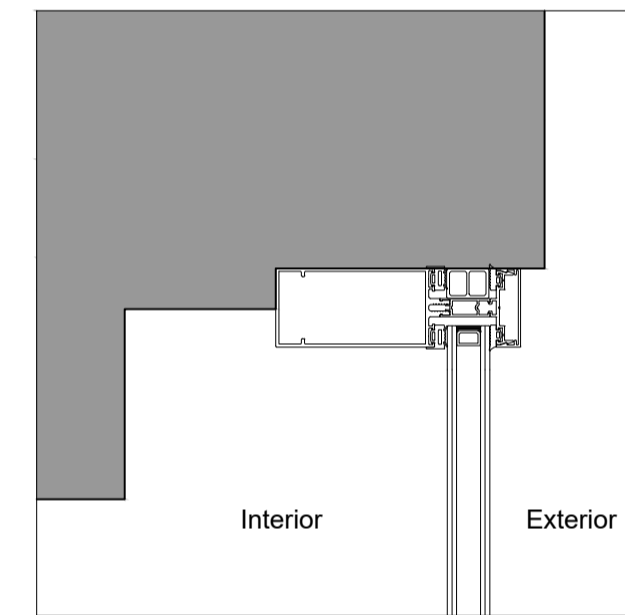

HEAD (FIXED)

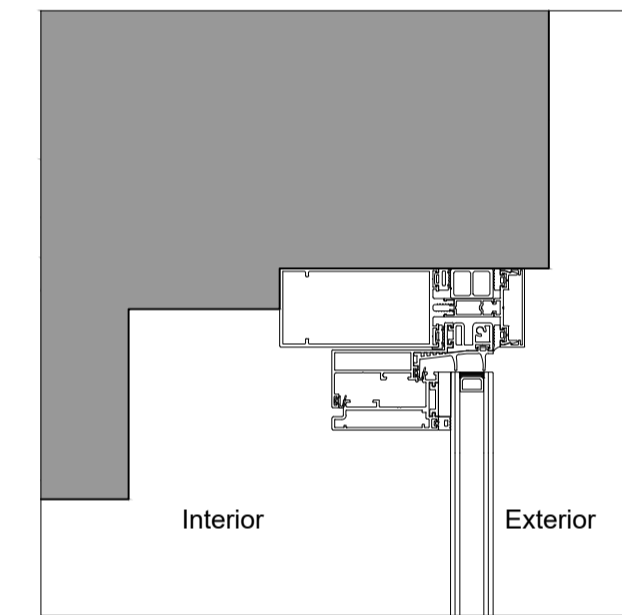

HEAD (OPENABLE)

BIFOLD DOORS:

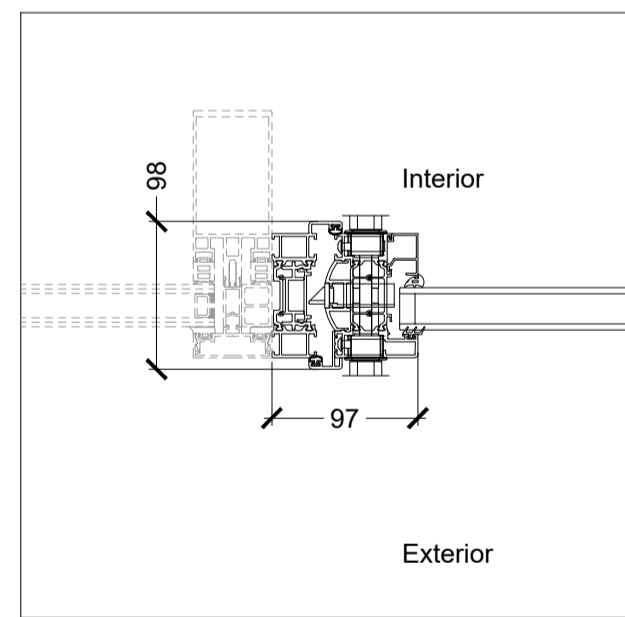

JAMB

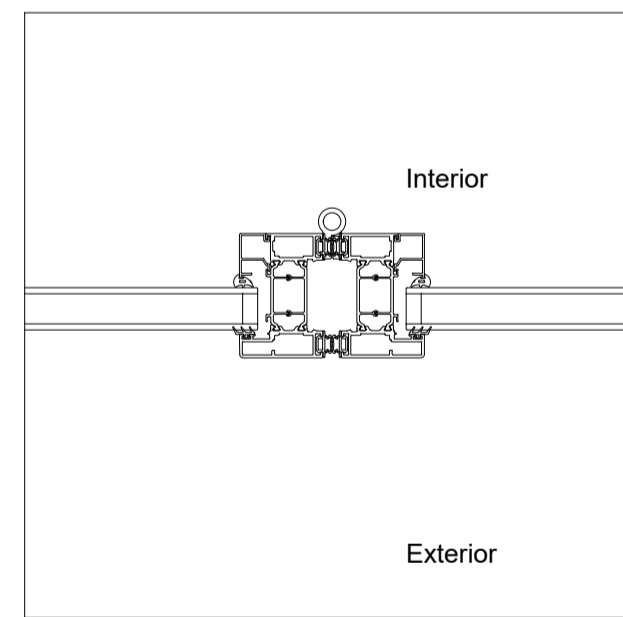

MULLION

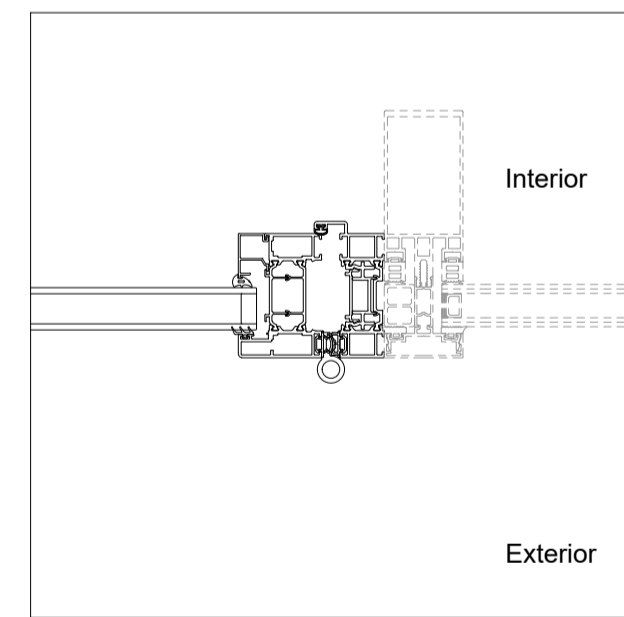

JAMB

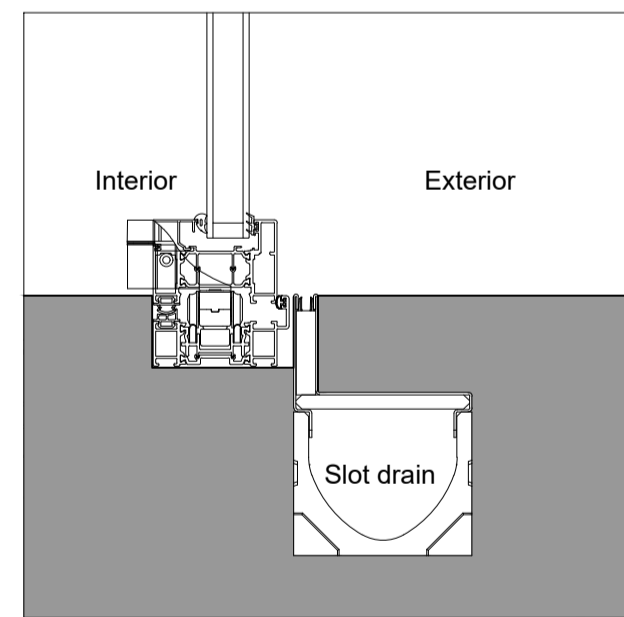

SILL

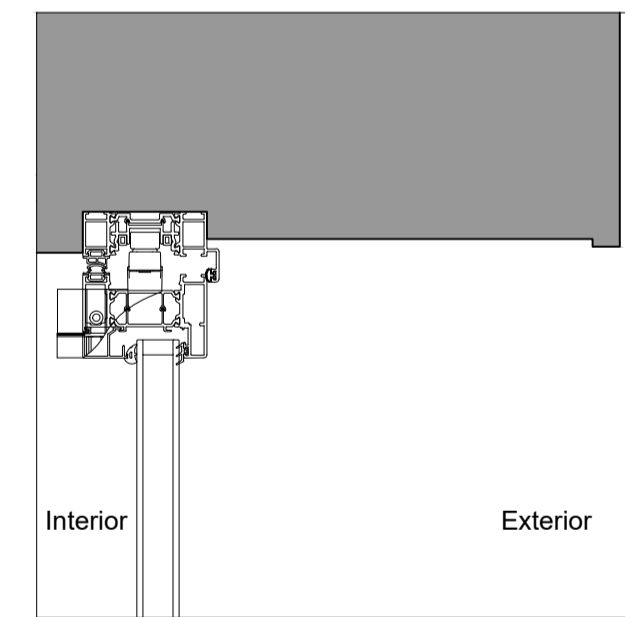

HEAD

EXTERNAL DOOR:

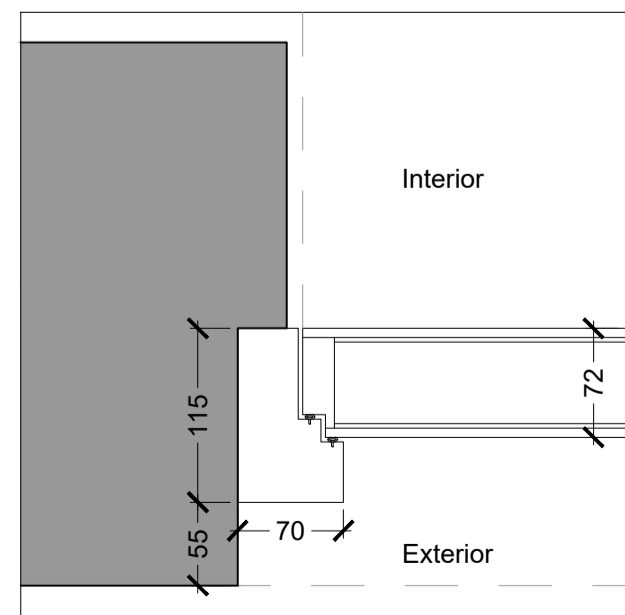

JAMB (DOOR)

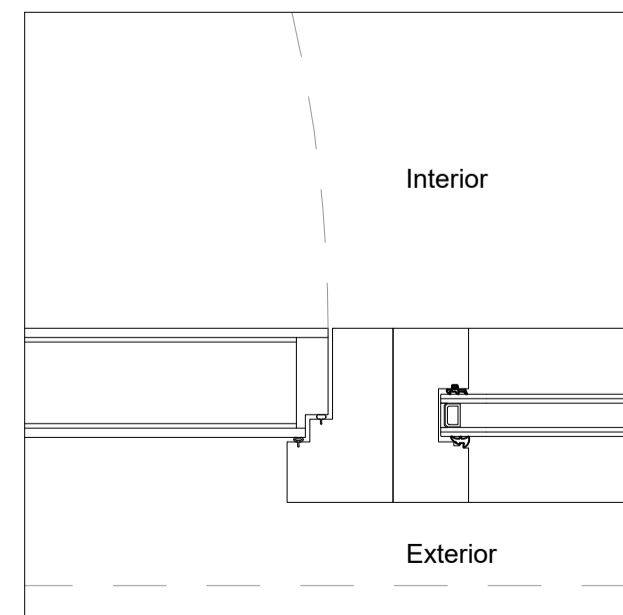

MULLION (DOOR/SIDELIGHT)

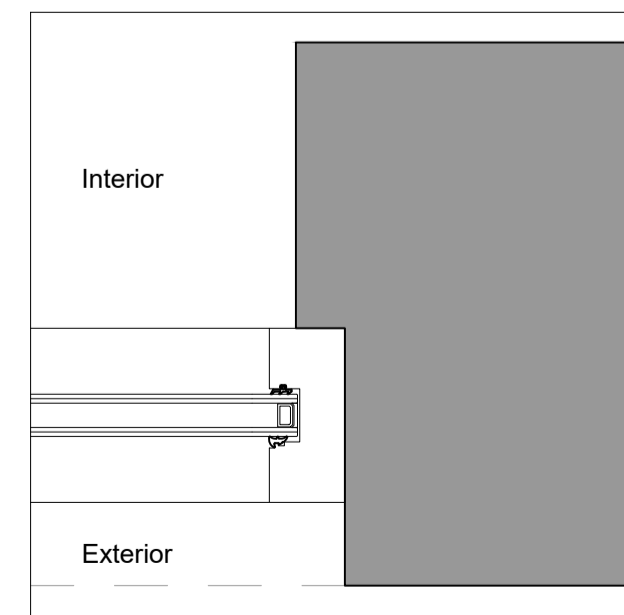

JAMB (SIDELIGHT)

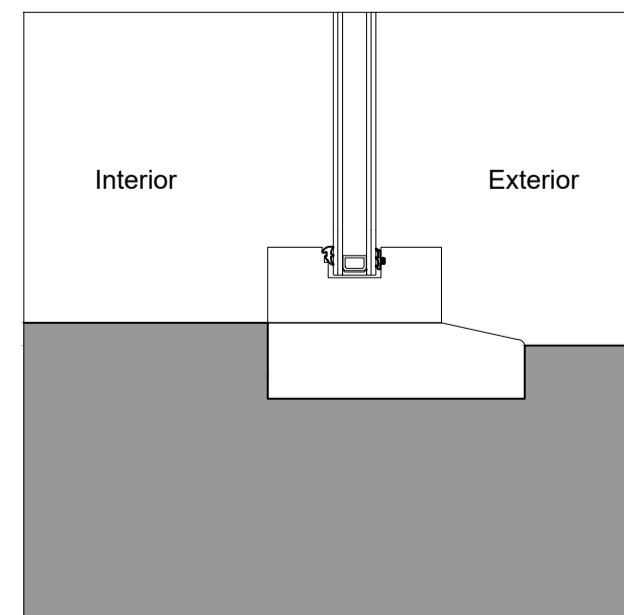

SILL (SIDELIGHT)

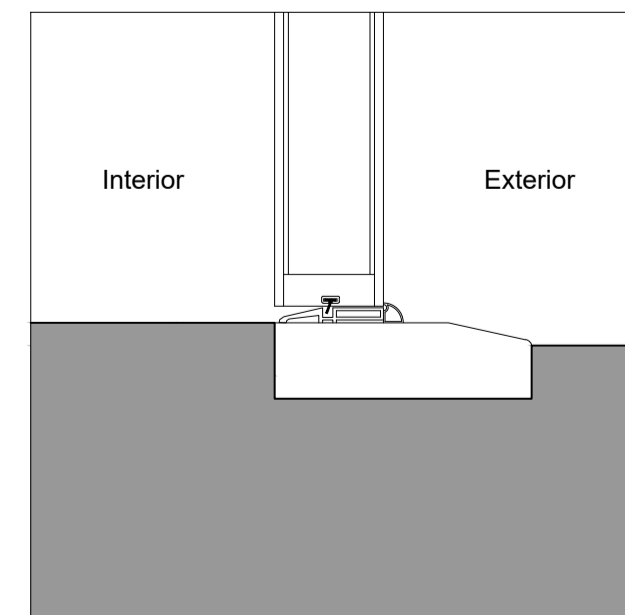

SILL (DOOR)

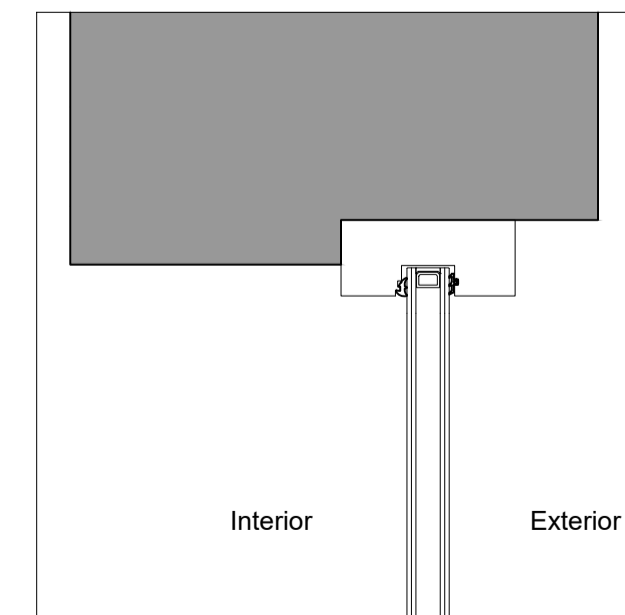

HEAD (SIDELIGHT)

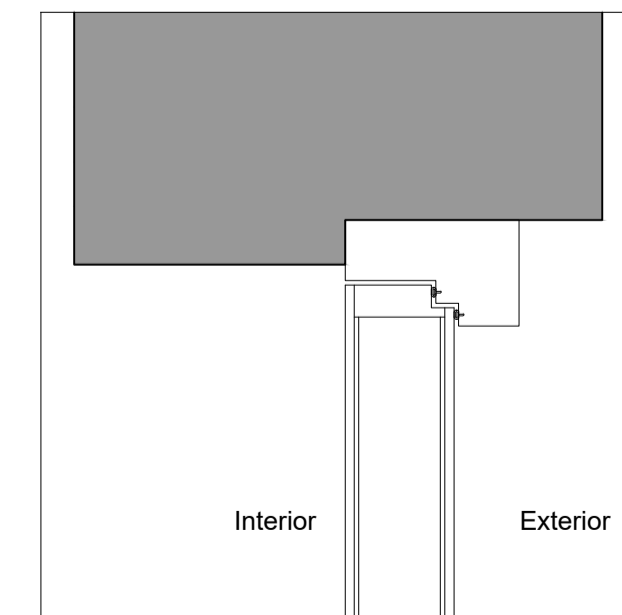

HEAD (DOOR)

DO NOT SCALE FROM THIS DRAWING
ALL DIMENSIONS TO BE CONFIRMED ON SITE BY THE CONTRACTOR PRIOR TO CONSTRUCTION

HEALTH AND SAFETY INFORMATION
REF CONSTRUCTION RISKS

Notes

Windows:
Thermally broken Aluminium slim profile frames.
Ral 7016 Anthracite grey finish.
To achieve U-value of 1.2W/m²K

External Door:
High security door and frame with Double glazed sidelight, full paint finish Ral 7016 Anthracite Grey to match window frames. Ironmongery/access control system TBC

REV	DATE	CHK	AMENDMENTS
00	12/01/18	SR	FIRST ISSUE

UNIT A
Homefield Rd
Haverhill
Suffolk
CB9 8QP
tel: 01440 760090
email: info@radford-group.co.uk
www.radford-group.co.uk



KEY PLAN

CLIENT
Fellows Cottage Ltd
PROJECT
**Fellows Road
London NW3 3JH**
DRAWING
General Door and Glazing Details

FOR INFORMATION		
SCALE 1:5	PAPER A1	DATE Jan 2018
DWG NO FEL101_705	REV 00	

