

RESIDUAL RISKS

1. THERE ARE NO FORESEEN SIGNIFICANT RISKS.

WARNING

INFORMATION ON THIS DRAWING IS PRODUCED USING COLOURS IF DRAWING IS NOT PRINTED IN COLOUR VITAL INFORMATION MAY BE OBSCURED OR MISSING

DUE TO HIGH LEVEL PLANT INSTALLATIONS THE MAJORITY OF WORK SHALL BE CARRIED OUT AT HEIGHT. SAFE WORKING METHODS TO BE OBSERVED DURING INSTALLATION AND MAINTENANCE.

- NOTES:**
- The drawing does not necessarily show all the information needed to interpret the design intent or the construction details.
 - The drawing contains information from more than one source and must be read in conjunction with all relevant specifications.
 - Any apparent drafting errors and differences between other drawings and specifications shall be brought to our attention. Drawings shall be read in conjunction with schematics.
 - The final location, colour and finish of visible items (grilles, extract valves etc.) are to be agreed and approved by the Architect/Client prior to order and installation.
 - Contractor to allow for liaising with the Architect to agree final detail and integration of supply, extract and dummy grilles within joinery, ceiling grid and partitions as required to suit installation.
 - Ventilation & air conditioning / plant controllers shall be surface mount type local to each unit or integrated into the unit or similar.
 - Refer to Architect's drawings for details of ceiling heights and access panels. Generally ceiling void & ceiling construction depths are as follows:
 - Typical Rooms: 100-300mm (3.2m high Ceiling) TBC

- GENERAL NOTES**
- ALL MECHANICAL SERVICES ARE SHOWN INDICATIVE ONLY. THE CONTRACTOR SHALL PROVIDE ALL NECESSARY BENDS, OFFSETS, FITTINGS, ETC. TO SUIT THE INSTALLATION AND BUILDING CONSTRUCTION AND CO-ORDINATE FINAL ROUTES WITH ALL OTHER TRADES/SERVICES.
 - ALL EXISTING SERVICES POSITIONS AND SIZES ARE APPROXIMATE ONLY.
 - THE DRAWING DOES NOT INDICATE THE PRESENCE OF ALL SERVICES EXISTING ON SITE AND IS TO BE READ IN CONJUNCTION WITH THE MECHANICAL SERVICES SPECIFICATION AND DRAWINGS.
 - PIPEWORK TO BE CO-ORDINATED WITH ALL NEW AND EXISTING SERVICES, STRUCTURE, BUILDING CONSTRUCTION ETC.
 - THIS DRAWING IS TO BE READ IN CONJUNCTION WITH THE PROJECT SPECIFICATION AND DRAWINGS. ALL MECHANICAL SERVICES ARE SHOWN INDICATIVE ONLY. THE CONTRACTOR SHALL LIAISE FULLY ON SITE WITH ALL OTHER TRADES TO ENSURE THAT ALL SERVICES CAN BE INSTALLED CORRECTLY. NO SERVICES ARE TO BE INSTALLED PRIOR TO THE PRODUCTION OF FULLY CO-ORDINATED WORKING DRAWINGS.

- STANDARD VENTILATION NOTES**
- THIS DRAWING IS TO BE READ IN CONJUNCTION WITH THE PROJECT SPECIFICATION AND DRAWINGS.
 - PRIOR TO MODIFYING ANY EXISTING SYSTEM THE CONTRACTOR SHALL MEASURE THE EXISTING FLOW RATES & ISSUE RESULTS TO ENGINEER IN A REPORT.
 - ALL DUCTWORK TO BE MANUFACTURED AND INSTALLED TO THE REQUIREMENTS OF HVCA DW 172, SPECIFICATION FOR KITCHEN VENTILATION SYSTEMS.
 - ALL GENERAL VENTILATION DUCTWORK TO BE MANUFACTURED AND INSTALLED TO THE REQUIREMENTS OF HVCA DW 144, LOW PRESSURE, LOW VELOCITY.
 - ALL FRESH AIR INTAKE & EXTRACT DUCTWORK HAVING A HEAT RECOVERY DEVICE FITTED SHALL BE INSULATED & VAPOUR SEALED. SEE ADDITIONAL NOTES.
 - CONDENSE DRAINS SHALL BE PROVIDED TO ALL COOLING COILS & HEAT RECOVERY DEVICES COMPLETE WITH APPROPRIATELY SIZED TRAP. SEE ADDITIONAL NOTES.
 - ACCESS DOORS SHALL BE PROVIDED IN ACCORDANCE WITH THE REQUIREMENTS OF HVCA TR/19, TABLE 2, IN ADDITION ALL ACCESS DOORS SHALL HAVE ONE DIMENSION OF AT LEAST 400mm TO ALLOW ACCESS. ALL ACCESS DOORS SHALL BE FULLY INSULATED, WITH SADDLES ON CIRCULAR DUCTWORK.
 - FLEXIBLE DUCT CONNECTIONS TO DIFFUSERS & GRILLES SHALL NOT EXCEED 1.0m. INSULATED FLEXIBLE DUCT SHALL BE USED ON SUPPLY & HEAT RECOVERY RETURN DUCTWORK.
 - DIFFUSER NECK SIZES ARE SHOWN DIAGRAMMATICALLY ONLY. DIFFUSERS ARE TO BE COMPLETE WITH TRANSFORMATION PLENUM WHERE CONNECTED TO CIRCULAR DUCTWORK. ALL DIFFUSER/GRILLE SIZES AND CONNECTIONS ARE DIAGRAMMATIC ONLY.
 - ALL BENDS SHALL BE MEDIUM RADIUS.
 - THE CONTRACTOR SHALL CO-ORDINATE THE INSTALLATION WITH ALL OTHER SERVICES & THE BUILDING STRUCTURE.
 - ALL VOLUME CONTROL DAMPERS SHALL BE OPPOSED BLADE TYPE & LOCATED ADJACENT TO BRANCH CONNECTIONS.
 - ALL GRILLES & DIFFUSERS SHALL HAVE WELDED MITRES & INDEPENDENT SUPPORTS BACK TO THE MAIN STRUCTURE, THEY SHALL NOT BE SUPPORTED BY THE CEILING GRID.
 - ALL FIRE DAMPERS & FIRE/SMOKE DAMPERS IN PARTITION WALLS SHALL HAVE INDEPENDENT SUPPORTS TO THE MAIN STRUCTURE.
 - INSTALLATION SHALL COMPLY WITH HVCA DW 144.
 - ALL DUCTWORK CONNECTING TO ACOUSTIC LOUVRES SHALL BE LAGGED WITH ACOUSTIC INSULATION.
 - LABELLING OF DUCTWORK SHALL INCLUDE DIRECTION & SERVICE ARROWS & AHU OR EXTRACT FAN SERVING DUCTWORK.
 - ALL VCD'S SHALL HAVE THEIR COMMISSIONED HANDLE POSITIONS CLEARLY MARKED AT COMMISSIONING.

- ADDITIONAL NOTES**
- ONLY FRESH AIR INTAKE AND EXHAUST AIR DUCTWORK SHALL BE THERMALLY INSULATED & VAPOUR SEALED.

- DOMESTIC WATER SERVICES NOTES**
- ALL WATER SERVICES INSTALLATIONS TO COMPLY WITH THE WATER REGULATIONS 1999 AND THE LEGIONELLA CODE/ACOP LB.
 - PRIOR TO MODIFYING ANY EXISTING SYSTEM THE CONTRACTOR SHALL MEASURE THE EXISTING FLOW RATES & ISSUE RESULTS TO ENGINEER IN A REPORT.
 - ALL WORKS SHALL BE IN ACCORDANCE WITH BS806 2012.
 - ALL OUTLETS SHALL BE FITTED C/W ¼ TURN ISOLATING VALVE, CRANE HANDLE FULL FLOW OR EQUIVALENT.
 - ALL HWS R CONNECTIONS SHALL BE MADE NO MORE THAN 2m FROM THE OUTLET.
 - NO BLENDED HWS LEG SHALL EXCEED 1m.
 - ALL PIPEWORK SHALL BE INSTALLED SUCH THAT IT IS SELF VENTING & INSTALLED C/W AUTOMATIC AIR VENTS WITH MANUAL ¼ TURN IV'S. AIR VENTS SHALL HAVE CAPILLARY DISCHARGE PIPEWORK RUN TO CONVENIENT WASTE PIPEWORK C/W TRAPPED FUNDISH.
 - DRAIN COCKS SHALL BE FITTED AFTER MAIN INCOMING IV & MAIN BRANCHES.
 - ALL SURFACE EXPOSED PIPEWORK SHALL BE CHROME. PIPEWORK SHALL BE INSTALLED WITH THE MINIMUM NUMBER OF FITTINGS POSSIBLE.
 - ALL REDUNDANT/CUT BACK PIPELINES SHALL BE REMOVED C/W THE INLINE TEE. NO DEAD LEGS SHALL REMAIN.
 - ALL MCW OUTLETS SHALL BE LABELLED WITH ENGRAVED "TRAFFOLYTE" "DRINKING WATER" LABELS (50mmx15mm).
 - ALL UNBLENDED HOT WATER OUTLETS SHALL BE LABELLED WITH ENGRAVED "TRAFFOLYTE" "WARNING 60°C, HOT WATER" LABELS (50mmx15mm).
 - THE CONTRACTOR SHALL CO-ORDINATE THE INSTALLATION WITH ALL OTHER SERVICES & THE BUILDING STRUCTURE TO ENSURE MAINTENANCE ACCESS.
 - ALL CONCEALED PIPEWORK TO BE INSULATED, CWS & MCW TO BE VAPOUR SEALED.
 - HWS-R PUMP WHERE FITTED, SHALL BE ON THE RETURN.
 - ALL WATER SERVICES PIPEWORK TO BE COPPER TO BS EN 1057-R220.
 - NO PUSH FIT FITTINGS SHALL BE USED.
 - ALL NEW/AFFECTED H&C WATER PIPEWORK SHALL BE CHLORINATED, SAMPLED & TESTED BY CONTRACTORS EMPLOYED SPECIALIST PRIOR TO HANDOVER/BENEFICIAL USE OF ANY AREA. TEST RESULTS SHALL BE ISSUED TO C.A. AT HANDOVER/BENEFICIAL USE OF ANY AREA.
 - WHERE UNINSULATED HWS & CWS PIPEWORK RUN HORIZONTALLY TOGETHER THE CWS PIPE SHALL BE BELOW THE HWS.

- ADDITIONAL NOTES**
- CONTRACTOR TO ALLOW TO STRIP OUT ALL EXISTING REDUNDANT SERVICES FROM EXISTING LOCATIONS BACK TO POINT OF ENTRY INTO THE BUILDING. REFER TO SPECIFICATION.
 - CONTRACTOR TO SITE MEASURE TO CONFIRM SIZES PRIOR TO ORDERING.

LEGEND:

- BCWS BOOSTED COLD WATER SERVICE
- HWS HOT WATER SERVICE
- REFRIGERANT PIPEWORK
- CONDENSATE
- EV NOMINAL DIAMETER EXTRACT VALVES
- SV NOMINAL DIAMETER SUPPLY VALVES
- ATT ATTENUATOR
- EXTRACT DUCT TERMINATES WITH EXTRACT VALVE AT PERIMETER CEILING RECESS
- EXTERNAL LOUVRE - ACTIVE SECTION
- EXTRACT VENTILATION
- SUPPLY VENTILATION
- HOT/COLD WATER SUPPLY TO SANITARY FITTING OR APPLIANCE (C/W SERVING/ CARTRIDGE TYPE FLOW REGULATING VALVES)
- T THERMOSTAT
- C MECHANICAL CONTROLLER

	L/s	mmxmm
	PRESSURE	VELOCITY
	DROP PA/m	m/s
CS	COMMISSIONING SET	
IV	ISOLATING VALVE	
LSV (R)	LOCKSHIELD VALVE (RETURN)	
TRV	THERMOSTATIC RADIATOR VALVE	
TS	TEMPERATURE SENSOR	
T	THERMOSTAT	
TS	TEMPERATURE SENSOR	
F&R	FLOW & RETURN	
H/L	HIGH LEVEL	
L/L	LOW LEVEL	
C/W	COMPLETE WITH	
FC	FLEXIBLE CONNECTION	
FD	FIRE DAMPER	
VCD	VOLUME CONTROL DAMPER	

- FIRE RATED SERVICES NOTES**
- ALL NEW MECHANICAL SERVICES SHALL BE FIRE RATED/FIRE STOPPED IN ACCORDANCE WITH THE RELEVANT ARCHITECTS FIRE STRATEGY PLAN.
 - THE CONTRACTOR SHALL INSTALL FIRE SLEEVES, FIRE COLLARS AND DAMPERS TO MATCH THE ARCHITECTS SPECIFIED FIRE RATING.

- CONDENSATE DRAINAGE NOTES**
- THE DRAWING IDENTIFIES INDICATIVE ROUTES OF THE GRAVITY CONDENSATE DRAINAGE SYSTEMS ONLY. CONTRACTOR TO PROVIDE ALL NECESSARY BENDS, OFFSETS, ETC. TO SUIT THE INSTALLATION AND BUILDING CONSTRUCTION AND CO-ORDINATE FINAL ROUTES WITH ALL OTHER NEW & EXISTING TRADES/SERVICES.
 - DRAINAGE PIPEWORK SHALL BE RUN IN DURAPIPE ABS TUBES AND FITTINGS, SUITABLY GRADED TO FALLS AND ADEQUATELY SUPPORTED THROUGHOUT. REFER TO SPECIFICATION. THE CONTRACTOR SHALL INCLUDE FOR ALL NECESSARY FITTINGS, ADAPTORS, ETC. TO CONNECT TO THE ABOVE GROUND DRAINAGE SYSTEMS

- ROOM CONTROLLER NOTES**
- A CENTRAL CONTROLLER IS TO BE PROVIDED TO SERVE EACH INDIVIDUAL INDOOR UNIT.
 - THE POSITIONS SHOWN FOR THE ROOM CONTROLLER UNITS ARE FOR TENDER PURPOSES ONLY. FINAL POSITIONS ARE TO BE CO-ORDINATED WITH THE SITE CONDITIONS.

- AIR CONDITIONING NOTES**
- ALL REFRIGERANT PIPEWORK ROUTES ARE SHOWN INDICATIVE ONLY. CONTRACTOR TO PROVIDE ALL NECESSARY BENDS, OFFSETS, ETC. TO SUIT THE INSTALLATION AND BUILDING CONSTRUCTION AND CO-ORDINATE FINAL ROUTES WITH ALL OTHER TRADES/SERVICES.
 - ALL REFRIGERANT PIPEWORK SHALL BE INSULATED WITH CLASS 'O' FIRE RESISTANT ARMAFLEX INSULATION, MINIMUM THICKNESS 13MM. ALL INSULATION EXPOSED TO THE ATMOSPHERE MUST BE WATERPROOF AND PAINTED ONLY WITH ARMAFINISH FR PAINT TO PREVENT ULTRAVIOLET DEGRADATION. REFER TO SPECIFICATION.
 - ALL REFRIGERANT PIPEWORK TO BE SUPPORTED NEATLY ON HEAVY DUTY RETURN FLANGE GALVANISED CABLE TRAY. SIZES OF CABLE TRAY INDICATIVE ONLY. POSITIONS OF INDOOR UNITS ARE TO BE CO-ORDINATED WITH THE LIGHTING AND CEILING PLANS, STRUCTURAL STEELWORK AND THE SERVICES.
 - CONDENSATE DISCHARGE PIPE FROM EACH INDOOR UNIT SHALL RUN TO CONNECT TO A FOUL DRAIN IN FULL COMPLIANCE WITH BS6281 & BS2598.
 - CONTRACTOR TO FULLY SUPPORT INDOOR AND EXTERNAL UNITS FULLY IN ACCORDANCE WITH THE MANUFACTURERS RECOMMENDATIONS AND GUIDELINES. THE PROPOSED SUPPORT DETAILS & POSITIONS OF ALL UNITS SHALL BE AGREED WITH THE STRUCTURAL ENGINEER.

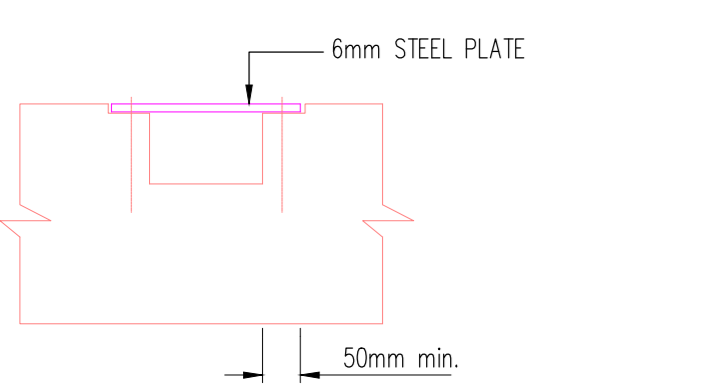

NOTCH REPAIR DETAIL 1
FOR NOTCHES UPTO 25mm DEEP & OVER SERVICES
(SCALE 1:10)

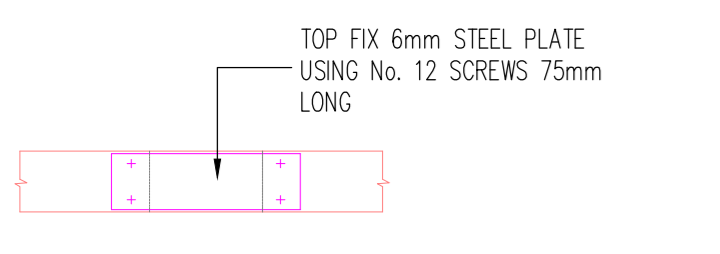

PLAN ON NOTCH REPAIR
(SCALE 1:10)

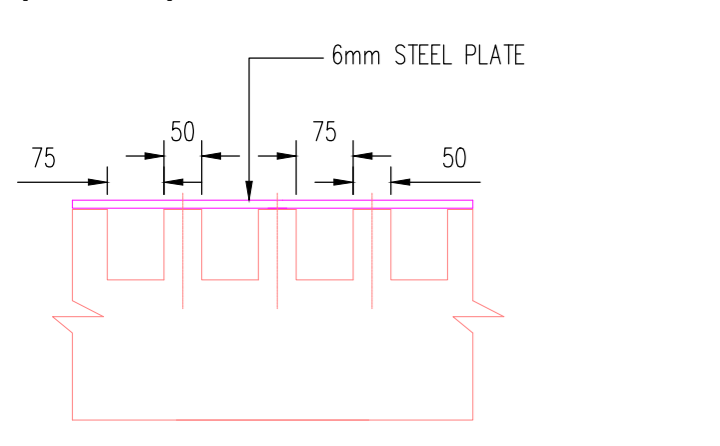

MULTI-NOTCH REPAIR DETAIL 2
FOR NOTCHES UPTO 25mm DEEP & OVER SERVICES
(SCALE 1:10)

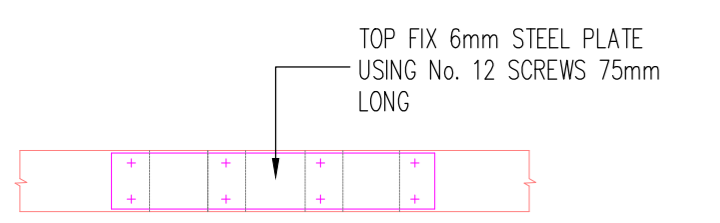

PLAN ON MULTI-NOTCH REPAIR
(SCALE 1:10)

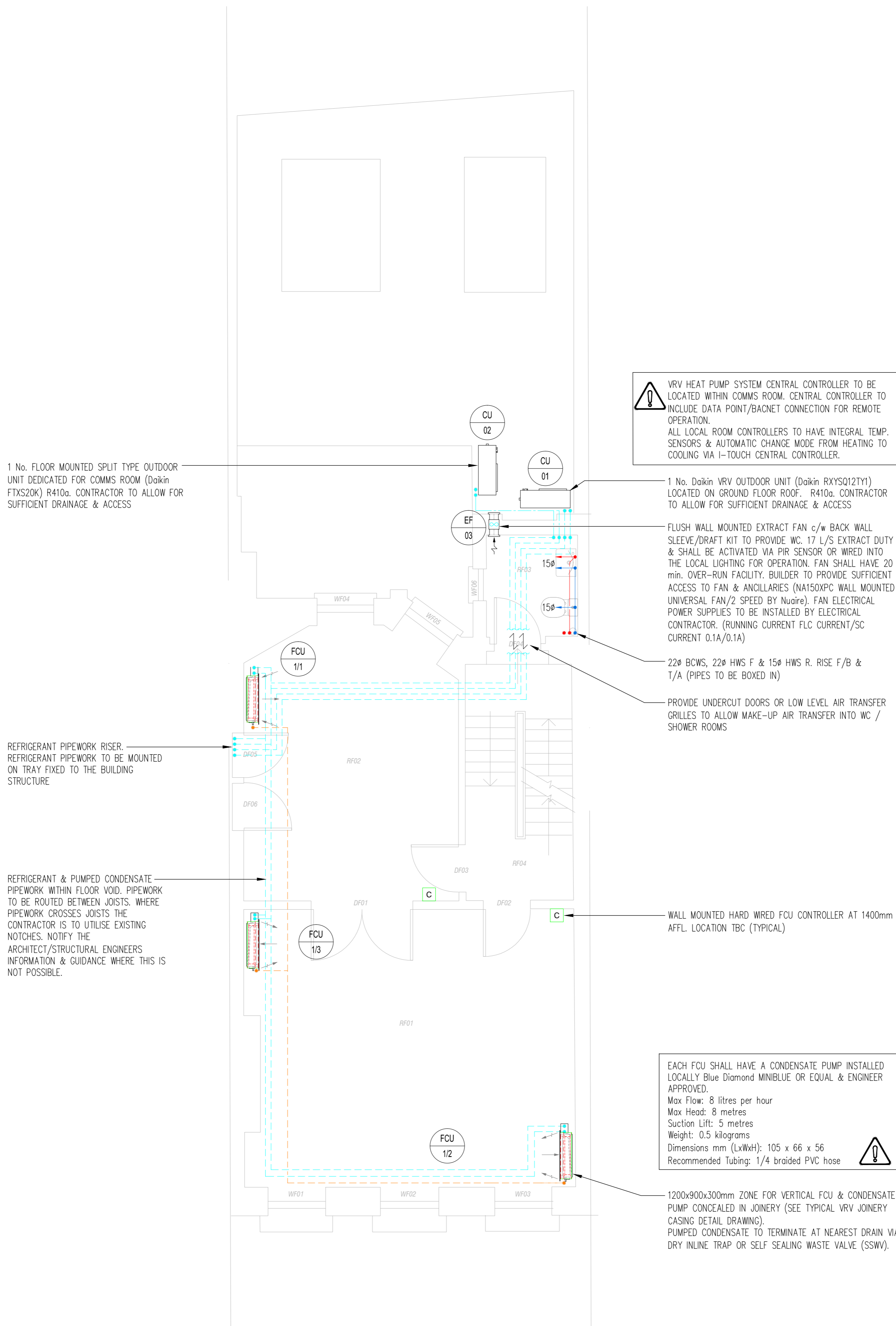

1 No. FLOOR MOUNTED SPLIT TYPE OUTDOOR UNIT DEDICATED FOR COMMS ROOM (Daikin FTXS20K) R410a. CONTRACTOR TO ALLOW FOR SUFFICIENT DRAINAGE & ACCESS

IDENTIFICATION	MAKE	MODEL	TYPE / DATE	Nom. COOLING (kW)	Nom. HEATING (kW)	POWER SUPPLY	RUNNING CURRENT (A) HEATING/COOLING
CU-1	DAIKIN	RXYS012TY1 (R410a)	HEAT PUMP	33.5	33.5	3-PHASE / 32A	13.4
CU-2	DAIKIN	FTXS20K (R410a)	HEAT PUMP	2.0	2.5	1-PHASE / 10A	2.3

IDENTIFICATION	MAKE	MODEL	TYPE	Nom. COOLING (kW)	Nom. HEATING (kW)	AIR VOLUME (L/s) @ LOW-HIGH SPEED SETTING	REFRIGERANT	UNIT SIZE HxWxD (mm)
FCU 1/1	DAIKIN	FXNQ-25A	CONCEALED FLOOR STANDING UNIT	2.8	3.2	107-133	R410a	620x750x200
FCU 1/2	DAIKIN	FXNQ-20A	CONCEALED FLOOR STANDING UNIT	2.2	2.5	107-133	R410a	620x750x200
FCU 1/3	DAIKIN	FXNQ-20A	CONCEALED FLOOR STANDING UNIT	2.2	2.5	107-133	R410a	620x750x200

IDENTIFICATION	MAKE	MODEL	TYPE	STATIC PRESSURE (Pa)	SOUND PRESSURE (dBA)	VOLUME (L/s)
EF-03	NUAIRE	NA100XPC	EXTRACT FAN	0-10	39 @ 3m	17

VRV HEAT PUMP SYSTEM CENTRAL CONTROLLER TO BE LOCATED WITHIN COMMS ROOM. CENTRAL CONTROLLER TO INCLUDE DATA POINT/BACNET CONNECTION FOR REMOTE OPERATION.
ALL LOCAL ROOM CONTROLLERS TO HAVE INTEGRAL TEMP. SENSORS & AUTOMATIC CHANGE MODE FROM HEATING TO COOLING VIA I-TOUCH CENTRAL CONTROLLER.

1 No. Daikin VRV OUTDOOR UNIT (Daikin RXYS012TY1) LOCATED ON GROUND FLOOR ROOF. R410a. CONTRACTOR TO ALLOW FOR SUFFICIENT DRAINAGE & ACCESS

FLUSH WALL MOUNTED EXTRACT FAN c/w BACK WALL SLEEVE/DRAFT KIT TO PROVIDE WC. 17 L/S EXTRACT DUTY & SHALL BE ACTIVATED VIA PIR SENSOR OR WIRED INTO THE LOCAL LIGHTING FOR OPERATION. FAN SHALL HAVE 20 min. OVER-RUN FACILITY. BUILDER TO PROVIDE SUFFICIENT ACCESS TO FAN & ANCLARIES (NA150XPC WALL MOUNTED UNIVERSAL FAN/2 SPEED BY Nuaire). FAN ELECTRICAL POWER SUPPLIES TO BE INSTALLED BY ELECTRICAL CONTRACTOR. (RUNNING CURRENT FLC CURRENT/SC CURRENT 0.1A/0.1A)

22ø BCWS, 22ø HWS F & 15ø HWS R. RISE F/B & T/A (PIPES TO BE BOXED IN)

PROVIDE UNDERCUT DOORS OR LOW LEVEL AIR TRANSFER GRILLES TO ALLOW MAKE-UP AIR TRANSFER INTO WC / SHOWER ROOMS

WALL MOUNTED HARD WIRED FCU CONTROLLER AT 1400mm AFFL. LOCATION TBC (TYPICAL)

EACH FCU SHALL HAVE A CONDENSATE PUMP INSTALLED LOCALLY Blue Diamond MINIBLUE OR EQUAL & ENGINEER APPROVED.
Max Flow: 8 litres per hour
Max Head: 8 metres
Suction Lift: 5 metres
Weight: 0.5 kilograms
Dimensions mm (LxWxH): 105 x 66 x 56
Recommended Tubing: 1/4 braided PVC hose

1200x900x300mm ZONE FOR VERTICAL FCU & CONDENSATE PUMP CONCEALED IN JOINERY (SEE TYPICAL VRV JOINERY CASING DETAIL DRAWING).
PUMPED CONDENSATE TO TERMINATE AT NEAREST DRAIN VIA DRY INLINE TRAP OR SELF SEALING WASTE VALVE (SSWV).

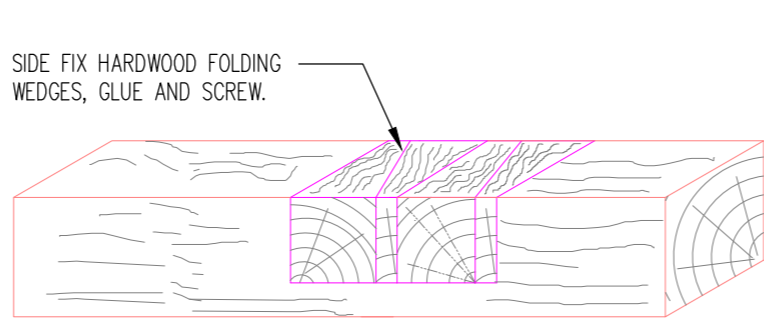

NOTCH REPAIR DETAIL 1
FOR LONG NOTCH APPLICATIONS
FOR NOTCHES GREATER THAN 25mm DEEP
(SCALE 1:20)

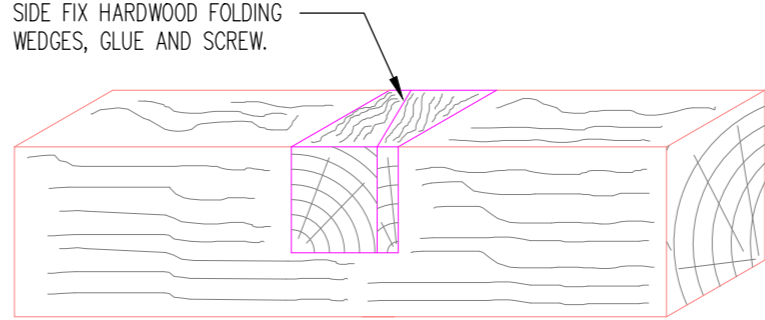

NOTCH REPAIR DETAIL 2
FOR NOTCHES GREATER THAN 25mm DEEP
(SCALE 1:20)

XREF HISTORY

Architects information			
Company	Filename	Drawing No.	Revision
-	EXISTING & PROPOSED FIRST FLOOR PLAN	-	DRAFT

Rev	Dwn	Date	Description
P2	SEEM	03.11.17	PRELIMINARY ISSUE
P1	PDJ	04.09.17	PRELIMINARY ISSUE

PURPOSE OF ISSUE

PRELIMINARY

CLIENT
THE BEDFORD ESTATES

SCHEME
6 BAYLEY STREET
LONDON

TITLE
MECHANICAL SERVICES
FIRST FLOOR

© THIS DESIGN IS THE PROPERTY OF ITD CONSULTANTS LTD AND SHALL NOT BE REPRODUCED OR COPIED IN ANY WAY OR CONVEYED TO A THIRD PARTY WITHOUT THE OWNERS WRITTEN PERMISSION.

itd CONSULTANTS LOW CARBON CONSULTANTS

ITD CONSULTANTS LTD (ENGINEERING SERVICES)
Tel: 023 9243 5050
www.itdconsultants.co.uk
e-mail: eng@itdconsultants.co.uk

SCALE 1:50 @ A1	DATE SEP. 2017
DRAWN BY PDJ	CHECKED BY ITD
DRAWING NO. 17/2470/M02	REVISION P2