

1 REAR DOOR DL02
SCALE 1:10 EXTERNAL ELEVATION
PL-53

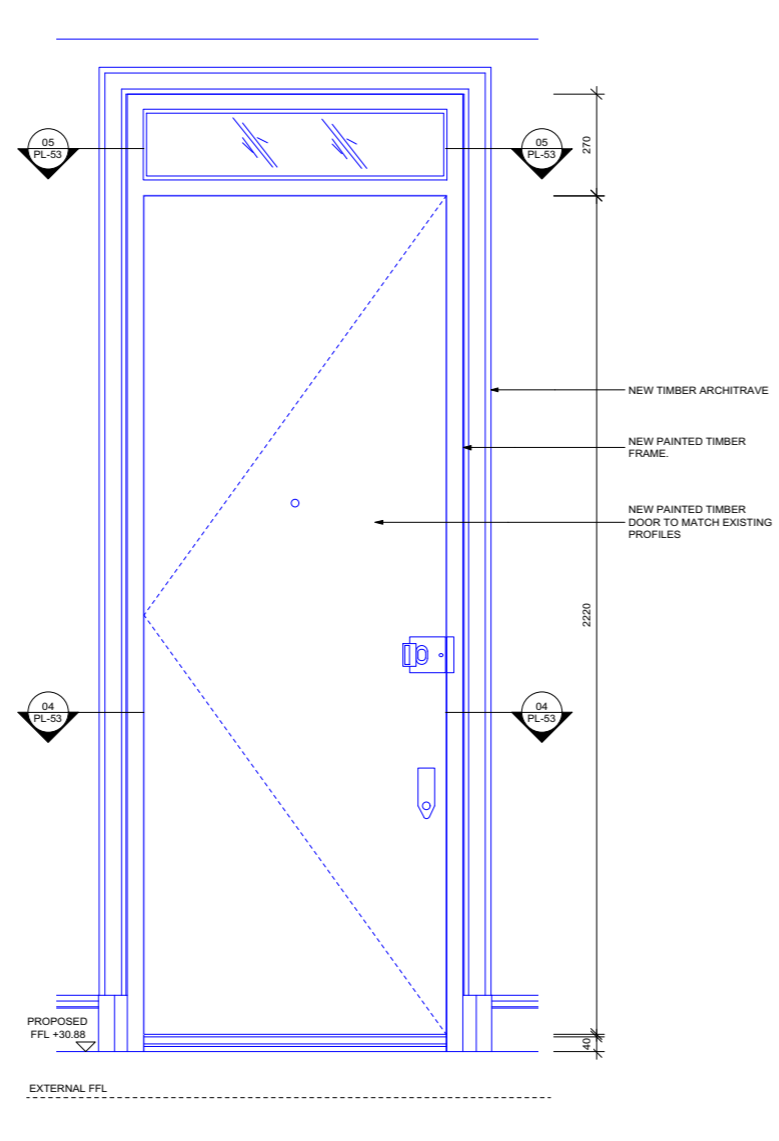

02 REAR DOOR DL02
SCALE 1:10 INTERNAL ELEVATION
PL-53

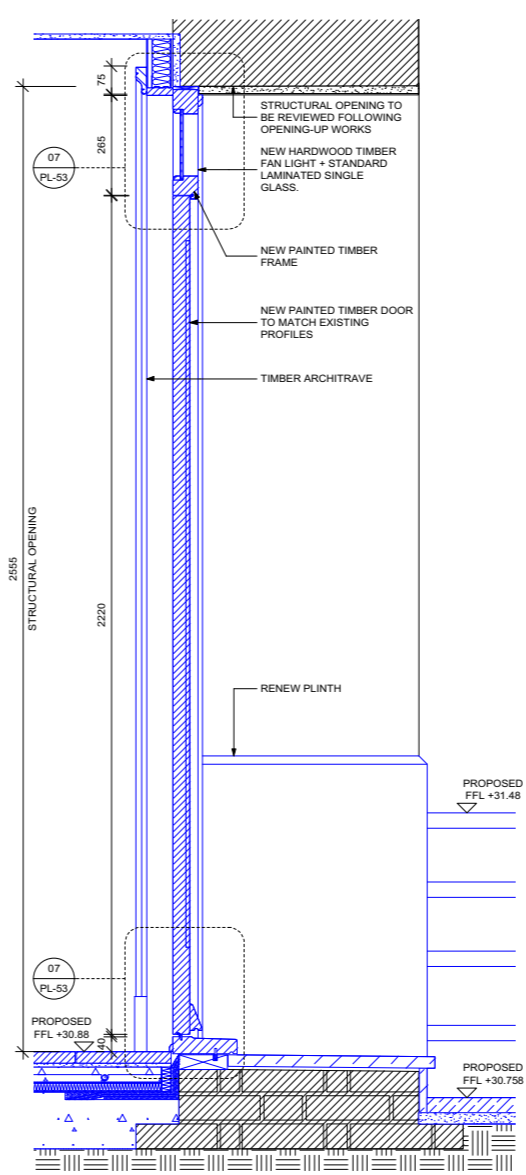

03 REAR DOOR DL02
SCALE 1:10 SECTION
PL-53

GENERAL NOTES

1. THIS DRAWING IS TO BE READ IN CONJUNCTION WITH DOOR SCHEDULE AND NBS SPECIFICATIONS.
2. REPLACEMENT DOOR LEAF TO MATCH PROFILES OF EXISTING DOOR.
3. FRAME SIZES TO BE COORDINATED WITH ON-SITE DIMENSIONS OF STRUCTURAL OPENINGS
4. IRONMONGERY AS PER IRONMONGERY SCHEDULE.



08 EXISTING EXTERNAL DOOR
PL-53

COPYRIGHT 2017 STANHOPE GATE ARCHITECTURE

THESE DRAWINGS ARE FOR AESTHETIC DESIGN INFORMATION PURPOSES ONLY & DO NOT CONTAIN ANY INFORMATION FOR CONSTRUCTION OR COMPLIANCE TO BUILDING REGULATIONS.

DRAWINGS MAY BE SCALED FOR THE PURPOSES OF PLANNING ONLY. ALL DIMENSIONS TO BE CHECKED ON SITE.

KEY:

S - INTERNAL WINDOW SILL HEIGHT
H - INTERNAL WINDOW SILL TO HEAD HEIGHT
FFL - TOP OF FINISHES
SSL - TOP OF STRUCTURAL SLAB LEVEL

	EXISTING BLOCKWORK
	EXISTING BRICKWORK
	EXISTING STONE
	EXISTING WALL
	NEW BLOCKWORK
	NEW BRICKWORK
	NEW STONE

PLANNING ISSUE

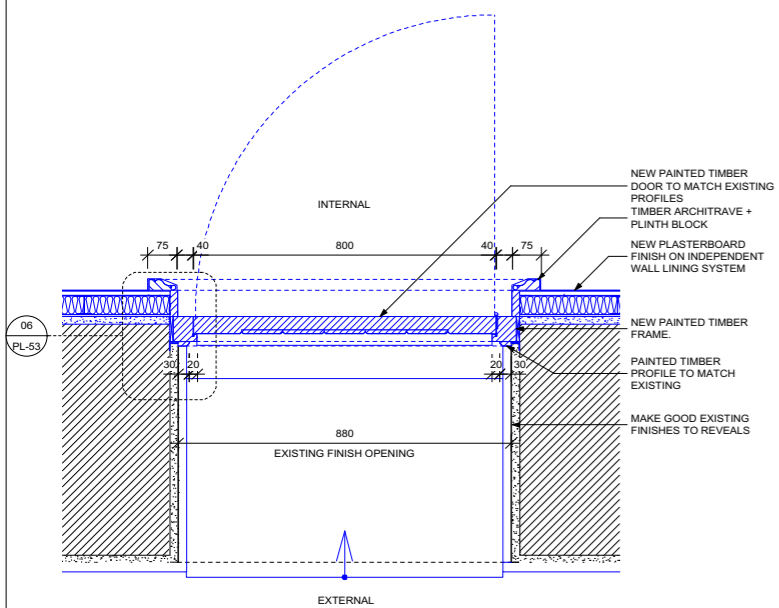

04 REAR DOOR DL02
SCALE 1:10 PLAN
PL-53

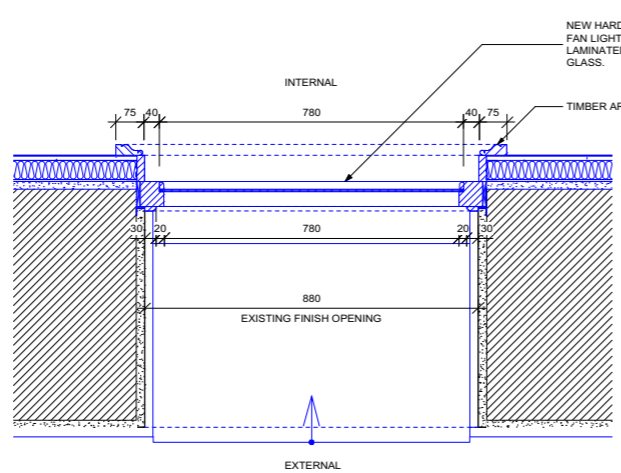

05 REAR DOOR DL02
SCALE 1:10 PLAN
PL-53

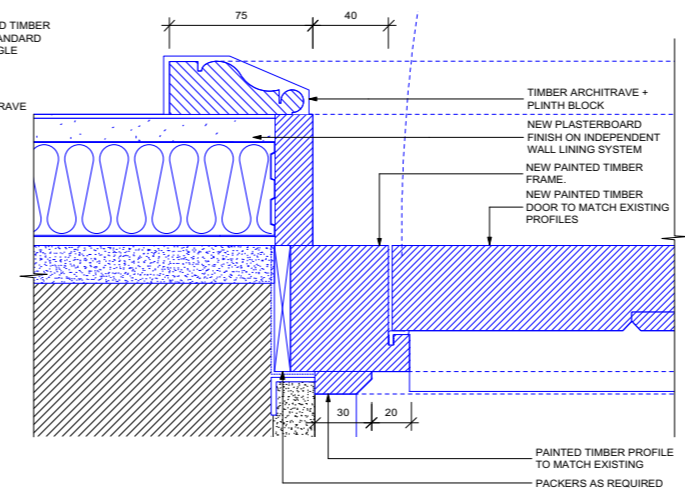

06 REAR DOOR DL02
SCALE 1:2 JAMB DETAIL
PL-53

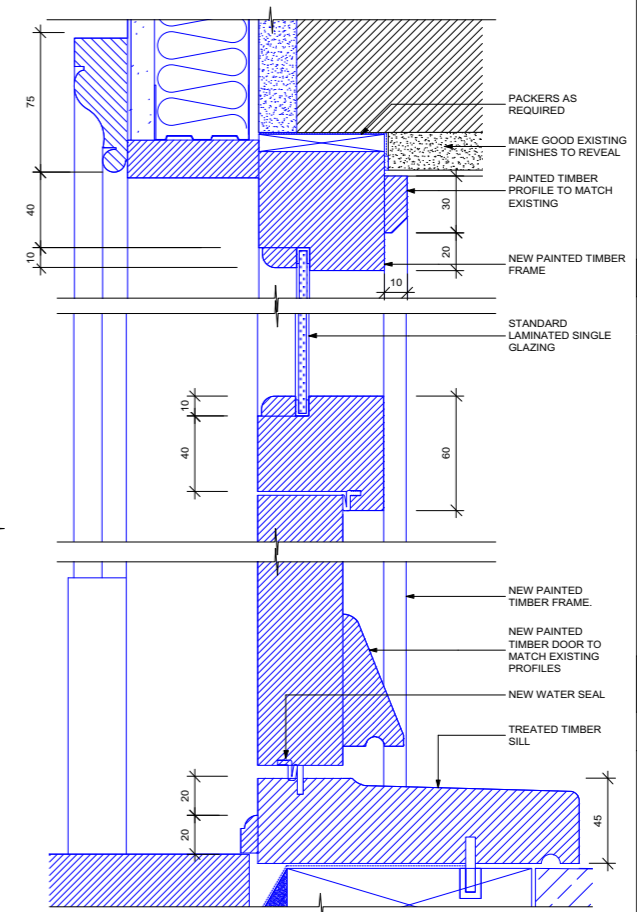

07 REAR DOOR DL02
SCALE 1:2 HEAD & THRESHOLD DETAIL
PL-53

REV.	DATE	DESCRIPTION
------	------	-------------

36-37 CHESTER TERRACE
LONDON

EXTERNAL DOOR DETAILS -
DL02

DRNG No PL-53	SCALE 1:10/12 @ A1 1:20/14 @ A3	DATE NOV-17
------------------	---------------------------------------	----------------



5 ST JAMES'S SQUARE
LONDON SW1Y 4JU
T 020 7451 0955 mail@stanhopegate.co.uk
www.stanhopegatearchitecture.com

