



METHOD STATEMENT

Sika® SolarMount-1 - Exposition South

FEBRUARY 17, 2015 / VERSION 08 / SIKA SERVICES AG

TEMPLATE FOR LOCAL ADAPTION

INHALTSVERZEICHNIS

| | | |
|---|--|---|
| 1 | Notes on the Sika SolarMount-1 system (Exposition South) for PV solar arrays | 3 |
| 2 | Setting up on site | 3 |
| 3 | Required Tools for mounting Sika SolarMount-1 to Sika roofing membranes | 4 |
| 4 | Installation of Sika SolarMount-1, step by step | 4 |

1 NOTES ON THE Sika SolarMount-1 SYSTEM (EXPOSITION SOUTH) FOR PV SOLAR ARRAYS

Sika SolarMount-1 is suitable for the mounting solar systems on flat roofs with a roof pitch of up to 5° (10° with additional measures), covered with single-ply roof waterproofing membranes from Sika. The system can be placed without penetration of the roof waterproofing membrane. Integrated cable channels, stackable components and the requirement for only a few tools, considerably reduces the working time on the roof. Sika SolarMount-1 can be used with or without ballasting, such as paving stones (e.g. 200 x 100 x 80 mm), according to the roof and PV system design. This system is used for fastening the frames for PV modules that are 973 - 1013 mm wide with a frame height of 35 - 50 mm, and a weight of max. 25 kg. The racks provide an elevation of 15° from the roof plane. The Sika SolarMount-1 system consists of modular mounted units. There are variants for 1 - 4 modules. The distance between the mounts is determined from the static requirements arising from the relevant wind and snow loading zones. Dependent on these climatic conditions, not all of the available systems can be used.

The mounts are attached to the Sika roof waterproofing membrane by welding the membrane fixing flaps on the Sika SolarClick FPO or PVC systems. This ensures total compatibility between the membrane and the fixing flaps, together with their suitability for easy and secure welding. The roof's thermal insulation must be adequately designed and capable of absorbing the additional localized loadings imposed under the mounts on long term. This is also necessary to avoid effects such as ponding water, if any subsidence or permanent deformation was to occur. The complete structural design and build-up, together with optimized lay-out and ballasting plans are all provided by Centroplan GmbH. The cabling plans are designed by the electric planner and are made available by the PV installation customer.

2 SETTING UP ON SITE

Please be especially careful with transport and interim storage of the PV modules on site and ensure a safe working environment. The Sika SolarMount-1 system is transported and delivered on heavy pallets. A crane will be required on site if the pallets have to be lifted onto the roof.

Caution:

Only place these pallets on sufficiently stable roofs that are capable of accommodating the load and ensure that all roof surfaces are clean when the Sika SolarMount-1 system is installed. The maximum age of an existing Sika roof membrane is 3 years, but depending on its condition.

(Alternatively the PV racks can be pre-assembled on installation tables up to working step 15)

The information contained herein and any other advice are given in good faith based on Sika's current knowledge and experience of the products when properly stored, handled and applied under normal conditions in accordance with Sika's recommendations. The information only applies to the application(s) and product(s) expressly referred to herein. In case of changes in the parameters of the application, such as changes in substrates etc., or in case of a different application, consult Sika's Technical Service prior to using Sika products. The information contained herein does not relieve the user of the products from testing them for the intended application and purpose. All orders are accepted subject to our current terms of sale and delivery. Users must always refer to the most recent issue of the local Product Data Sheet for the product concerned, copies of which will be supplied on request.

3 REQUIRED TOOLS FOR MOUNTING Sika SolarMount-1 TO SIKA ROOFING MEMBRANES

- Cordless screwdriver
- Socket spanner 17 mm
- Ratchet
- Torque wrench
- Measuring tape
- Pencil
- Handheld hot-air welder
- Rubber pressure roller
- Torx-Bits T25, T40

4 INSTALLATION OF Sika SolarMount-1, STEP BY STEP

1 Alignment of assembly rails

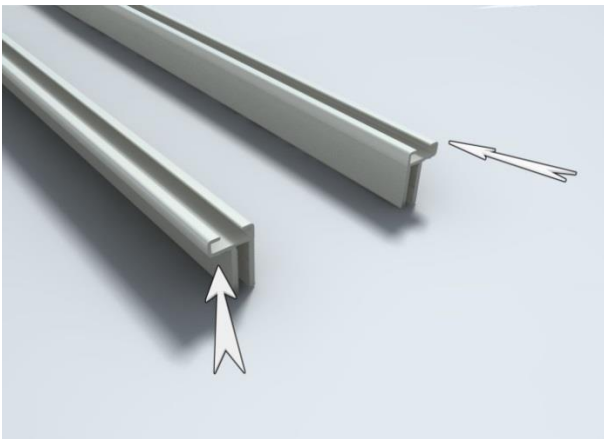

Place two assembly rails together so the ridges (see arrows) are facing outwards and the hammer-head screw location groove faces above.

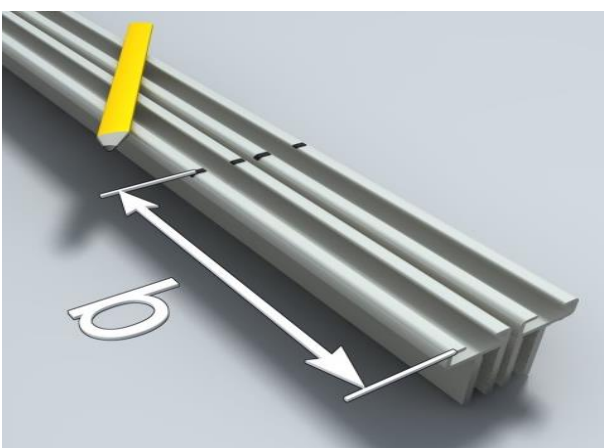

Place the marks for the screws on both assembly rails using a pencil.
The respective distances are shown in table 1 or in the designer's drawing.

Example:

For a 4.4 arrangement, the first mark is placed at a distance (b) of 0.15 m from the start of the assembly rails followed by three further marks at equal distance (a) of 1.90 m producing a distance to the other end of the mounting rail of 0.15 m.

2 Determination of Dimensions a), b), c) und d)

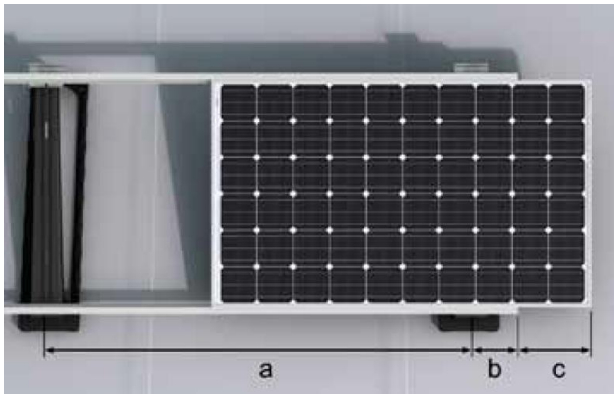

Note: Rail cantilever left (b_L) and right (b_R) are different

- (b_L) on the left side, looking from the lower panel side
- (b_R) on the right side, looking from the higher panel side

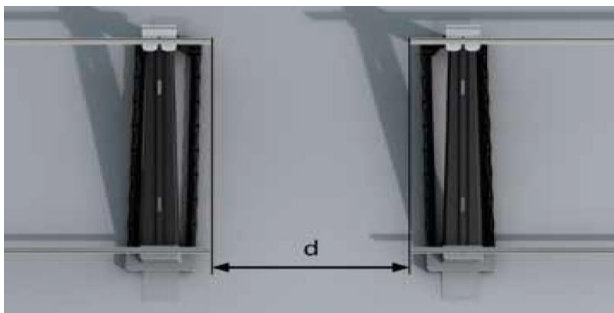

The distance between two systems must be considered due to the different systems Sika SolrMount-1 and the system-dependent overhang of the modules above the rails. The distance under discussion here is the distance d) between the respective rail ends.

The individual distances for the several Sika SolarMount-1 systems may be taken from the tables 1 and 2:

| System | Number of Modules | Number of Mounts | Rail Length [m] | Mount Distance a [m] | Rail Cantilever b [m] | Module Cantilever c [m] |
|----------|-------------------|------------------|-----------------|----------------------|-----------------------|-------------------------|
| SSM1 1.2 | 1 | 2 | 1.50 | 1.00 | 0.25 | 0.08 |
| SSM1 1.3 | 1 | 3 | 1.50 | 0.60 | 0.15 | 0.08 |
| SSM1 2.2 | 2 | 2 | 3.00 | 1.90 | 0.55 | 0.17 |
| SSM1 2.3 | 2 | 3 | 3.00 | 1.17 | 0.33 | 0.17 |
| SSM1 2.4 | 2 | 4 | 3.00 | 0.90 | 0.15 | 0.17 |
| SSM1 3.3 | 3 | 3 | 4.50 | 1.78 | 0.47 | 0.26 |
| SSM1 3.4 | 3 | 4 | 4.50 | 1.34 | 0.24 | 0.26 |
| SSM1 3.5 | 3 | 5 | 4.50 | 1.00 | 0.25 | 0.26 |
| SSM1 4.4 | 4 | 4 | 6.00 | 1.90 | 0.15 | 0.35 |
| SSM1 4.5 | 4 | 5 | 6.00 | 1.42 | 0.16 | 0.35 |
| SSM1 4.6 | 4 | 6 | 6.00 | 1.14 | 0.15 | 0.35 |
| SSM1 4.7 | 4 | 7 | 6.00 | 0.95 | 0.15 | 0.35 |

Table 1: Components and dimensions (with 60-cell modules with a long length of 1.66 m)

Note: Due to thermal expansion, an additional distance of 20 mm must be added between the systems ($d_{\text{theoretical}} + 20 \text{ mm}$).

Rail distance calculation $d = c_L + c_R + 20 \text{ mm}$

| | SSM1 1.x | SSM1 2.x | SSM1 3.x | SSM1 4.x |
|----------|----------|----------|----------|----------|
| SSM1 1.x | 0.18 | 0.27 | 0.36 | 0.45 |
| SSM1 2.x | 0.27 | 0.36 | 0.45 | 0.54 |
| SSM1 3.x | 0.36 | 0.45 | 0.54 | 0.63 |
| SSM1 4.x | 0.45 | 0.54 | 0.63 | 0.72 |

Table 2: Rail distance d (with 20 mm distance)

3 Using the hammer-head screw and twist protection

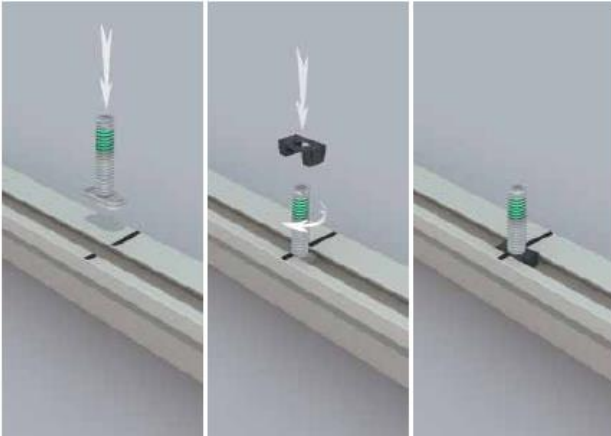

Place the hammer-head screws (M10 thread) on the marked places into the groove and twist them a little clockwise to prevent them from falling out. Place the twist protection on the hammer-head screw. Now fix the twist protection in the groove.

The hammer-head screws are fitted with a micro-encapsulated adhesive and assume the function of the security nut. They can therefore only be used once.

4 Mounting of the front cap

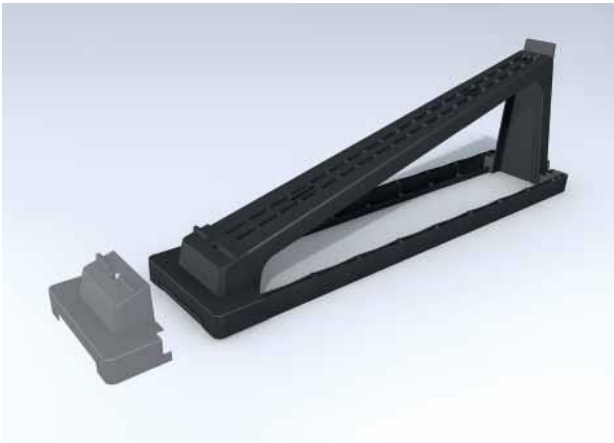

Put the front cap on the mounting racks.

5 Attaching Sika SolarClick fasteners and base plates

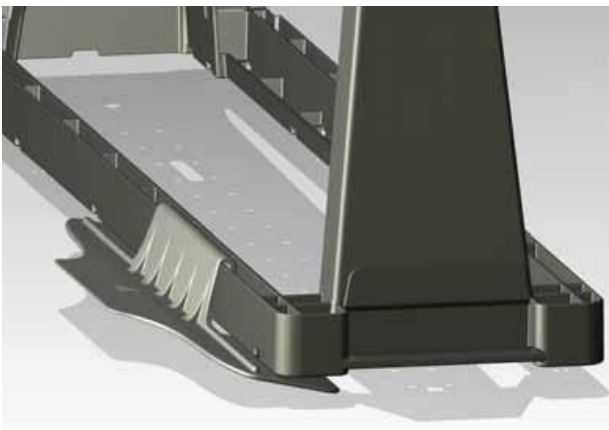

The mounting racks need to be secured against moving and sliding during use. According to the lay-out and design of the project, the Sika SolarClick fasteners are hooked into the lateral recesses of the racks.

Depending on the design by Centroplan either 2 or 4 Sika SolarClick have to be used per mount. In case of 2 Sika SolarClick they are always mounted at the higher end (North) of the mount.

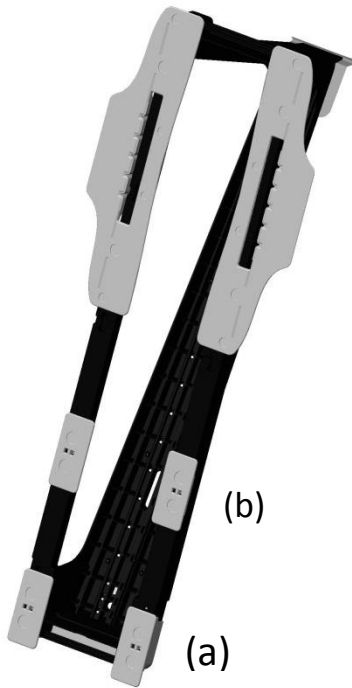

4 additional base plates are mounted to the underside of the mount, in case if only 2 Sika SolarClick per mount are used:

- 2 base plates are going to be hooked into the outermost recesses (a). The base plates shall protrude from the mount's end.
- The two other base plates are hooked into the third recess (b).

Positions see picture on the left

The Sika SolarClick and the base plates are available in the same material qualities as the respective Sika FPO and PVC Roofing membranes.

Option:



A metal clamp, perfectly matching with the shape of the Sika SolarClick, is used in case of higher temperatures or larger horizontal loads.

It is going to be fixed through the mount's web by 2 screws which are delivered with the clamp.

The clamps are used according to the detailed plans.

6 Rotating the mounting rack

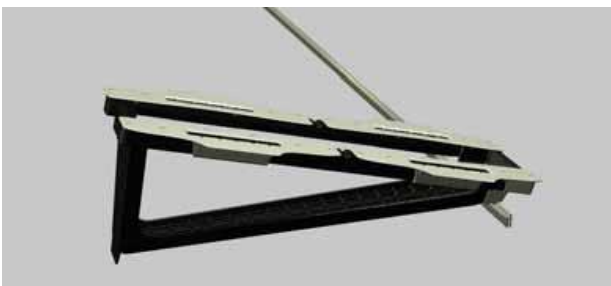

Prepare an assembly rail with the pre-assembled screws.

Turn the mounts with the Sika SolarClick and the UV cap upside-down and insert the hammer-head screws in the provided mounting aperture at the lower end of the mount (South).

Method Statement

Sika® SolarMount-1
Installation Manual SOUTH; Feb. 17, 2015, v 08

EN

Template für local adaption

7 Direction of the assembly rail ridge

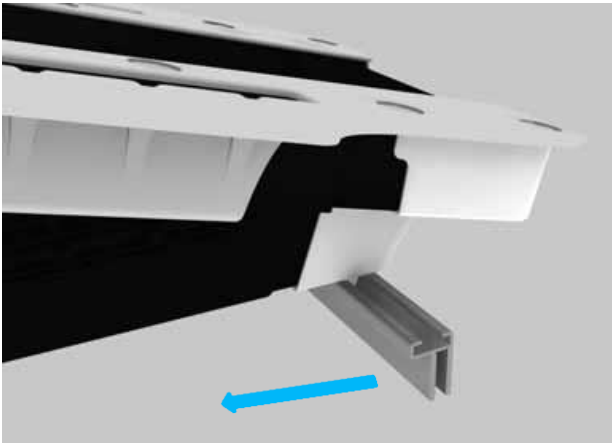

The ridge of the module assembly rail must be facing the centre of the mount.

8 Screwing the assembly rack

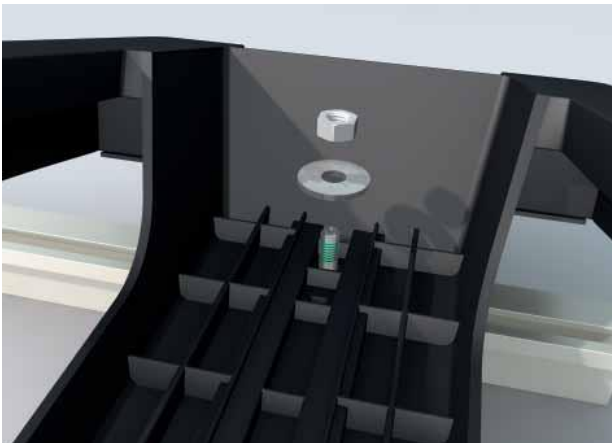

Fit the hammer-head screws with washers and nuts.

9 Tightening the nuts

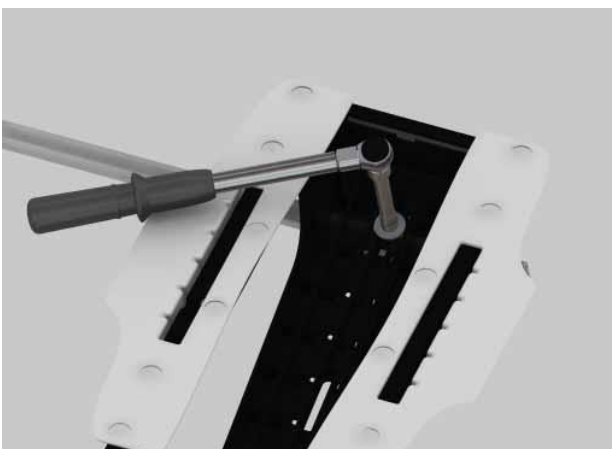

Tighten the nuts with a torque of 15 Nm.

10 Rotating the frame



Once all mounting racks are firmly connected to the assembly rail, these are placed back on foot by turning them by 180°.

11 Placing the wind deflector caps



Stick the wind deflector cap onto the mount nose.

12 Mounting the upper assembly rail



Place the second rail with pre-mounted hammer-head screw in the slots provided.

The ridge of the module assembly rail (see white arrow) must be facing the centre of the mount.

13 Inserting assembly jigs

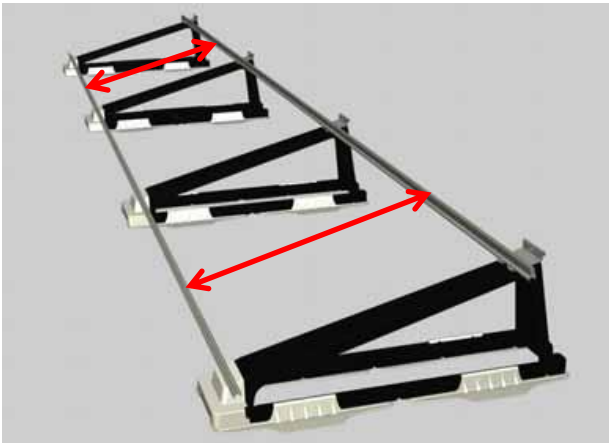

Insert assembling jigs with the width of a module (see red arrows let) on both sides between the mounting rails in order to establish the exact distance to one another, and then remove the jigs.

14 Fixing the hammer-head screw

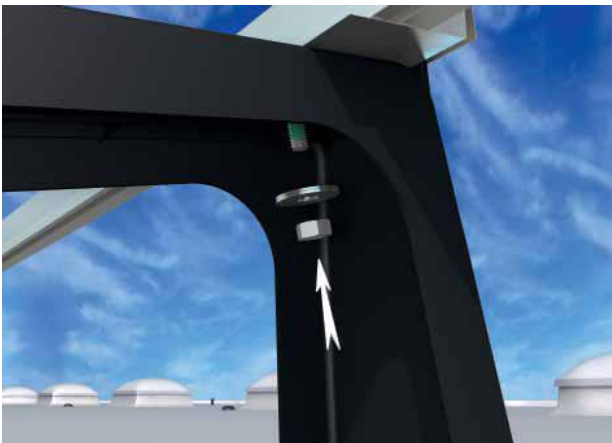

Fix the washer and the nut to the hammer-head screw.

15 Tightening the screw fitting



Tighten the nuts with a torque of 15 Nm.

16 Aligning the roof frame



Align the frame according to the roof configuration plan.

A setback of 1.5 m to the edge of the roof is to be maintained unless stated otherwise

17 Temporary flap fixing



Temporary 2-point fixing of the Sika SolarClick sections along the inner end with a handheld hot-air welding gun.

Special attention and care is required to avoid moving of the rack assembly during the welding process.

18 Hand welding process

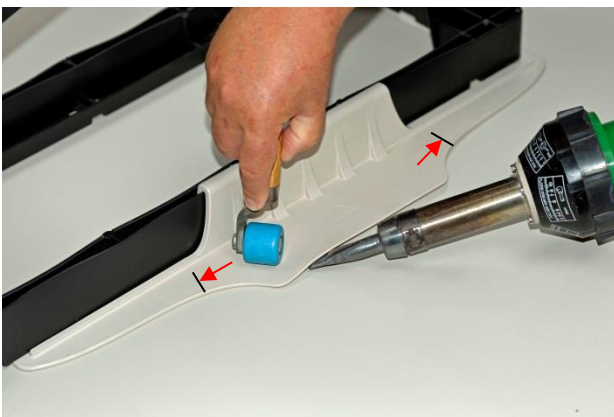

Hand welding of the flaps along the length of 280 mm between the arrow marks on the Sika SolarClick. The same welding process as for the relevant roofing membranes is used.

Welding parameters for FPO systems are as those used for **Sarnafil® T**; for PVC systems they should be the same as those used for **Sarnafil® G/S** or **Sikaplan®**.

Tools:

Handheld hot-air welding gun and rubber pressure roller.

19 Paving stone dimensions

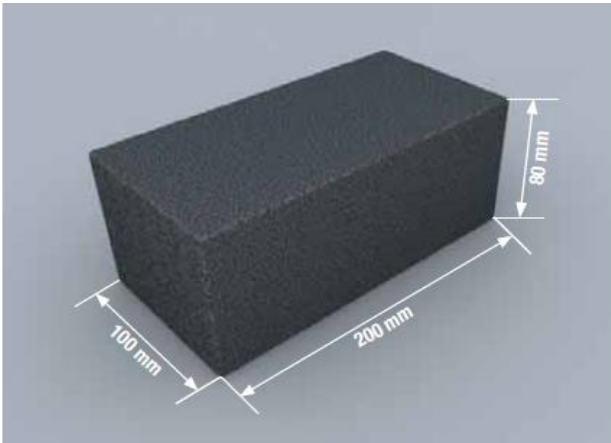

Ballasting is carried out according to the ballast plan with rectangle paving stones.

E.g. 200 x 100 x 80 mm; Weight: 3.6 kg, or
200 x 100 x 60 mm; Weight: 2.8 kg.

20 Ballasting

Stack the paving stones in the mounting rack. Fill up the lower part of the rack first before commencing a second layer.



Maximum number of stones per layer:
lower layer: 9, middle layer: 6, upper layer: 3

21 Module mounting

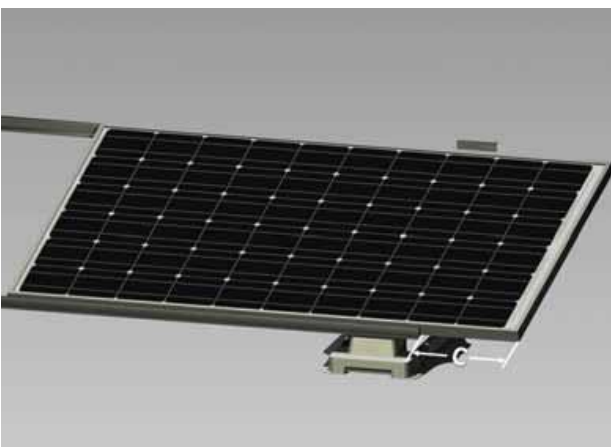

Lay the first module onto the bases of the module assembly rails and set up the module cantilever (c) according to the previous table or the layout plan.

The dimensions of the cantilever (c) can be taken from table 1 (depending on the variant) or from the lay-out plan.

22 Cable Connections

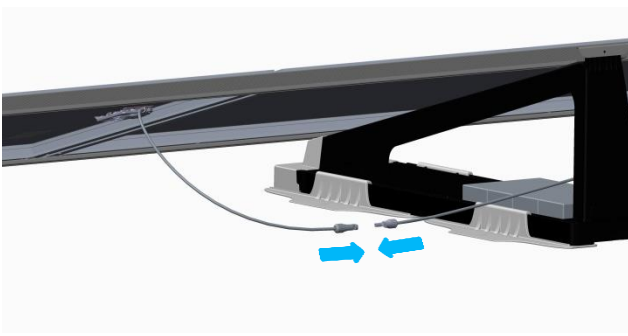

Interconnect the plugs while joining the modules.

23 Laying cables

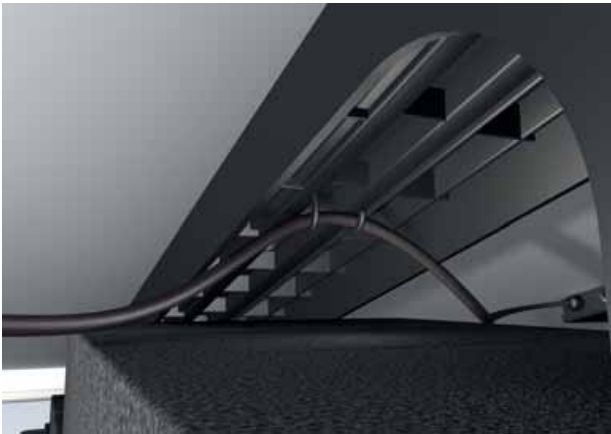

Insert the bundled cables into the mounts in the mounting racks. The cables shall not be allowed to swing, and the connectors may not be left on the roof as it may lead to leakage current due to ponding water.

As an option the module and the string cables can be fixed additionally with special cable straps and clips.

These straps and clips are not part of the SSM1 system but can be ordered from Centroplan.



a) Strap for module cables



b) Clip for string cables

a) The socket of the cable strap for the module



cables is clamped into the module frame.



- b) The clip for the string cables is attached in the groove of the assembly rail.

24 Module mounting

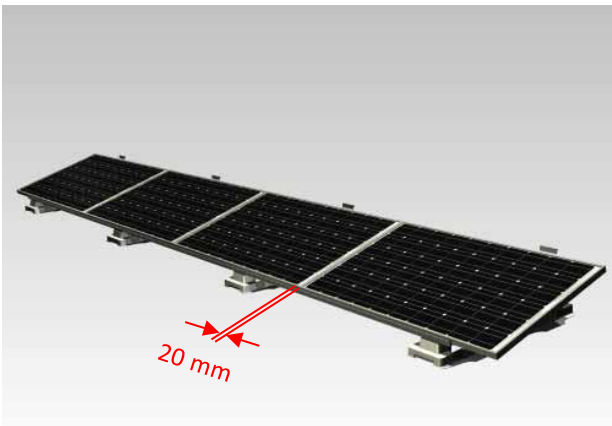

Insert the remaining modules with a distance of 20 mm to the adjacent modules. The junction boxes of the modules should face to the same side.

25 Positions of the module clamps

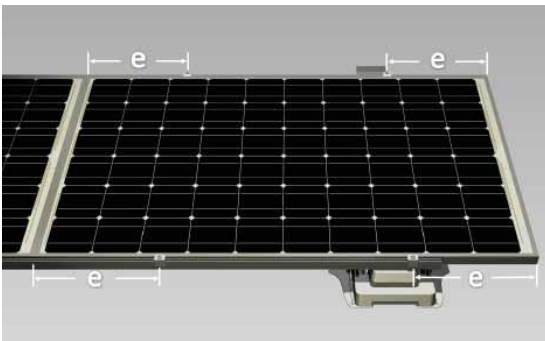

Each module is fixed in place with four module clamps.

The distance (e) of the clamps from the outer edge of the modules is according to the installation instruction of the PV module supplier.

26 Fastening module clamps

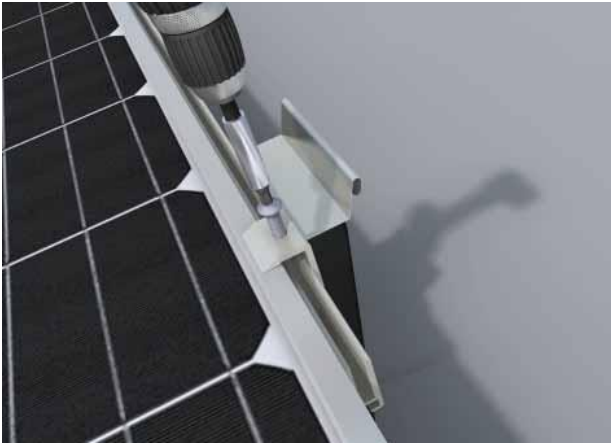

Fasten the 4 module clamp screws with a torque of 2 Nm.

Note:

If a screw hole is stripped or otherwise faulty, screw it in again offset a few centimetres to the side.

27 Inserting the wind deflector

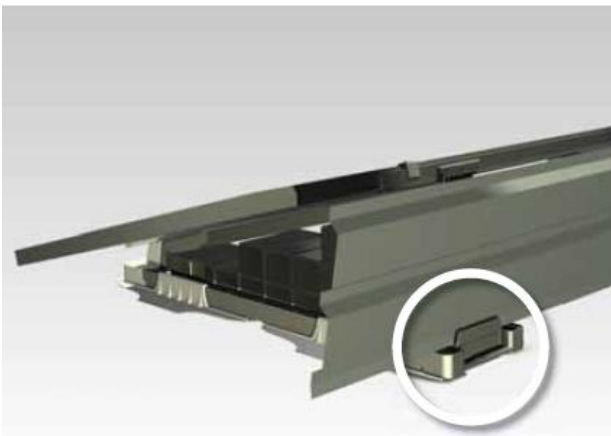

Insert the wind deflector sheet in the lip at the rear bottom of the rack. The sheet must fit flush with the outer edges of the module row.

Note:

The upper edge of the wind deflector sheet is marked.

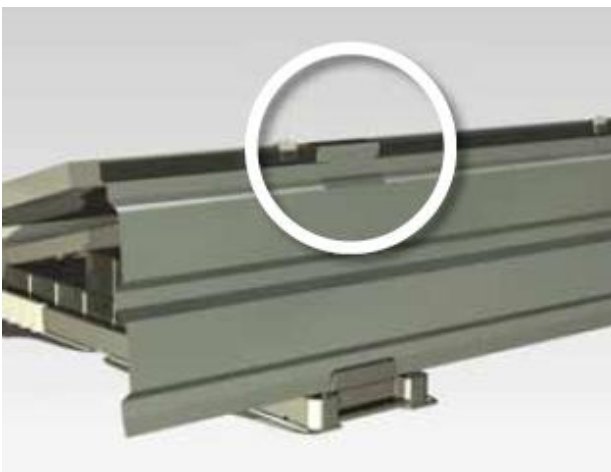

Press down the top of the wind deflector and insert the sheet under the wind deflector cap.

Caution:

The wind deflector may not be distorted irreversibly.

Note:

Wear protective gloves. The sheets may have sharp edges.

28 Screwing in the wind deflectors

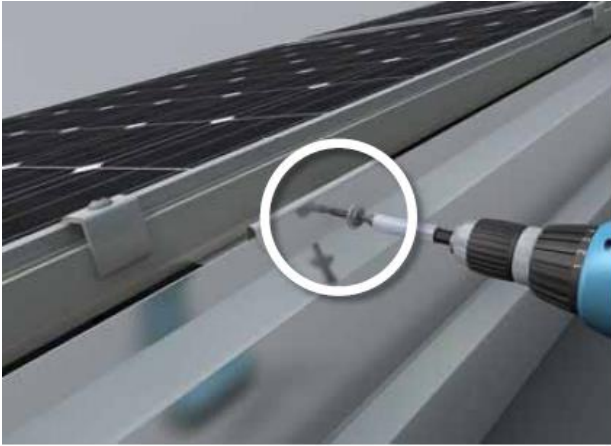

Fasten the wind deflectors in place using self-cutting thin sheet screws at each wind guide cap.

Note:

Don't over tighten the screws!

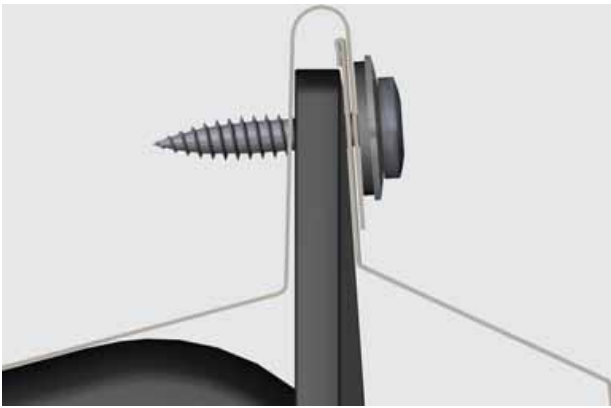

Cross-section of the wind deflector screw position.

Note:

Just the tip of the screw can show signs of surface corrosion after weathering. This has no negative influence to their function.

29 Wind deflector overlap

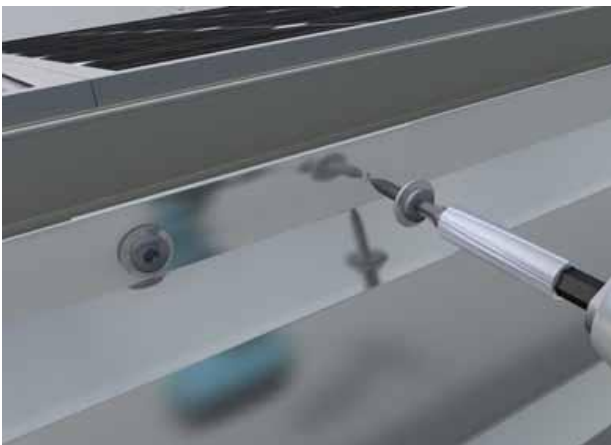

The individual wind deflectors must be connected at the overlap positions using self-cutting thin sheet screws fitting in the pre-drilled holes.

The minimum overlap of the sheets is 90 mm. The wind deflectors must be aligned such that the thin sheet screws in the area behind the wind guide have a distance of at least 20 mm to the edge.

Note:

Don't over tighten the screws!

Method Statement

Sika® SolarMount-1
Installation Manual SOUTH; Feb. 17, 2015, v 08

EN

Template für local adaption

30 Ready mounted PV generator, variant SSM1 4.4:



Method Statement

Sika® SolarMount-1

Installation Manual SOUTH; Feb. 17, 2015, v 08

EN

Template für local adaption



Method Statement

Sika® SolarMount-1

Installation Manual SOUTH; Feb. 17, 2015, v 08

EN

Template für local adaption



Our most current General Sales
Conditions shall apply.
Please consult the Product Data Sheet prior to any use and processing.

Sika Services AG
Roofing
Speckstrasse 22
CH-8330 Pfaeffikon
Switzerland
www.sika.com

Method Statement
Sika® SolarMount-1
Installation Manual SOUTH; Feb. 17, 2015, v 08

EN
Template für local adaption