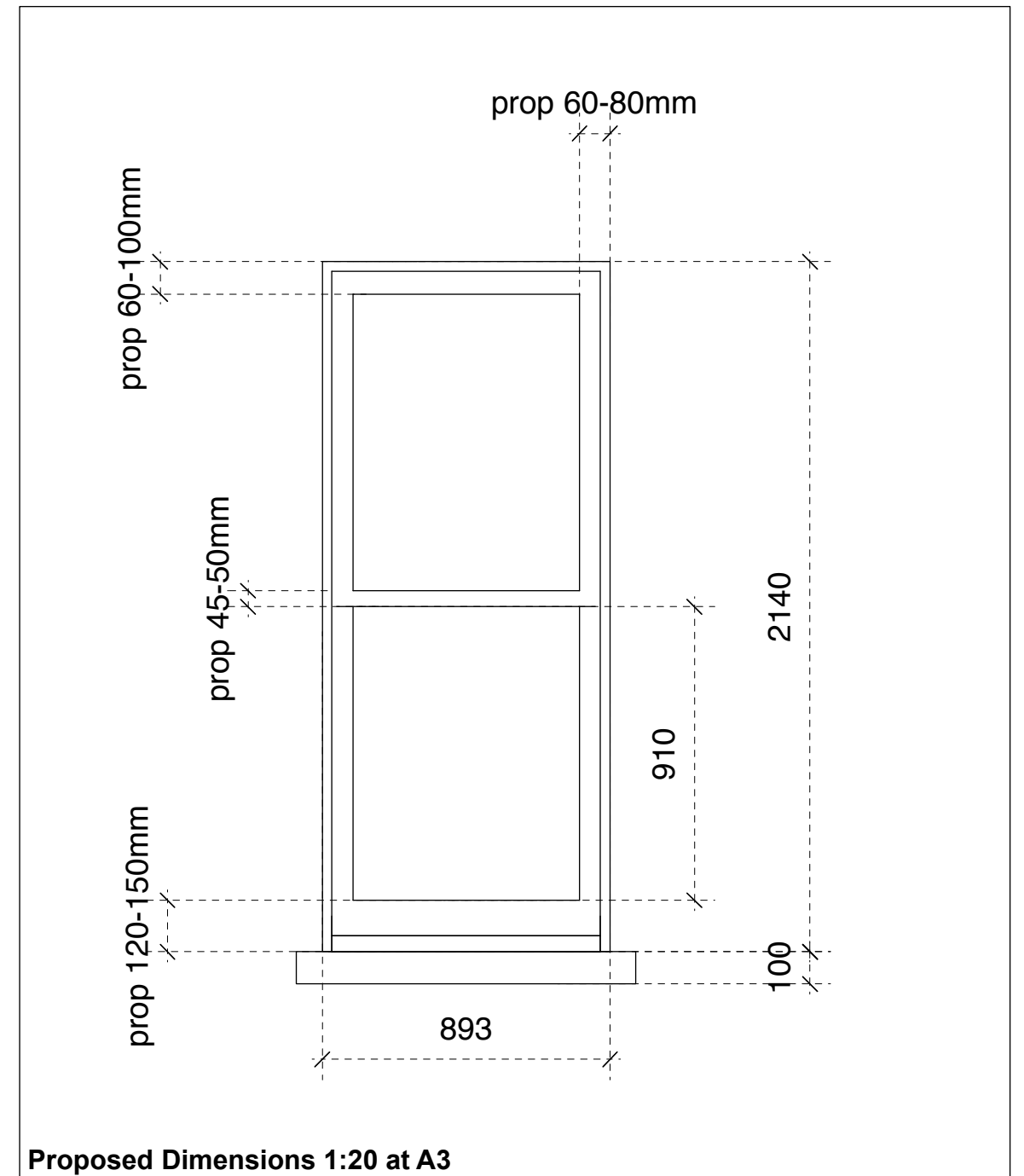



Photo of Typical Proposed Replacement Windows



Notes	This drawing is copyright. All dimensions to be checked on site and any discrepancy, error or omission reported to the architect.		
Project	2 Langland Mansions, NW3 6QA		
Client	Lynda & Steven Loble		
Date	27.07.17	Scale	1:20 at A3
Drawing Title	Photo of Typical Proposed Replacement PVC-U Sash Window & Typical Dimensions to IProposed Windows		
Drawing Status	App for Certificate of Lawful Development	Drawing No.	LM 006