

EXISTING

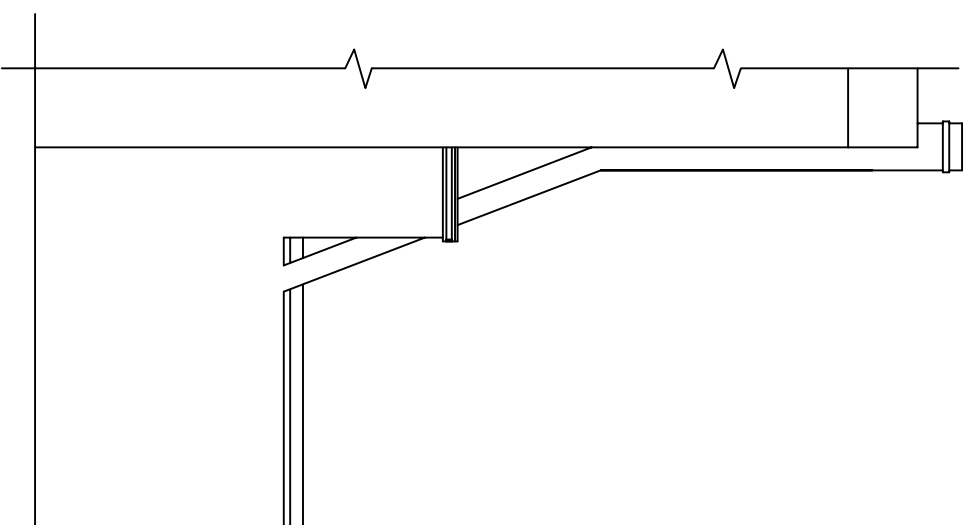

SIDE ELEVATION

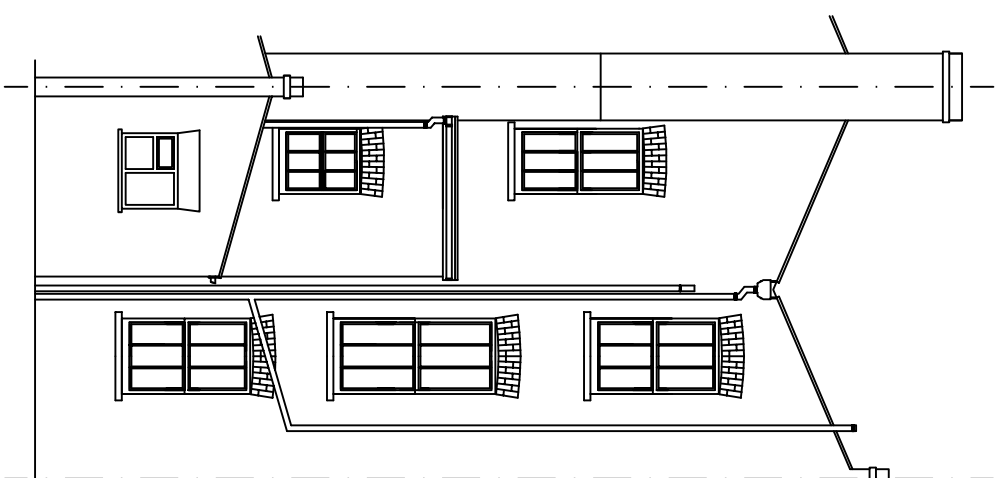

REAR ELEVATION

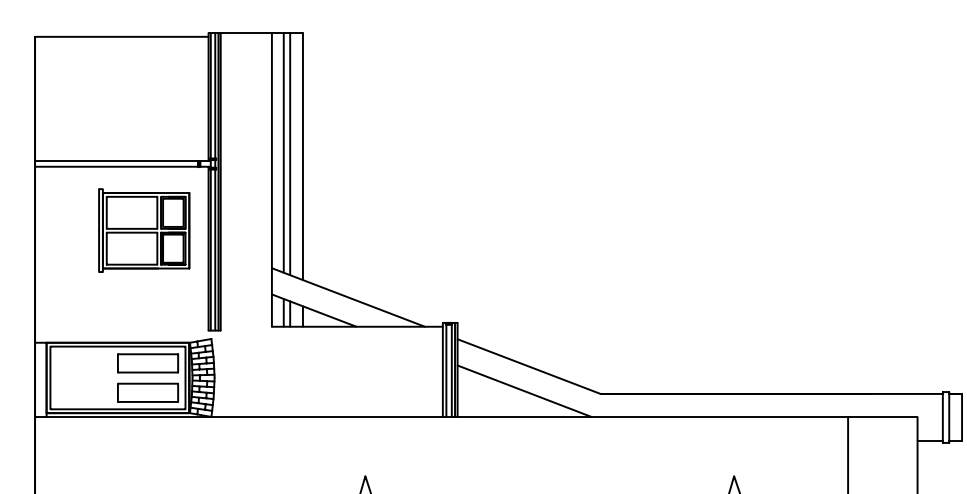

SIDE ELEVATION

Drawings :- EXISTING ELEVATIONS

Project :-
**PROPOSED SINGLE AND THREE STOREY
REAR EXTENSION AND INTERNAL ALTERATIONS**

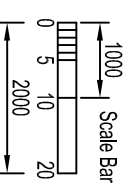

Project / Property Address :-
57 FALKLAND ROAD, LONDON, NW5, 2XB.

Client's Name / Details :-
**Mr Kerim Yildiz
57 FALKLAND ROAD,
LONDON, NW5, 2XB.**

Scale @ A3:-	Date:-	Agent / By:-
1:100 @A3	26/07/17	RDCBDS LTD
Drawing No:-	Sheet No:-	Rev:-
RDC/57/003	3 of 4	-

Agents Emails details :-
Richard.Clark16@virginmedia.com

Agents contact details :-
Mobile Tel No :- 07880750825

All items, notes dimensions and general design contained on this drawing shown are for guidance purposes. Nominated Builder or person responsible for the project should make a thorough check prior to commencement of works against the site, drainage services drawings, current Building Regulations, British Standards and Codes of Practice. The originator (RDCBDS Ltd) will NOT accept any liability for mistakes that could occur. All dimensions are to be checked on site before any work are put in hand and before materials are ordered.