

CAR PARK SIGN - BACK ELEVATION

SCALE 1:50 @A3

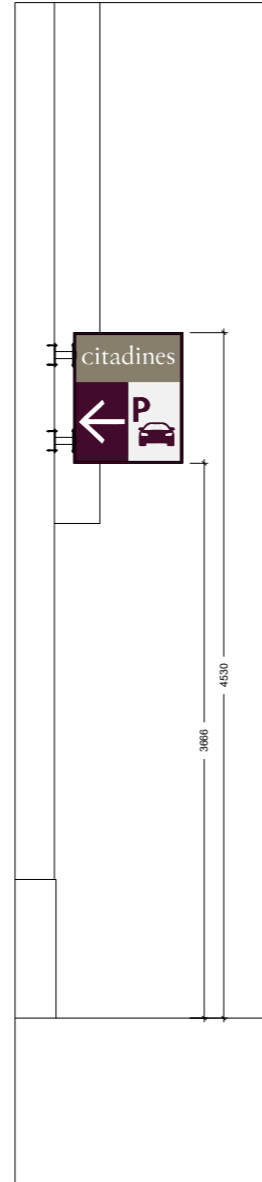

SIDE ELEVATION

SCALE 1:50 @A3

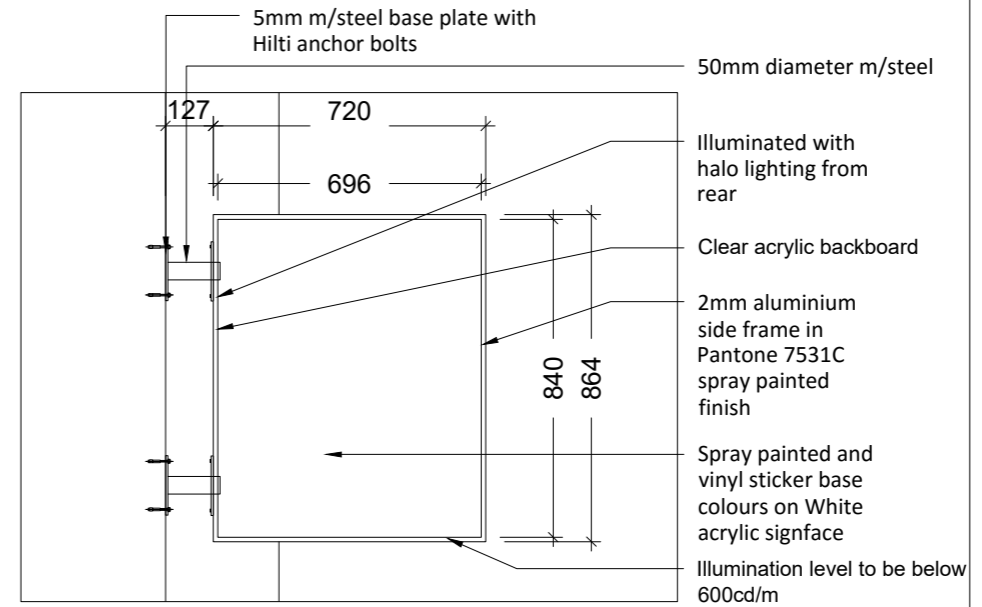

DETAIL A - FRONT SECTION

SCALE 1:20 @A3

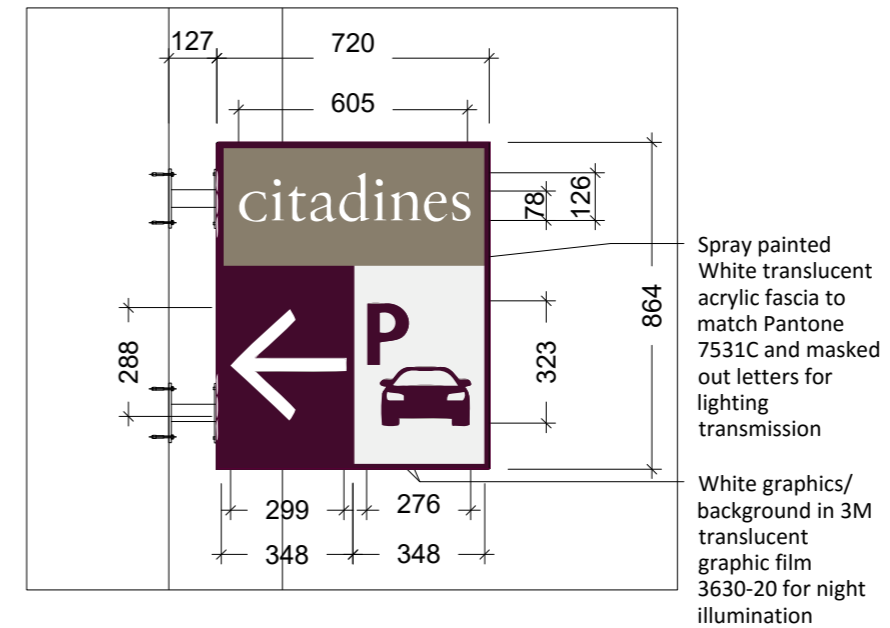

DETAIL A - GRAPHIC

SCALE 1:20 @A3

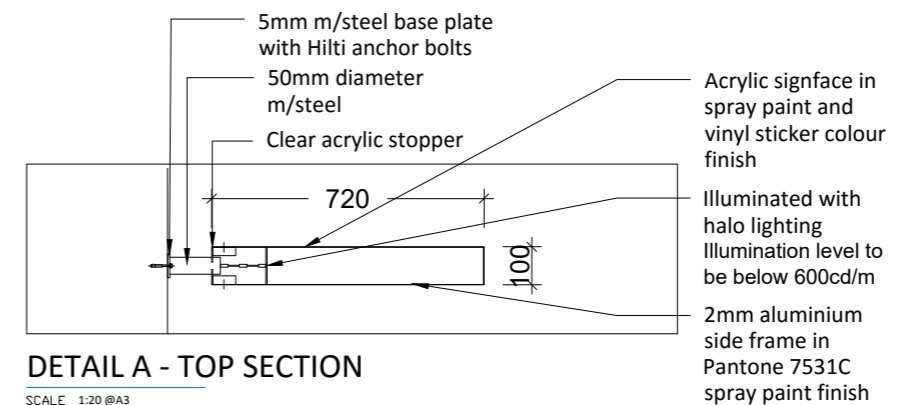

DETAIL A - TOP SECTION

SCALE 1:20 @A3

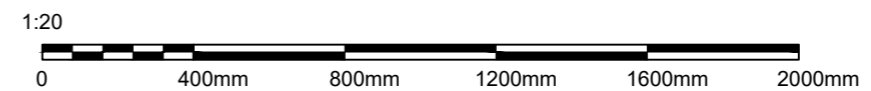

NOTES

1. This drawing remains the copyrights of Chapman Workhouse Architects. Do not copy, transfer or re-assign this drawing in digital or hardcopy format to a third party without written consent of Chapman Workhouse Architects.
2. Do not scale from drawings. Only use stated dimensions. Check all dimensions on site and please report any discrepancies to architect.
3. Drawings to be read in conjunction with other consultant's drawings and specifications.

KEY

KEY PLAN



DATE REV D.BY C.BY COMMENTS

17.05.2017	P1			PLANNING ISSUE
12.06.2017	P2			PLANNING ISSUE
20.07.2017	P3			PLANNING ISSUE

DESIGN DEVELOPMENT

Job CITADINES COVENT GARDEN
94-99 HIGH HOLBORN

Drwg PROPOSED SIGNAGE DETAILS

No. 1704-PL-706 P3

Scale various

Date 16.05.2017

chapmanwaterworth
architects + designers

Head Office: 75 Tottenham Street, London W1T 2LN
www.chapmanwaterworth.com