

23rd June 2017

Camden Local Planning Authority
FAO: Nora-Andreea Constantinescu
RE: 96 West End Lane
Ref: 2017/2593/P

Further to your recent communication, I would like to address the two points raised.

1. I can confirm that we will install 2 'Sheffield' cycle racks, for the provision of 4 bicycles, parallel to the rear wall/main entrance to the proposed gym. These will be situated in front of the disabled parking space. The cycle racks will be in the style shown below:

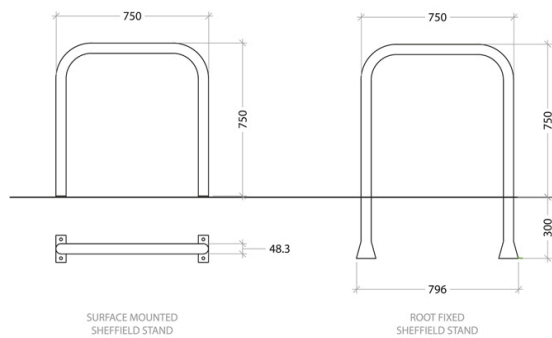

2. In regard to the question about the parking space, I can confirm that the space is entirely on land owned by the applicant and for the sole use of the application site. It is not general parking.

Kind regards,
Mr. A. Wilson BA Hons (Arch), PG Dip
Agent