

KEY PLAN:

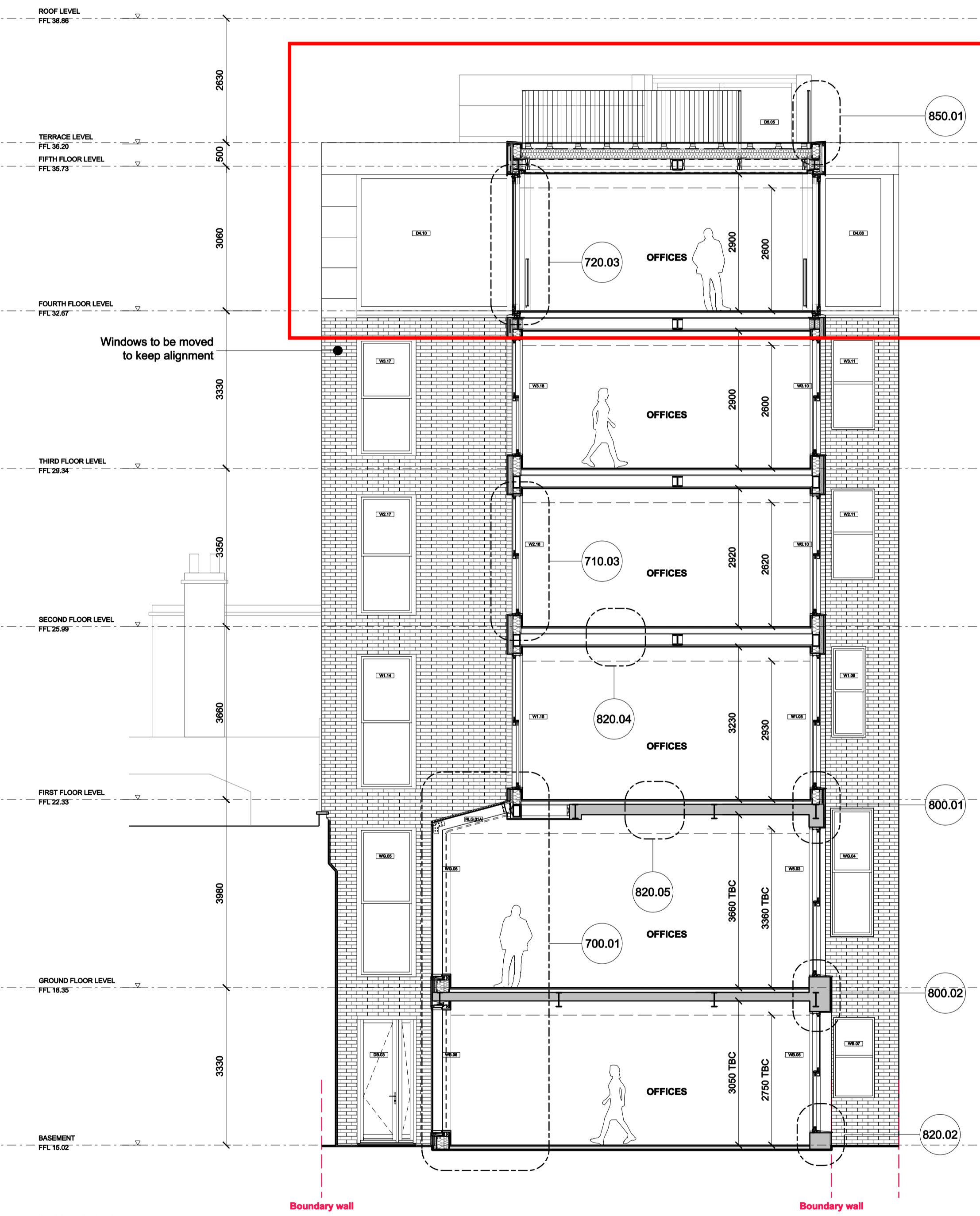

01. PROPOSED SECTION BB

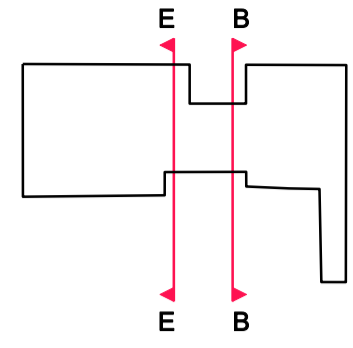
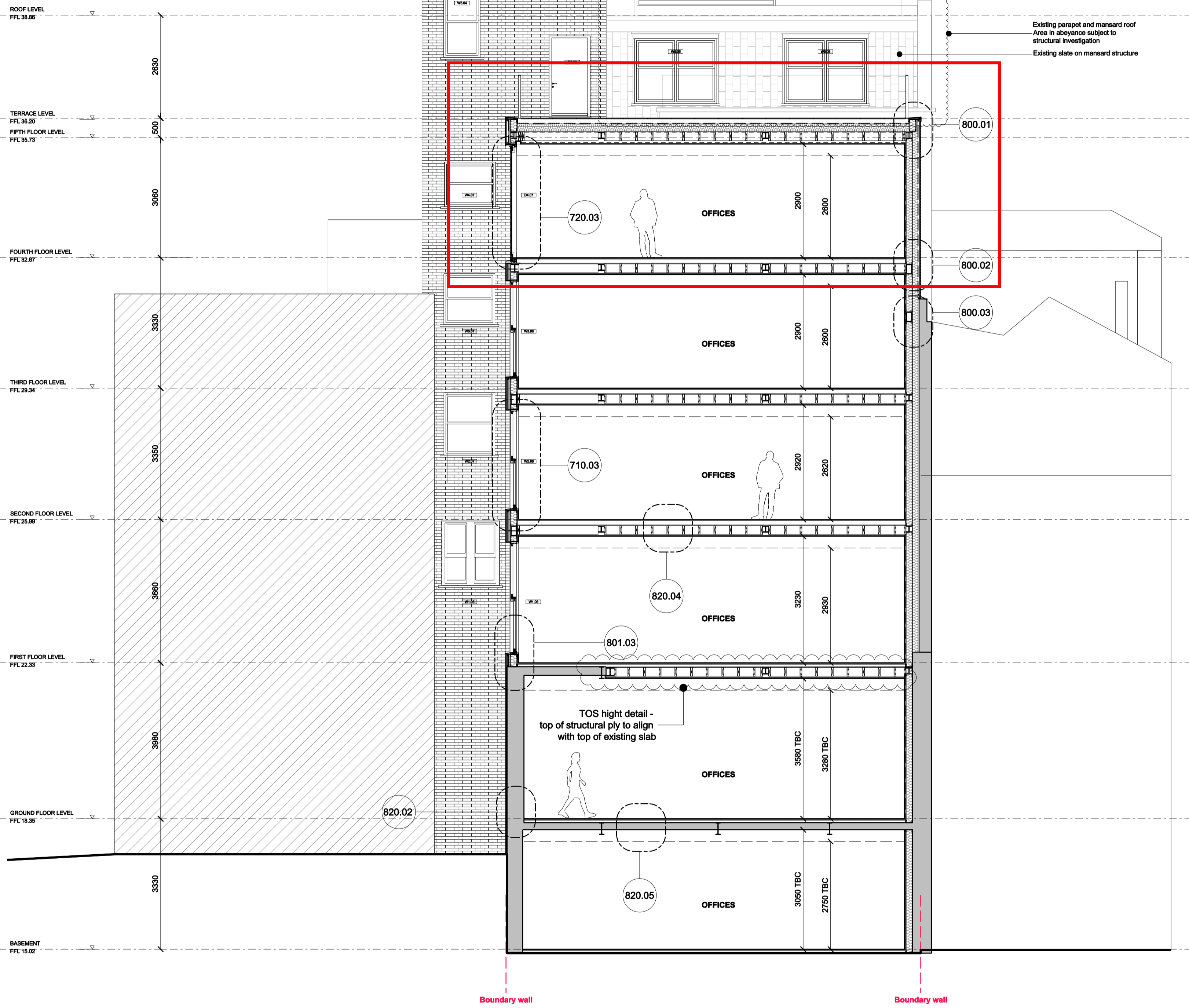

02. PROPOSED SECTION EE

28 HATTON GARDEN

MINERVA HOUSE

37 GREVILLE STREET

25A HATTON GARDEN

MINERVA HOUSE

28 HATTON GARDEN

REV.	DATE	DESCRIPTION
-	06.06.2016	FIRST ISSUE - PREPARATION TENDER
A	23.06.2016	UPDATES - PREPARATION TENDER
B	16.08.2016	UPDATED DRAWINGS - EXTENDED REAR STAIRCASE / AFFORDABLE JEWELLERY SPACE / ENLARGED WINDOWS / TOILETS / MECHANICAL RISERS
C	22.09.2016	ISSUED FOR COORDINATION
D	30.09.2016	ISSUED FOR TENDER
E	05.10.2016	ISSUED FOR TENDER
F	17.10.2016	ISSUED FOR TENDER
G	11.01.2016	REVISION FOLLOWING STRUCTURAL CHANGES

REV.	DATE	DESCRIPTION
H	09.02.2017	STAGE 5 ISSUE
I	28.02.2017	SETTING OUT - ISSUE 01

NOTES:

- ALL DIMENSIONS IN MM UNLESS OTHERWISE STATED
- THIS DRAWING IS TO BE READ IN CONJUNCTION WITH ALL RELEVANT CONTRACT DOCUMENTS
- THIS DRAWING IS TO BE READ IN CONJUNCTION WITH ALL ENGINEER'S DRAWINGS
- DO NOT SCALE FROM THIS DRAWING
- REPORT ANY ERRORS, CONTRADICTIONS, & OMISSIONS TO THE ARCHITECT AS SOON AS POSSIBLE
- WHEN THIS DRAWING IS ISSUED IN DWG FORMAT IT IS AN UNCONTROLLED VERSION ISSUED TO ENABLE THE RECIPIENT TO PREPARE THEIR OWN DRAWINGS FOR WHICH THEY ARE SOLELY RESPONSIBLE. IT IS BASED ON BACKGROUND INFORMATION CURRENT AT TIME OF ISSUE. BEN ADAMS ARCHITECTS ACCEPTS NO LIABILITY FOR ANY SUCH ALTERATIONS OR ADDITIONS TO OR DISCREPANCIES ARISING OUT OF CHANGES TO SUCH BACKGROUND INFORMATION WHICH OCCUR AFTER IT IS ISSUED BY BEN ADAMS ARCHITECTS.

KEY:

Ben Adams Architects

Third Floor
99 Southwark Street
London SE1 0JF
T 020 7633 0000
benadamsarchitects.co.uk
info@benadamsarchitects.co.uk

DRAWING NAME: **PROPOSED SECTIONS BB AND EE**

PROJECT NAME: **MINERVA HOUSE**

DRAWING NO: **A501/I**

JOB NO: **15-035**
SCALE: **1:50 @ A0**
STAGE: **STAGE 5**