

Ground Floor Plan as Proposed
1 : 50

John Street

Issue:

PLANNING

- Key:**
- Existing
 - ▨ Proposed Walls
 - ▨ Proposed Partitions
 - ▨ Proposed Floor
 - ▨ Infill Existing Opening with Construction to match Existing where indicated on Drawing
 - Existing Footprint
 - - - Boundary Line

- F.E. Fire Exit
- 1 New Brickwork to match Existing
 - 2 New Aluminum Windows to match Existing
 - 3 New Curtain Walling
 - 4 New Metal Stairs
 - 5 New Composite Metal Cladding
 - 6 New Glass Canopy
 - 7 New Double Glazed Doors
 - 8 New Aluminium Bi-Folding Doors
 - 9 New Glass balustrade
 - 10 New Roof Hatch
 - 11 Extend External Ductwork
 - 12 Louvres to new Plant Enclosure
 - 13 Composite Metal Capping
 - 14 Brise soleil
 - 15 Frosted Frameless Glass

EXISTING FLOOR PLAN LAYOUTS ARE INDICATIVE
DRAWINGS FOR APPROVAL

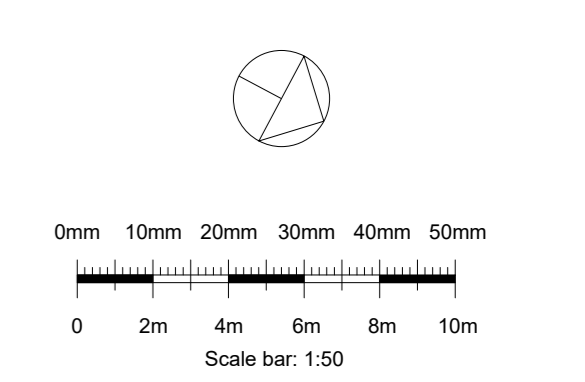

No scaled dimensions to be taken from this drawings. All dimensions to be site checked.

Revisions			
Rev.	Description	Drawn by	Date

CG ARCHITECTS
221 East Barnet Road, Barnet, Herts EN4 8QS
Tel: 020 8449 5100 Fax: 020 8449 5170 ©

Client
Metrus

Site
21A John Street
London WC1N 2BG

Scale: 1 : 50@ A0 Drawn: SH
Date: May 2017 Checked:CG

Drawing Title
Ground Floor Plan as Proposed

Drg No 1113/26 REV