

NOTE:
THIS DRAWING IS SUBJECT TO COPYRIGHT
ALL DIMENSIONS SHALL BE CHECKED ON SITE AND THE ARCHITECT
SHALL BE NOTIFIED OF ANY DISCREPANCIES PRIOR TO WORK
COMMENCING.

PLANS HAVE BEEN BASED ON CAD DATA PROVIDED BY THE CLIENT
WHICH HAS NOT BEEN CHECKED FOR ACCURACY

NOTES:

KEY:

1. New condensers to be wall mounted
2. New ducts and fans
3. New riser with metal sheet cladding
4. New gantry
5. New timber screen above plant area - Pergola approx 3 meters above Finish Floor Level
6. Existing Air Cooled Chiller
7. New Air Cooled Chiller in acoustic housing connected to existing pipe work
8. New Air Handling Unit to connect to existing rerouted pipework to suit
9. Existing ducts
10. New galvanised mild steel access ladders

KEY PLAN

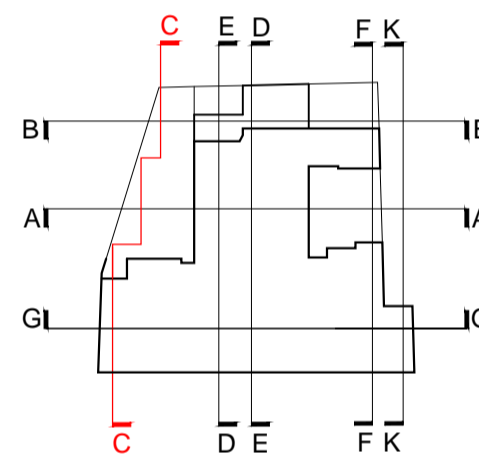

NO.	DESCRIPTION	DATE	DR BY
REVISIONS			
P1	First Issue	24.04.17	CD

THIS DRAWING SUBJECT TO COPYRIGHT

CLIENT
SHIVA KINGSWAY LTD

PROJECT
KINGSWAY HALL HOTEL

TITLE
SECTION CC
PROPOSED - PLANNING

DATE
24.04.2017

SCALE @ A1
1/100

JOB NO
CD

DRAWING NO
213

REVISION
P1

rayholearchitects
9th floor, 89 park lane
croydon, london
CR0 1JD
Tel: +44 (0) 20 8662 4600
Email: info@rh-architects.com

