

Sign Type B

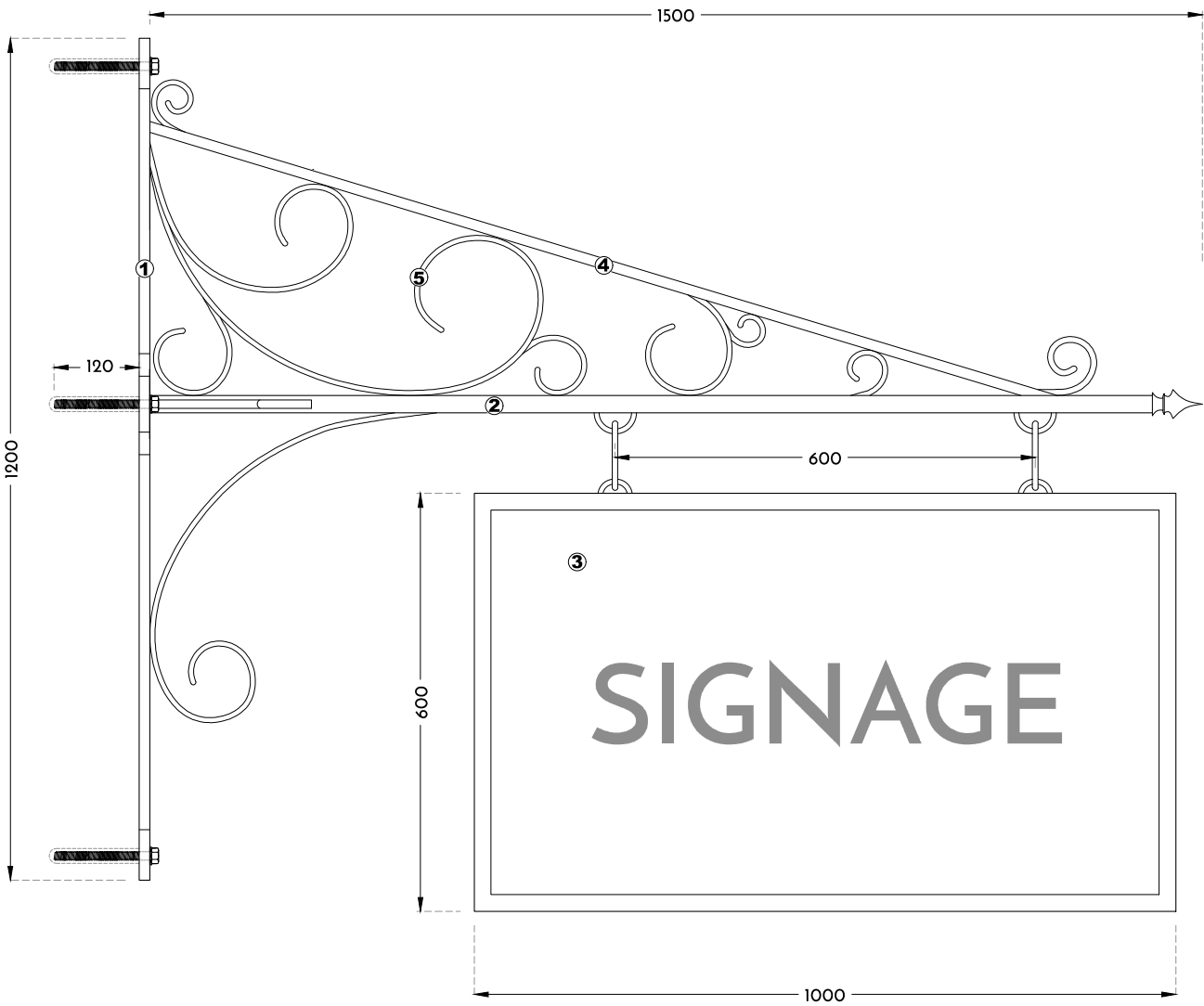

- ① Wrought iron fixing bracket approx 15thk, painted matt black. Drilled for bolting to existing brickwork wall with 4no. M12 S/S Bolts with 120mm embedment into HILTI HIT-HY 70 resin anchor or similar. Heads painted matt black. Drilled to receive bolts connecting fixing plate.
- ② 25mm steel barrel welded to wrought iron fixing bracket at one end, cast iron finial welded to other end. Matt black paint finish. Steel loops welded to underside at 600 spacing for chain/cable connection to sign board.
- ③ 25mm block board with 2mm steel lip to give finished overall size of 1000x600mm. Decorated by incoming tenants. Steel loops/hooks fixed to top edge at 600 space for chain/cable connection to steel barrel.
- ④ Wrought iron 15x15mm profile welded between steel barrel and brackets.
- ⑤ Wrought iron 15x8mm profile scrollwork, shaped as shown and welded in place.

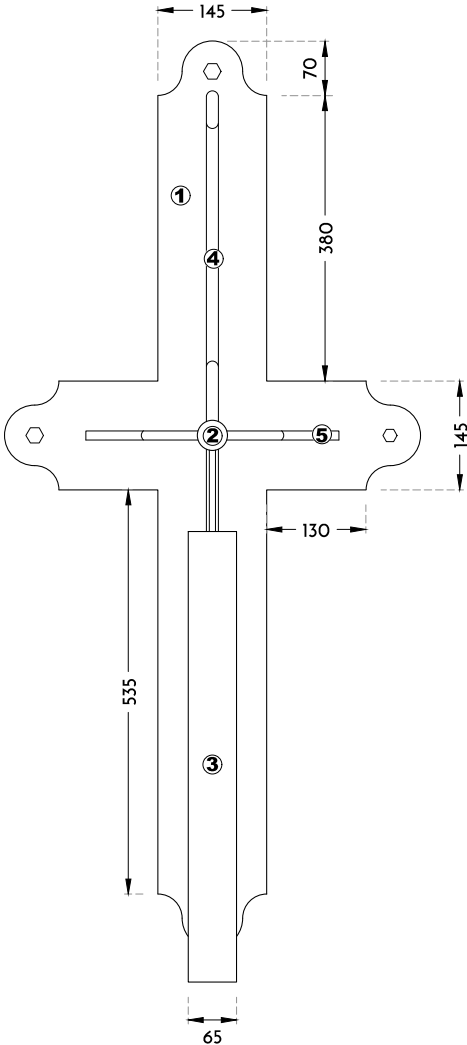
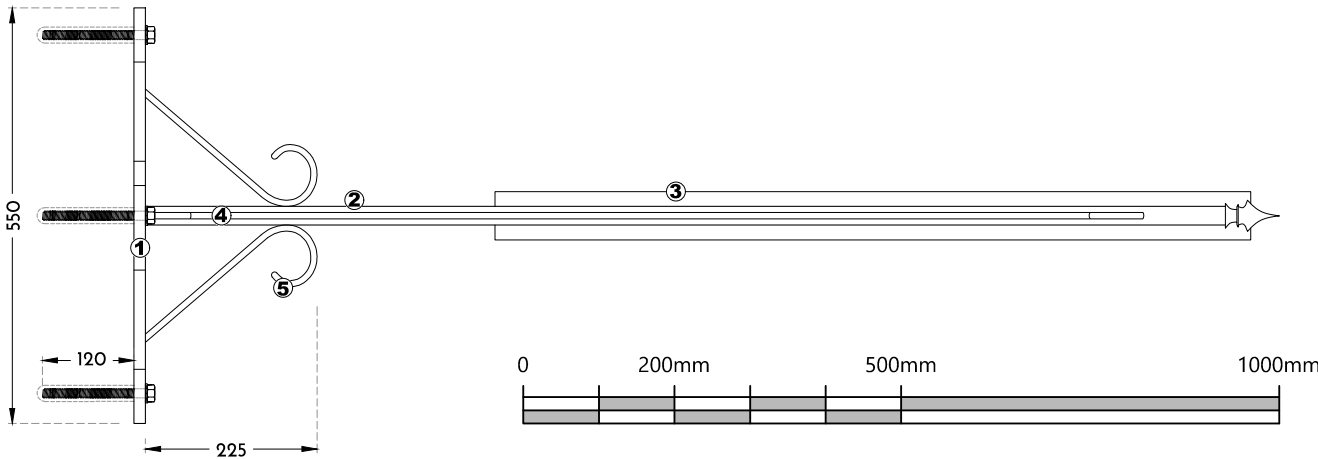

NOTES:
LOCATION PLAN @ 1:1250 SCALE & NORTH UP^.
ALL SCALES/DIMENSIONS TO BE CHECKED ON SITE.

REV	D.B.	DESCRIPTION	DATE
/	RJS	Initial Issue	26/04/2017
A	RJS	Fixing Details Amended	15/05/2017

Fresson & Tee
CHARTERED SURVEYORS

1 Sandwich Street
London WC1H 9PF
020 7391 7100
www.fandt.com

PROJECT NAME	Hanging Signage Application
DRAWING TITLE	SIGN TYPE B DETAILS

CLIENT	Shaftesbury Covent Garden Ltd.
ADDRESS	61-63 Monmouth Street, London, WC2

JOB NO.	20321
DRAWING NO.	P013-A
SCALE	1:10@A3
DATE	Apr. 2017