

Gundry

26 Earlham Street
Planning conditions

+

Ducker

Gundry & Ducker Architecture Ltd.
3 Garrick Street
London WC2E 9BF
United Kingdom

+44(0)20 3417 4895
info@gundryducker.com

CONTENTS

BASEMENT	3-4
GROUND FLOOR	5-6
FIRST FLOOR	7-8
SECOND FLOOR	9-10
THIRD FLOOR	11-12
STAIR JOINERY	13-14
DETAIL OF TYPICAL TRADITIONAL PANELLED DOOR	15
DETAIL OF TYPICAL WC DOOR	16
TYPICAL PLASTER BOARD WALL DETAIL (PARTITIONS)	17
DETAIL OF TYPICAL TRADITIONAL SKIRTING	18
WINDOW JOINERY	19

BASEMENT

FLOORING



Existing: Modern Red Quarry tiles to be retained.



Proposed: Floating ply flooring overlaid on existing to receive Altro Safety flooring.

CEILING

NO WORKS- DECORATE ONLY

BASEMENT PLAN

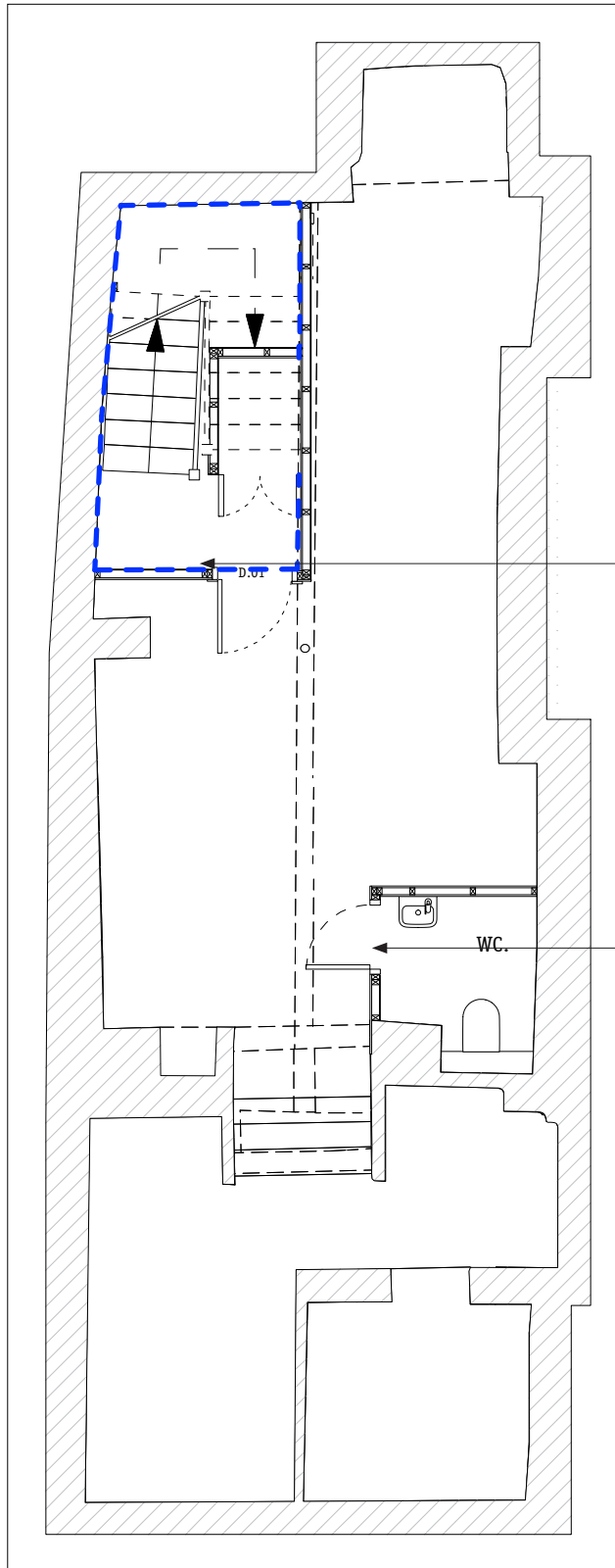

Refer to typical panelled door, p15.

Refer to typical WC door, p16.

LEGEND

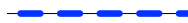
 To receive traditional skirting detail. Refer to page 18 for typical skirting detail.

Gundry

+

Ducker

GROUND FLOOR

FLOORING



Existing: Modern concrete slab.

Where the hole for the old staircase has been patched, the new joists will receive plywood.



Proposed: In-situ Bespoke Terrazo finish over existing concrete (Note traditional shop floor finish) with brass strips.

CEILING



Existing: 2no. layers plasterboard screwed to joists with Artex finish.

Proposed: Plasterboard to be patched or replaced like for like with smooth plaster skim.

GROUND FLOOR PLAN

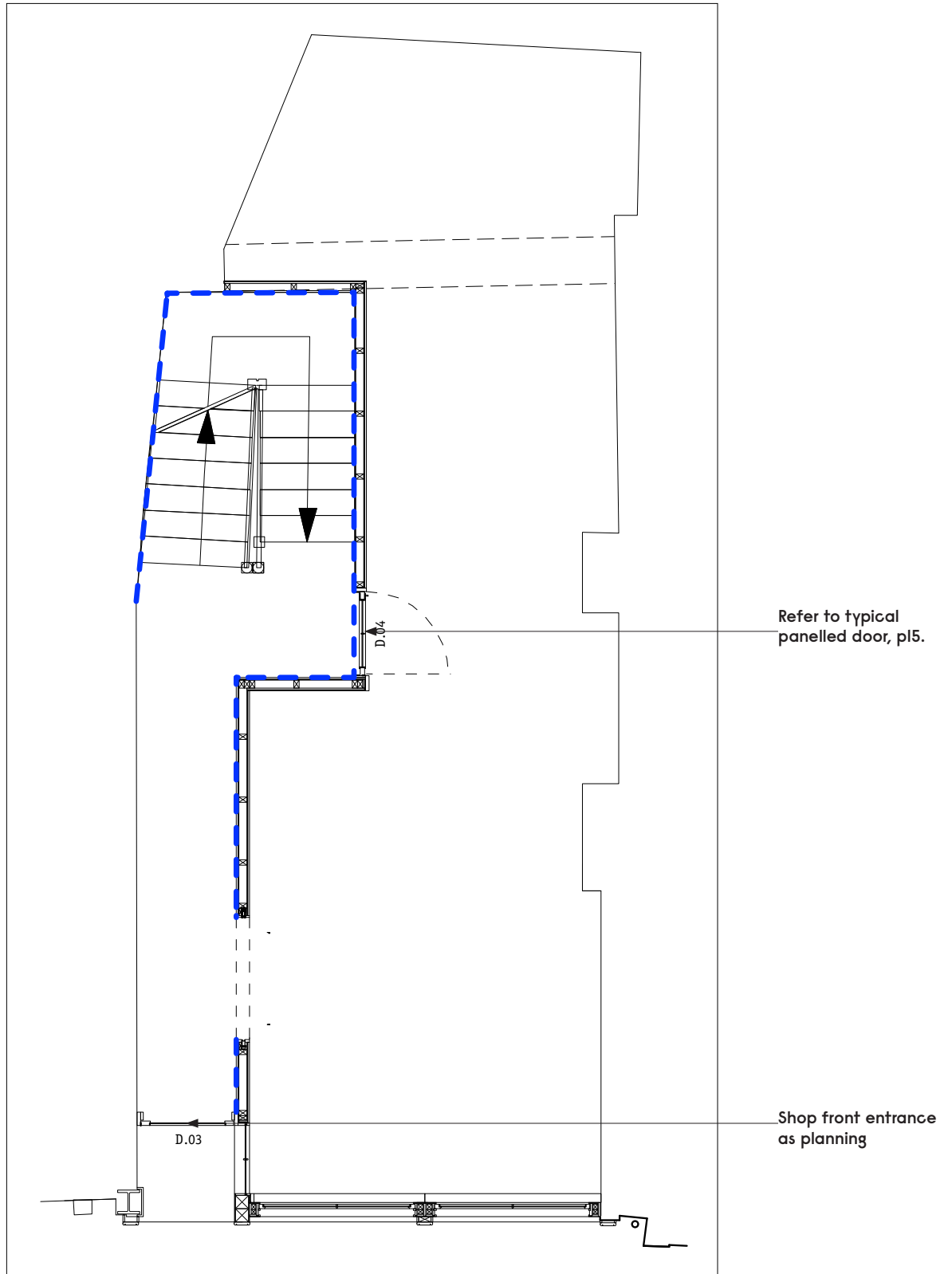

LEGEND

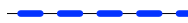
 To receive traditional skirting detail. Refer to page 18 for typical skirting detail.

Gundry

+

Ducker

FIRST FLOOR

FLOORING



Existing: Plywood fixed to existing joists.

Where the hole for the old staircase has been patched, the new joists will receive plywood.



Proposed: The existing ply will receive a floating 220mm Elm timber floor boards.

CEILING



Existing: 2no. layers plasterboard screwed to existing joists with woodchip wall paper finish.

Proposed: Patch and replace plasterboard where required strip wallpaper and decorate.

FIRST FLOOR PLAN

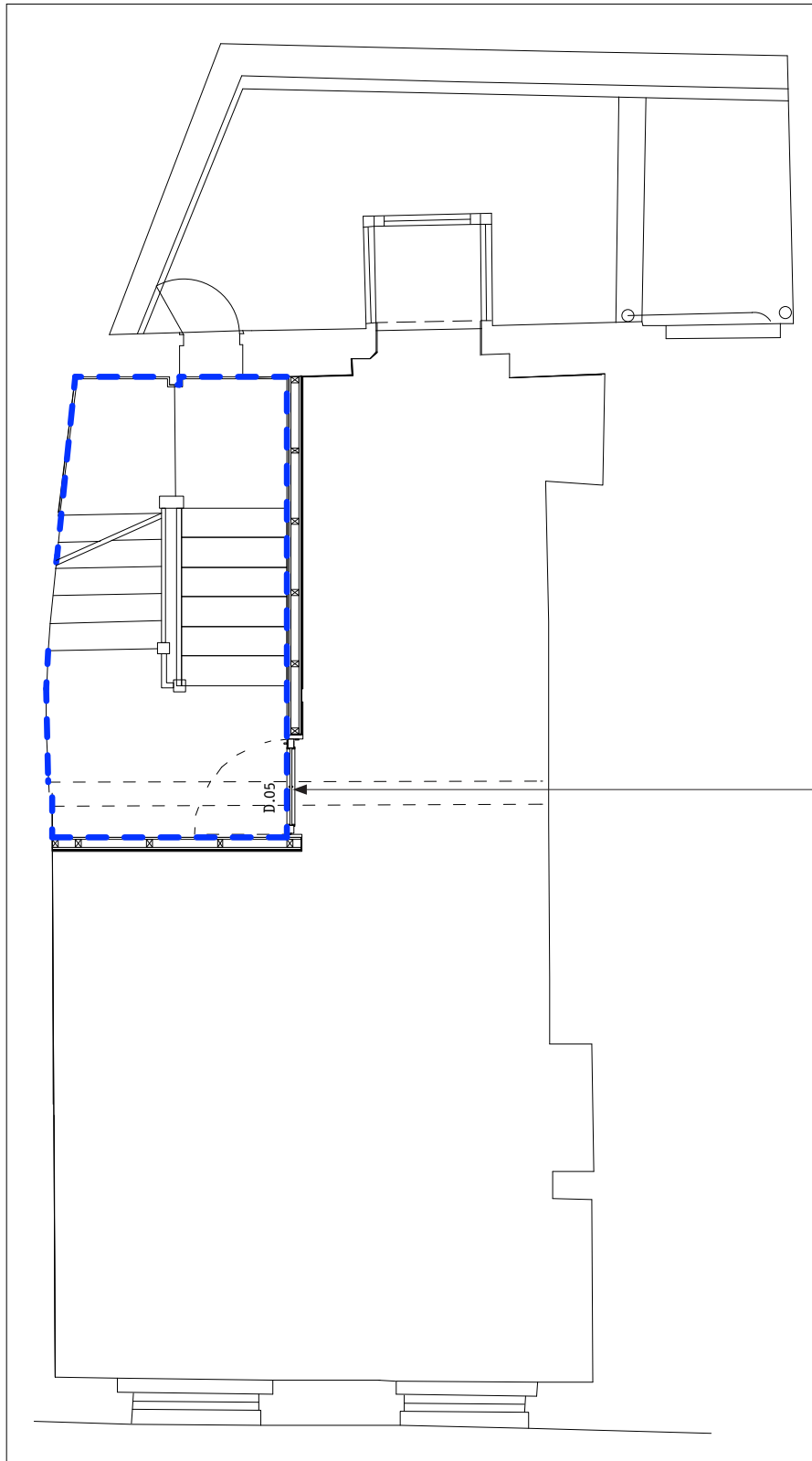

LEGEND

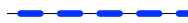
 To receive traditional skirting detail. Refer to page 18 for typical skirting detail.

Gundry

+

Ducker

SECOND FLOOR

FLOORING



Existing: Modern plywood fixed to joists.

Proposed: Finish: Floating timber floor over existing ply.



Proposed: Where holes in floor need to be patched ply to match existing. The existing ply will receive a floating 220mm Elm timber floor boards.

CEILING



Existing: 2no. layers of plasterboard skim with wall paper finish.

Proposed: Wallpaper to be stripped off and redecorate holes to be patched.

SECOND FLOOR PLAN

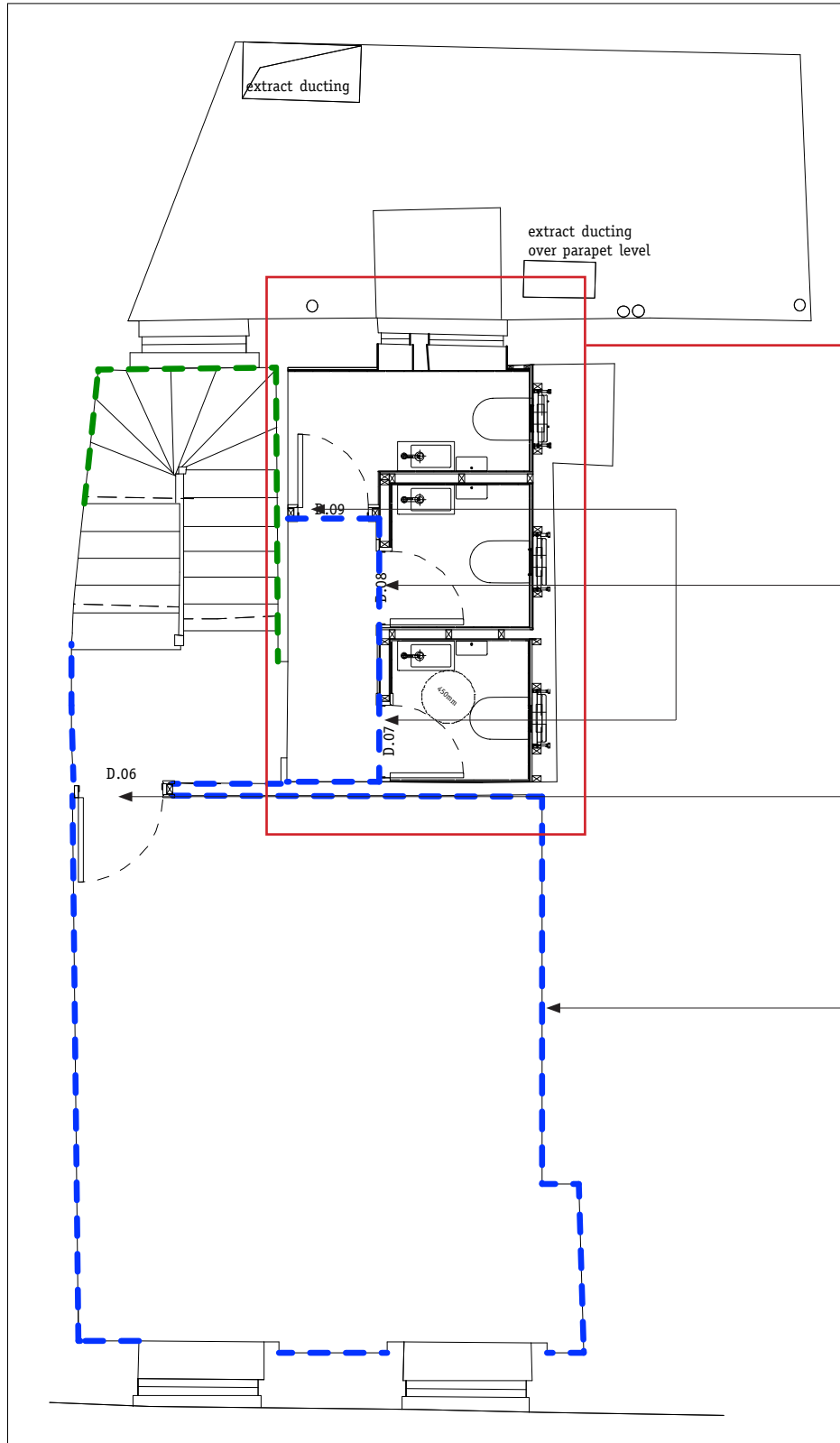

Note these will be read as modern partitions hence modern doors to be used as traditional type will be inappropriate in a modern partition.

Refer to typical WC door, p16.

Existing modern door to be retained.

Replaces existing modern skirting.

LEGEND

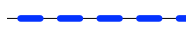
 To receive traditional skirting detail. Refer to page 18 for typical skirting detail.

 Existing traditional skirting retained.

Gundry

+

Ducker

THIRD FLOOR

FLOORING



Existing: Original floor boards fixed to joists to be retained and repaired.



Proposed: The existing floorboards to receive floating ply overlaid on existing boards, ply to receive a vinyl flooring. original floorboard presented underneath.



CEILING

NO WORKS- DECORATE ONLY

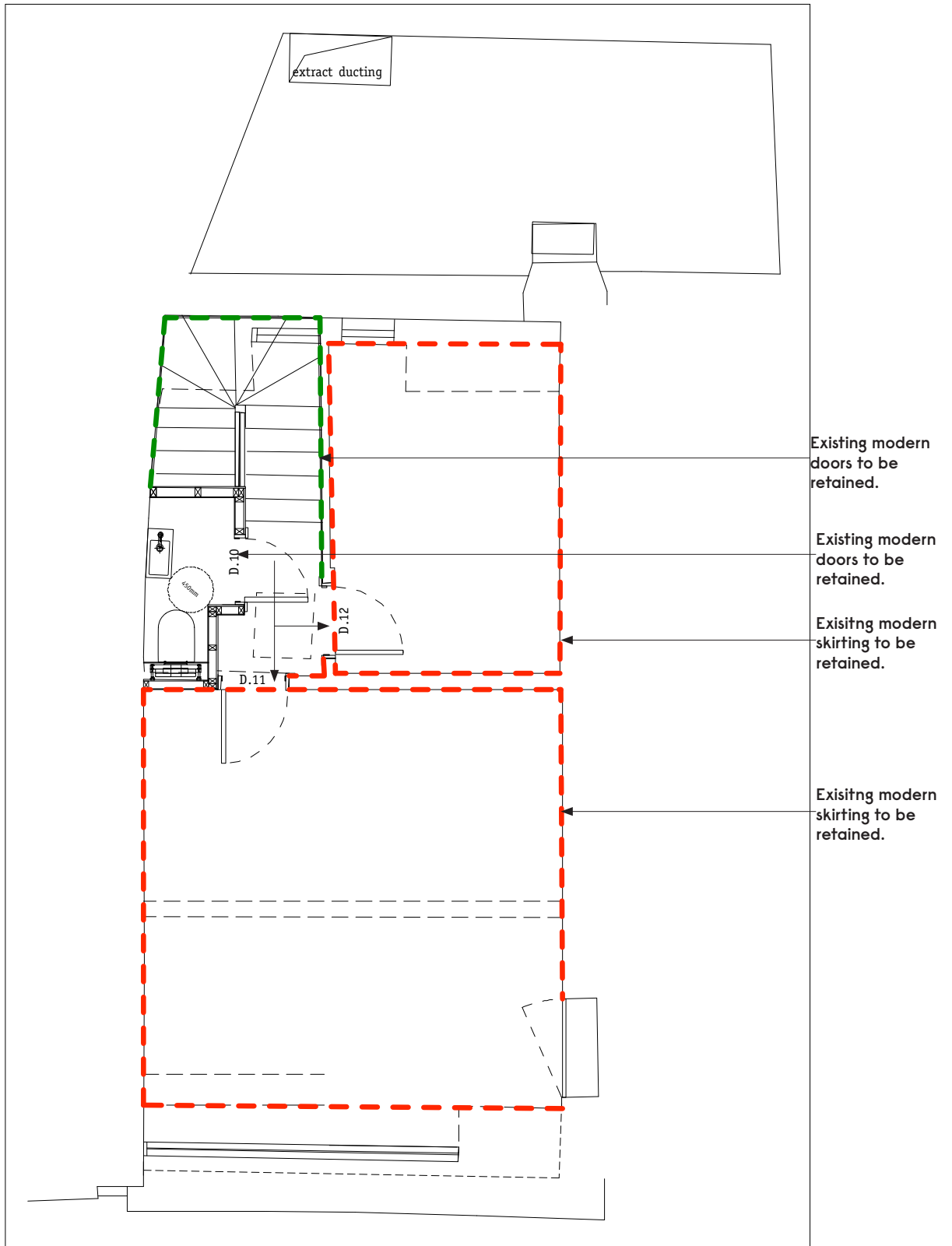
THIRD FLOOR PLAN

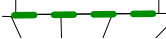

LEGEND

-  Existing traditional skirting retained.
-  Existing modern skirting retained.

STAIR JOINERY DETAILS

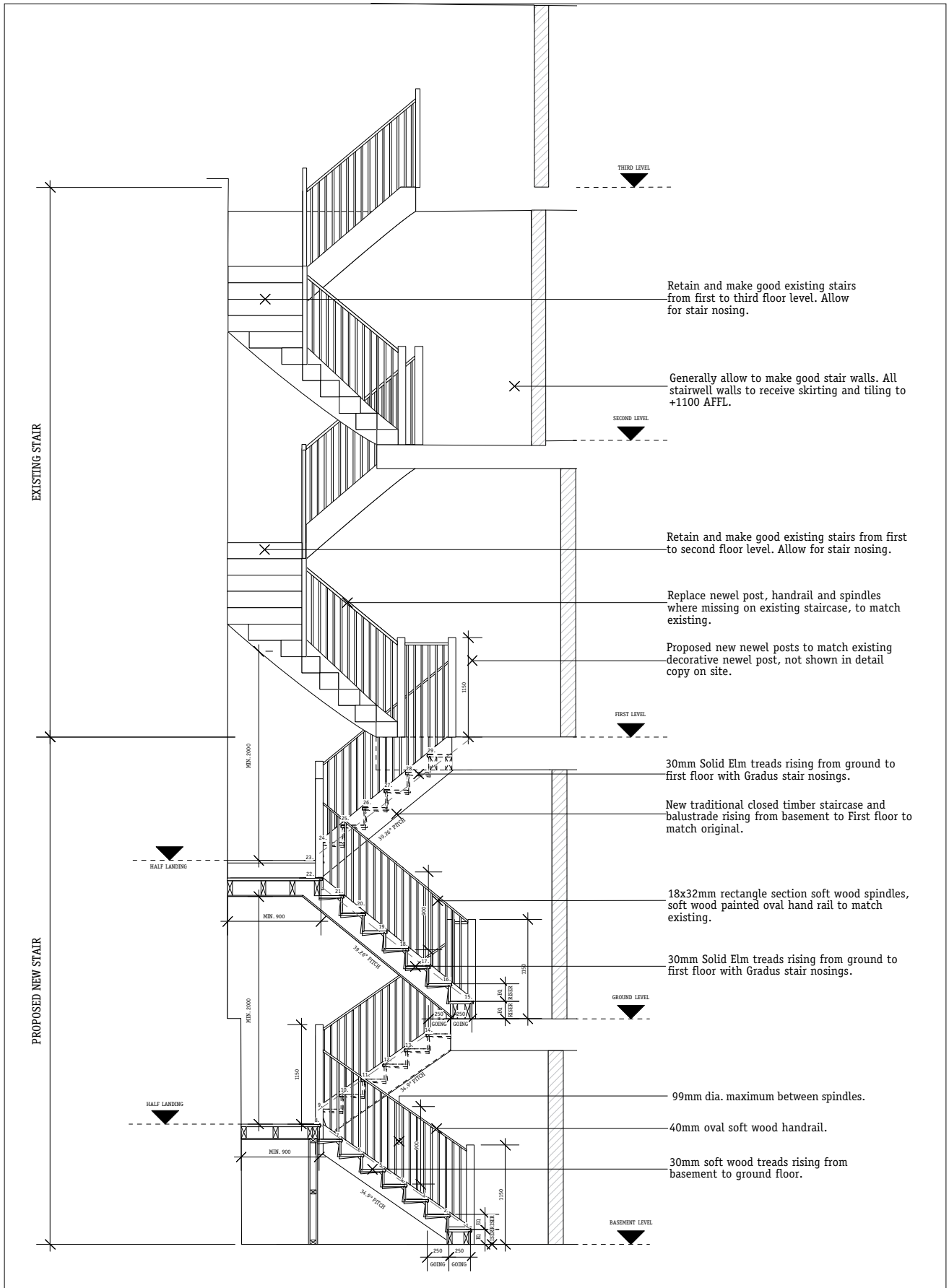

STAIR JOINERY DETAILS



Existing spindles and handrail.



Existing stairs.

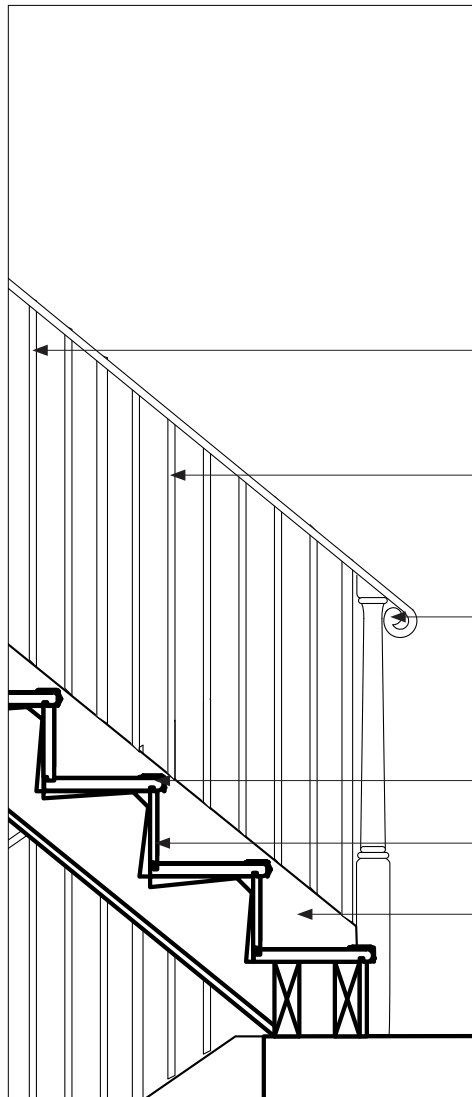

18x32mm rectangle section soft wood. spindles at centres to match existing.

Oval hand rail to match existing.

Decorative end to hand rail to match existing.

Bullnose timber tread to match existing.

Timber riser no bead to top.

Closed stringer.

Gundry

Detail of typical traditional panelled door.

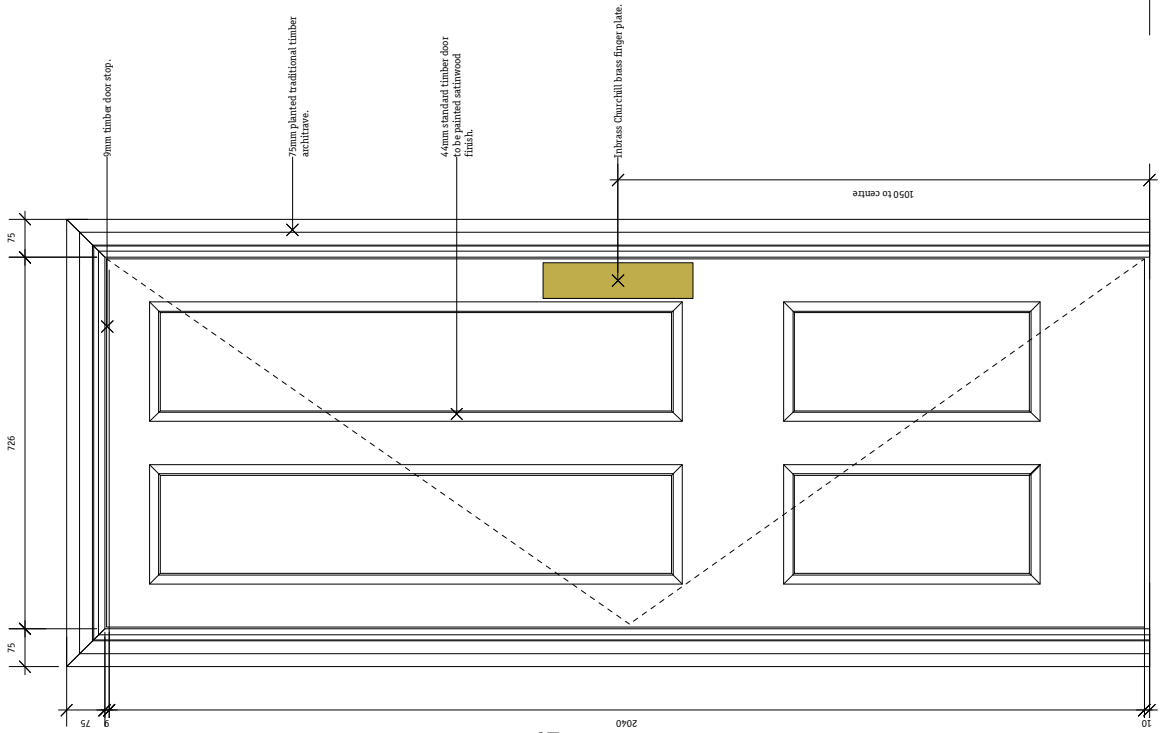

1 Typical panelled door Front Elevation
1:5@A3

+

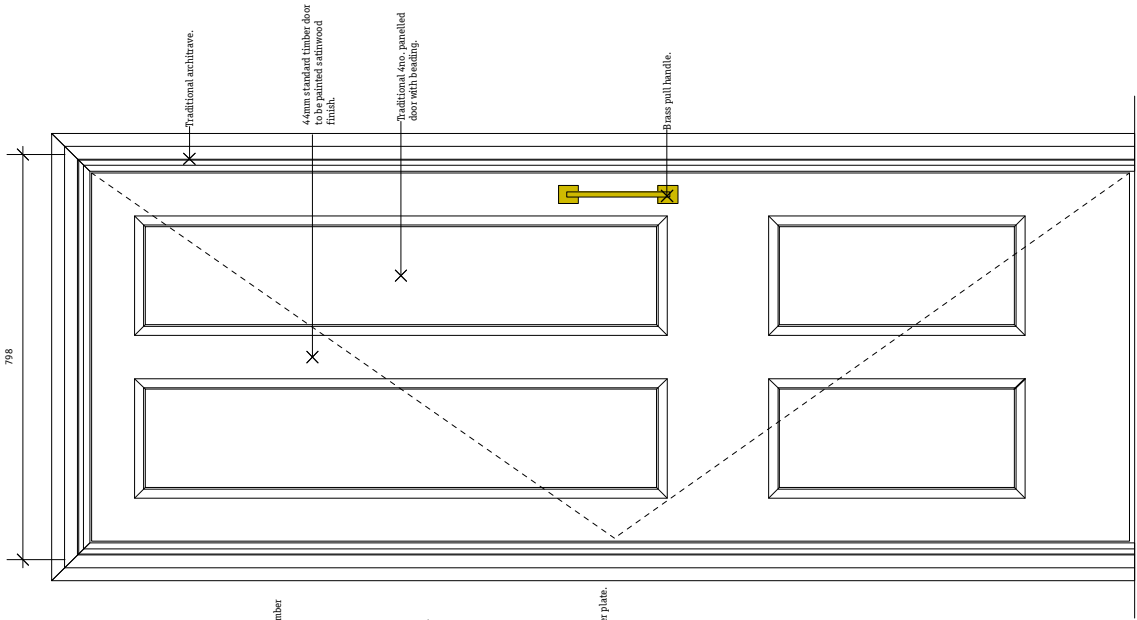

2 Typical Panelled door Rear Elevation
1:5@A3

Ducker

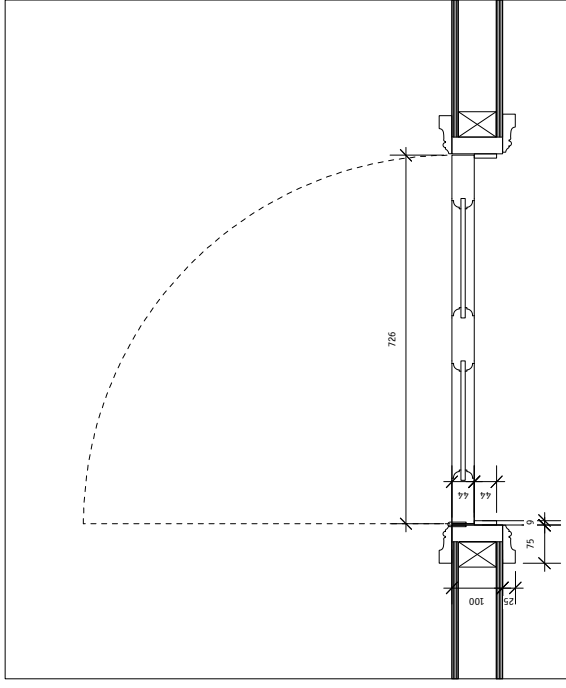

3 Typical Panelled door plan section
1:5@A3

Gundry

+

Ducker

Detail of typical door to WC's. D.Ø7, D.Ø8, D.Ø9 & D.10

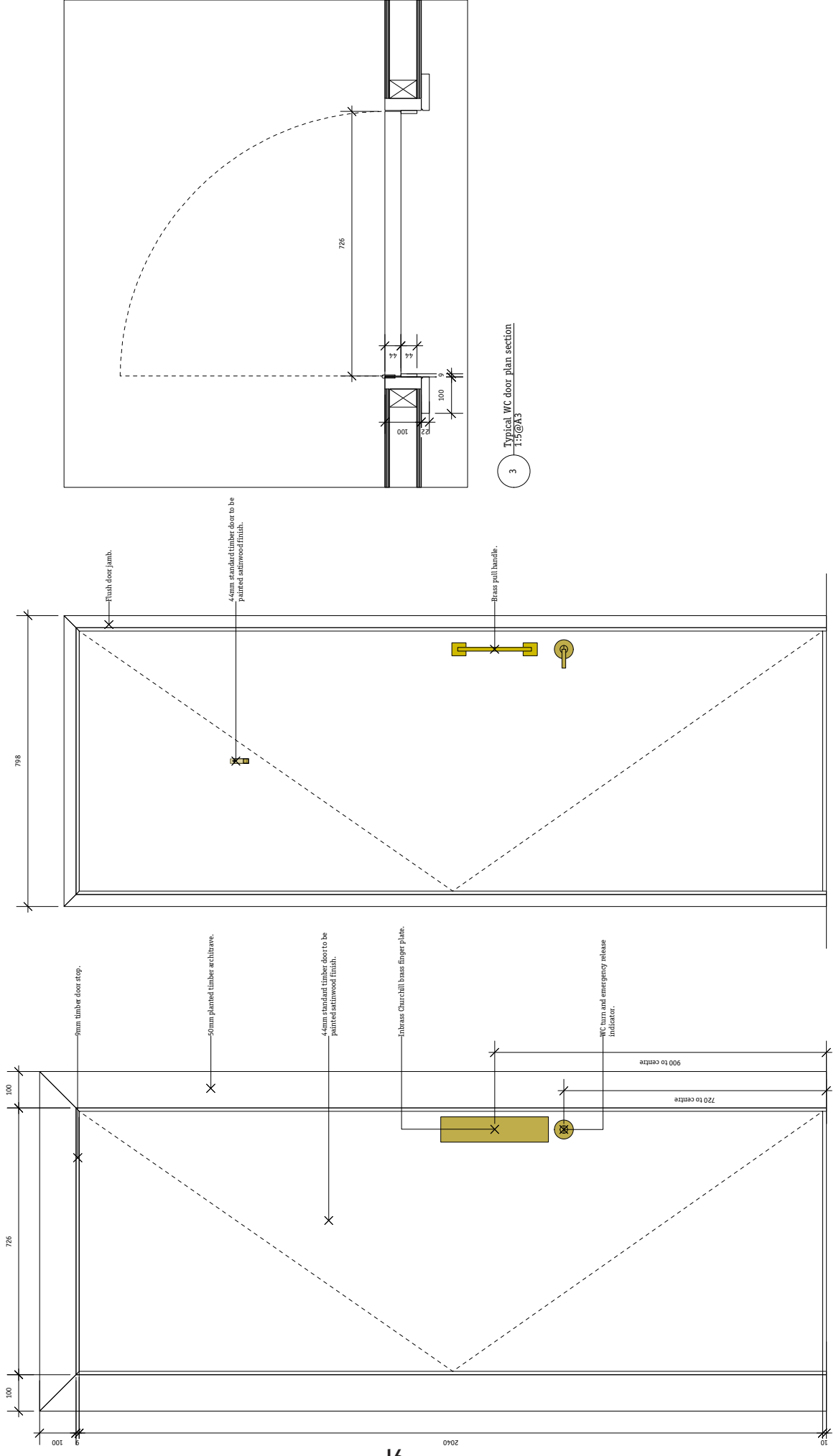

Typical plasterboard wall detail (partitions)

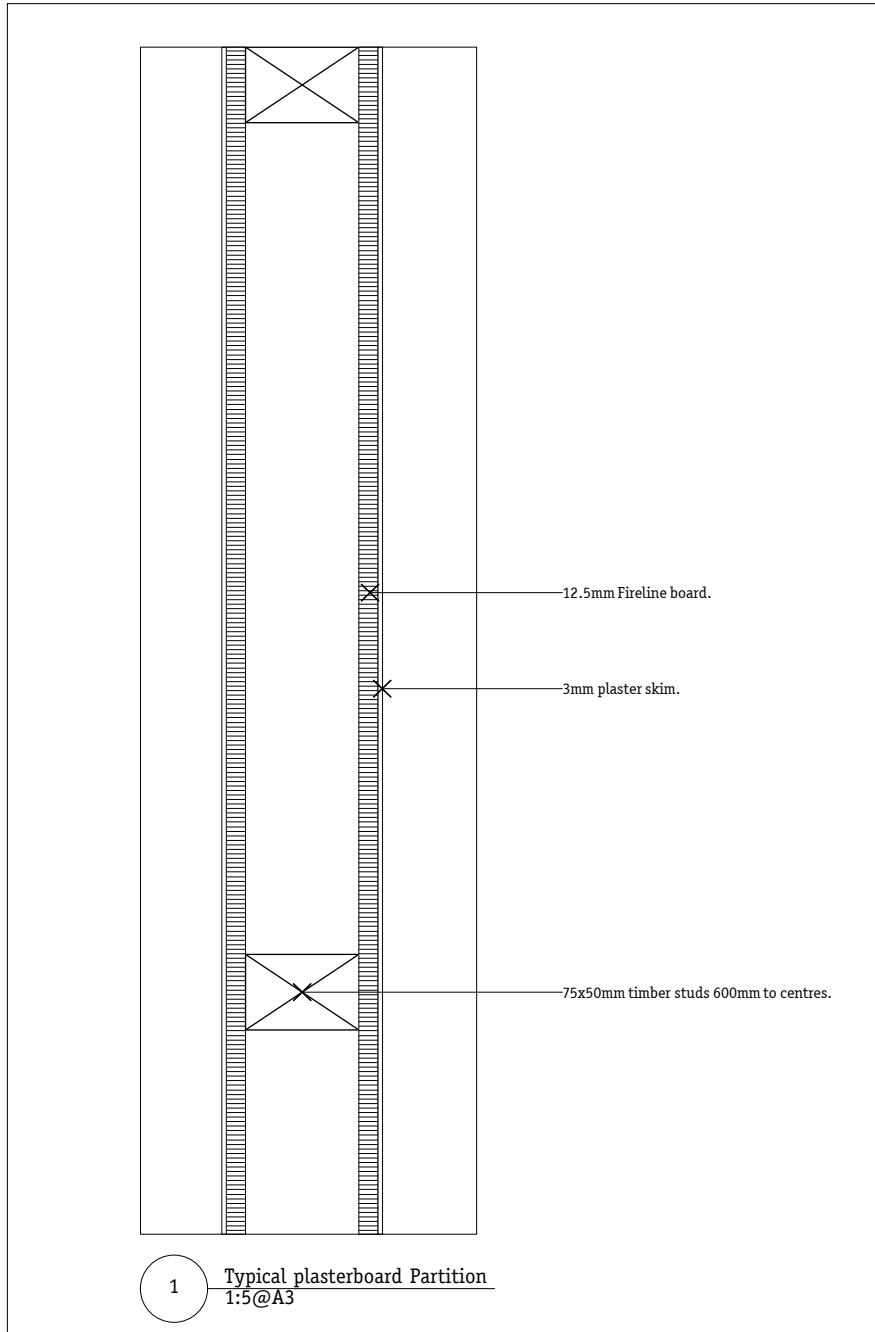

Detail of Typical Traditional Skirting

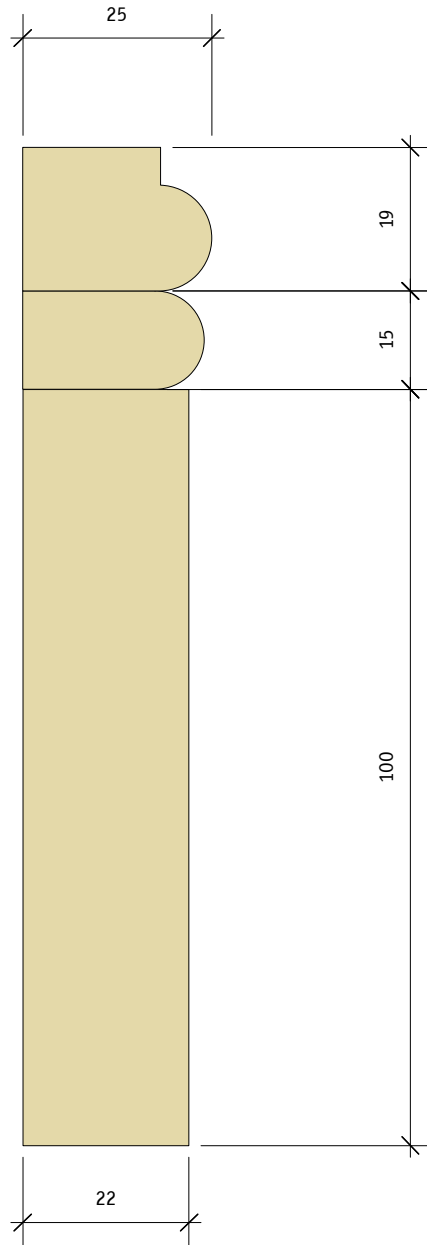

1 Traditional skirting detail
1:1

WINDOWS

All windows are to be retained and decorated.

FIRST FLOOR



Windows to front facade



Windows to rear



Light well window to rear of first floor.

SECOND FLOOR



Window to rear on stairs.



Windows to front facade, shutters restored.

THIRD FLOOR



Windows to rear on stairs.



Windows to rear.



Windows to facade.