

01 Jamb detail as extg

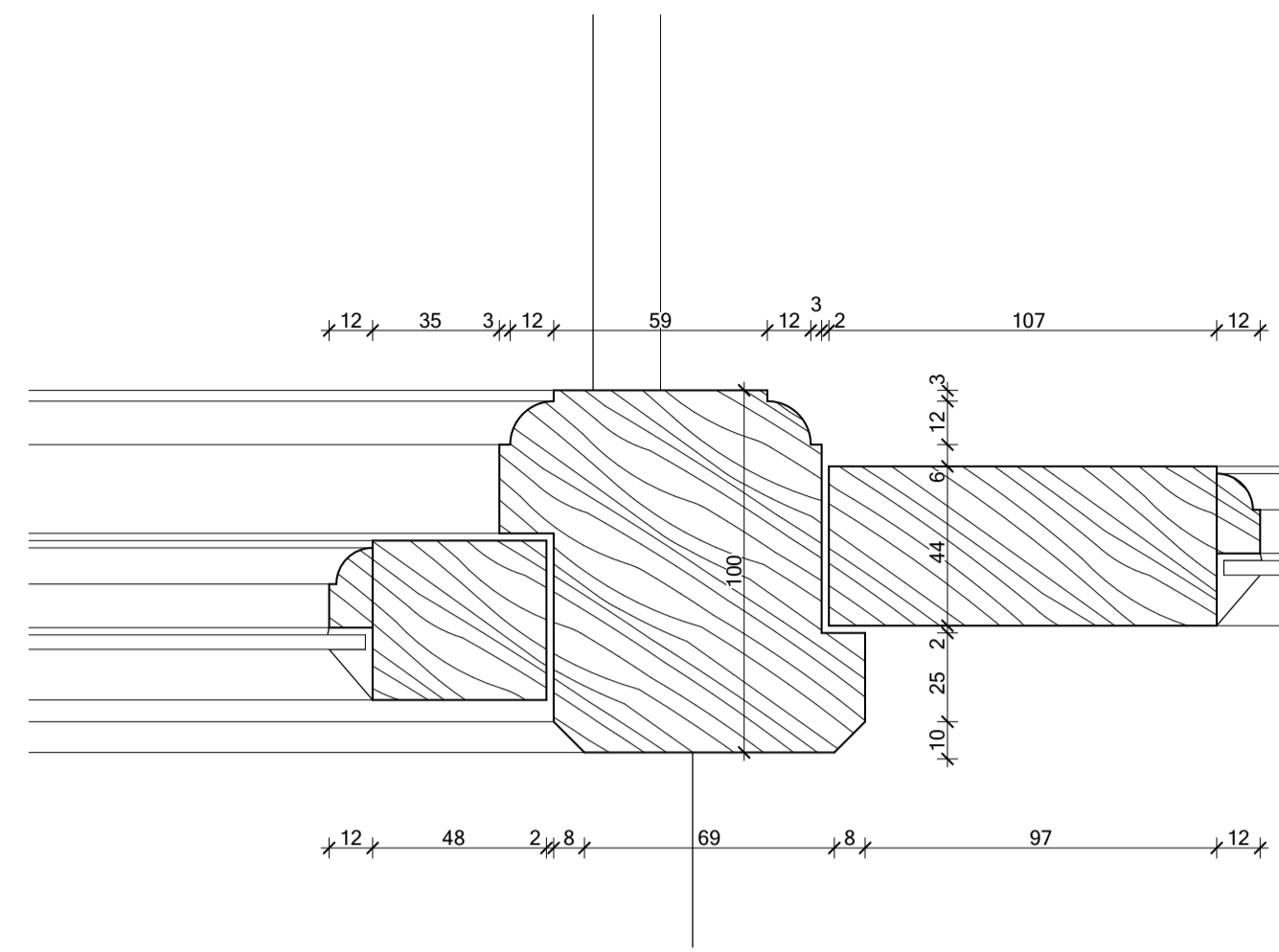

02 Mullion detail as extg

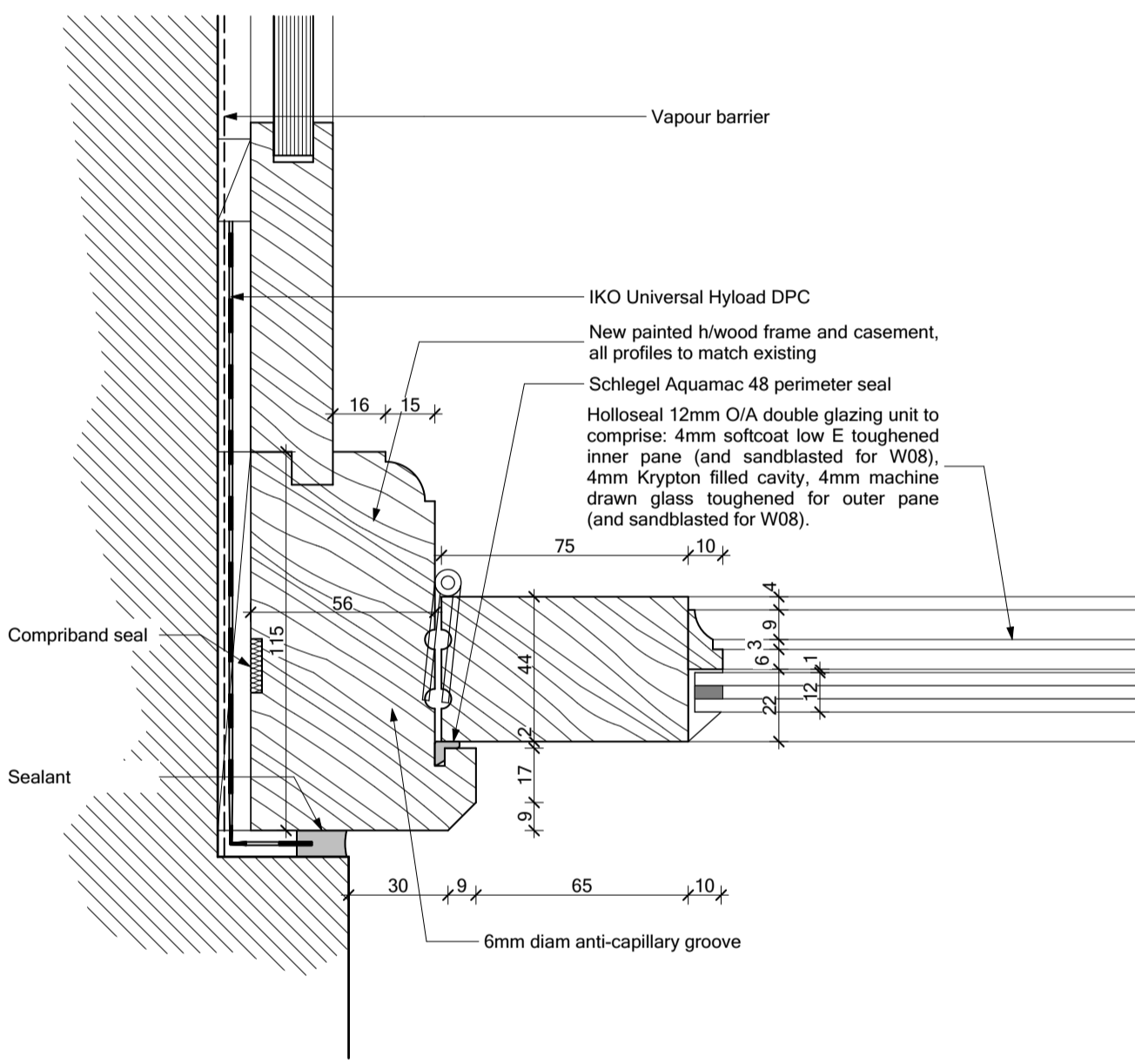

03 Jamb detail as proposed

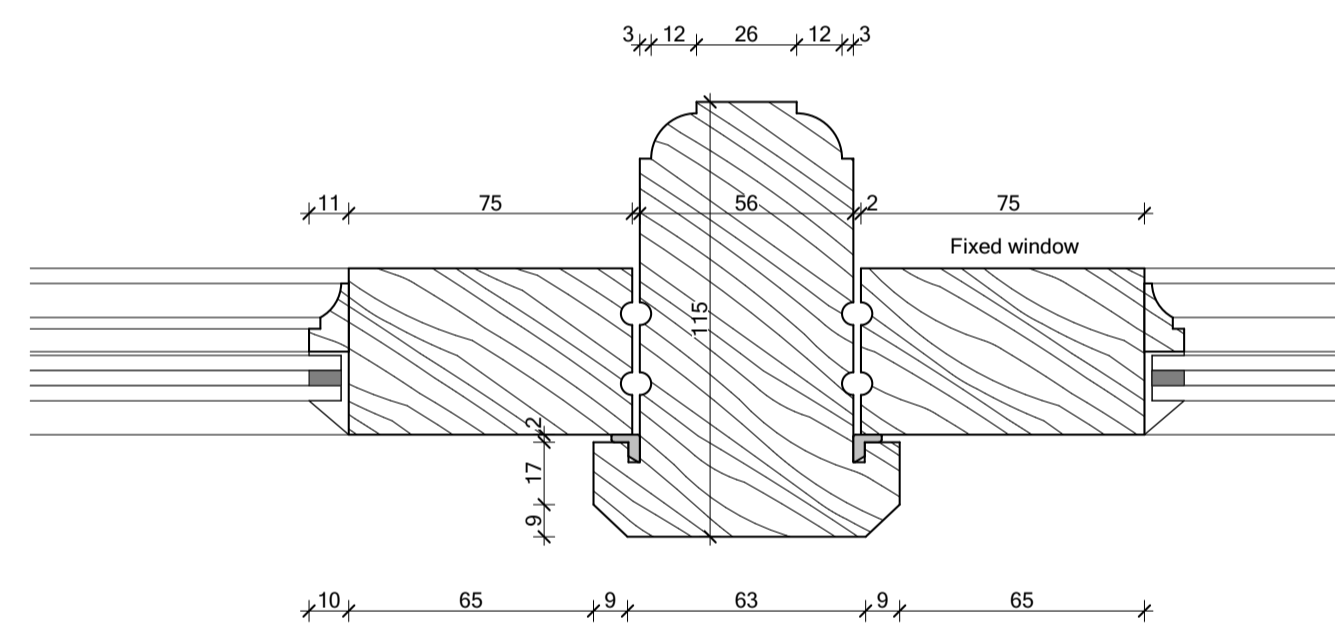

04 Mullion detail as proposed

Adjacent Properties and Boundaries are shown for illustrative purposes only and have not been surveyed unless otherwise stated.  
 All areas shown are approximate and should be verified before forming the basis of a decision.  
 Do not scale other than for Planning Application purposes.  
 All dimensions must be checked by the contractor before commencing work on site.  
 No deviation from this drawing will be permitted without the prior written consent of the Architect.  
 The copyright of this drawing remains with the Architect and may not be reproduced in any form without prior written consent.  
 Ground Floor Slabs, Foundations, Sub-Structures, etc. All work below ground level is shown provisionally. Inspection of ground condition is essential prior to work commencing.  
 Reassessment is essential when the ground conditions are apparent, and redesign may be necessary in the light of soil conditions found. The responsibility for establishing the soil and sub-soil conditions rests with the contractor.

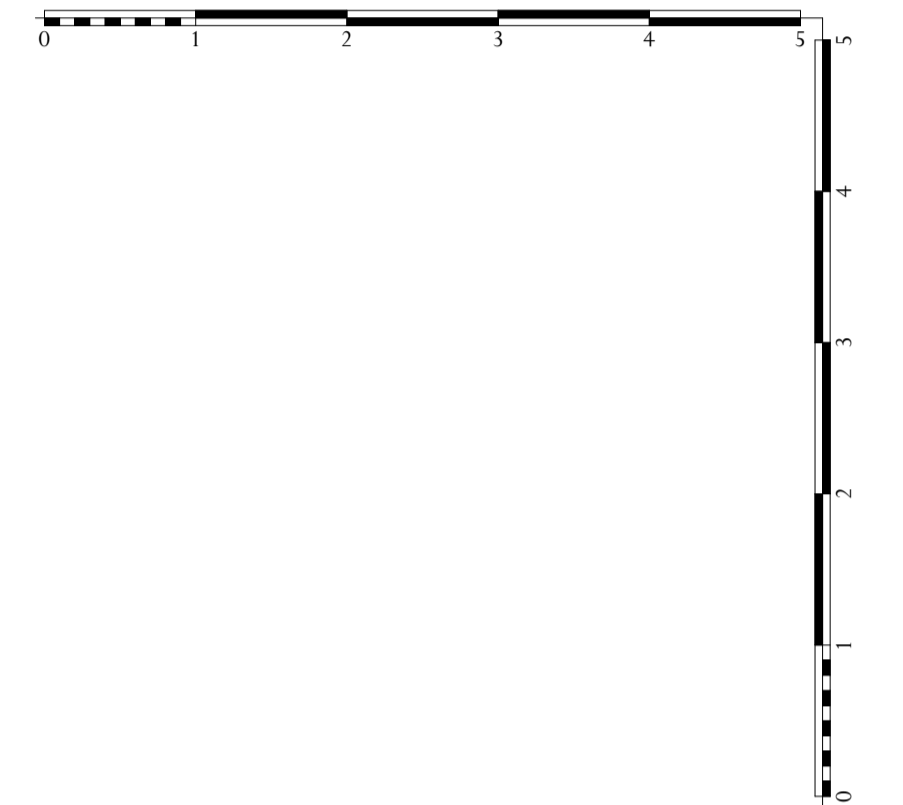

PLANNING			
A	11.04.17	Glazing pattern revised. D18 shown opening inwards.	RM
Rev.	Date	Description	Initials

PROJECT Flat 1 Russell Square Mansions  
 Refurbishment and alterations

TITLE: Door to terrace - Details

SCALE: 1:2 @ A1

DATE: February 2017

DRAWING No: 5962/31 A

DRAWN BY: RM

**ADAM ARCHITECTURE**

6 QUEEN SQUARE, BLOOMSBURY, LONDON, WC1N 3AT  
 TELEPHONE: 020 7841 0140 FACSIMILE: 01962 843303  
 www.adamarchitecture.com london@adamarchitecture.com